

Turning tool system of outer circle

	MVVNR	DVVNR	EVVNR	SVVBN	SVVCN
	MDPNN	DDPNN	EDPNN	SDNCN	
	MTENN	WTENN	ETENN	STECR	
	MCMNN-80	DCMNN-80	ECMNN-80	SCMCN-80	MWENN
	MSDNN	DSDNN	ESDNN	SSDCN	SSSCR
	MSSNR	DSSNR	ESSNR	MCSNR	DCSNR
	MCMNN-100	DCMNN-100	ECMNN-100	SCMCN-100	

	MWWNR	MWWNR-B	JSDN3CR
	MTWNR	MTWNR-B	STWCR

	CH-SDUCL	CH-STUCL	CH-SVUPL	
	MVUNR	DVUNR	SVUBR	SVUCR

	MCFNR	DCFNR	ECFNR	SCFCR	MDFNR
	SDFCR	MTFNR	DTFNR	ETFNR	STFCR

	DS-SCLL	DS-SDUL	DS-SDXL	DS-PTXL	DS-SVXL
--	----------------	----------------	----------------	----------------	----------------

	MCKNR	DCKNR	ECKNR	SCKCR
	MSKNR	DSKNR	ECKNR	SCKCR

	DS-SVVPN
--	-----------------

	CSV	TFT
--	------------	------------

	MCGNR	DCGNR	ECGNR	SCGCR	MTGNR	DTGNR	ETGNR	STGCR	JSTA2CR	MTJNR		
	WTJNR	DTJNR	ETJNR	MDJNR	DDJNR	EDJNR	SDACR	JSDJ2CR	SDJCR	SDJCR-F	SVJBR	SVJCR

	MVJNR	DVJNR	EVJNR	JSVJ2B/CR	SVLBR-F	SCACR	SCLCR	JSCL2CR	SCLNR	MCLNR	DCLNR
--	--------------	--------------	--------------	------------------	----------------	--------------	--------------	----------------	--------------	--------------	--------------

	ECLNR	MWLNR	DWLNR	WWLNR	EWLNR	STLNR	KTXNR	MTQNR	WTQNR	ETQNR
--	--------------	--------------	--------------	--------------	--------------	--------------	--------------	--------------	--------------	--------------

	MDQNR	DDQNR	EDQNR	SDQCR	MVQNR	DVQNR	EVQNR	SVQBR	SVQCR	SVPCR-F
--	--------------	--------------	--------------	--------------	--------------	--------------	--------------	--------------	--------------	----------------

	MCBNR	DCBNR	ECBNR
--	--------------	--------------	--------------

	SCBCR	MTBNR	WTBNR	MSBNR
--	--------------	--------------	--------------	--------------

	DSBNR	SSBCR	MSRNR	ESRNR
--	--------------	--------------	--------------	--------------

	SRAP(C)R	SRDP(C)N	SRGP(C)R
--	-----------------	-----------------	-----------------

	CSV	TBTR	CH-GTTL	DS-TBPL	DS-KTKFL	TBVCN
--	------------	-------------	----------------	----------------	-----------------	--------------

	SABSR	SABSSL	TBPR	TBPSL	KTKFR	KTKFSL
--	--------------	---------------	-------------	--------------	--------------	---------------

M | D | E | P Type Cylindrical Turning Tool

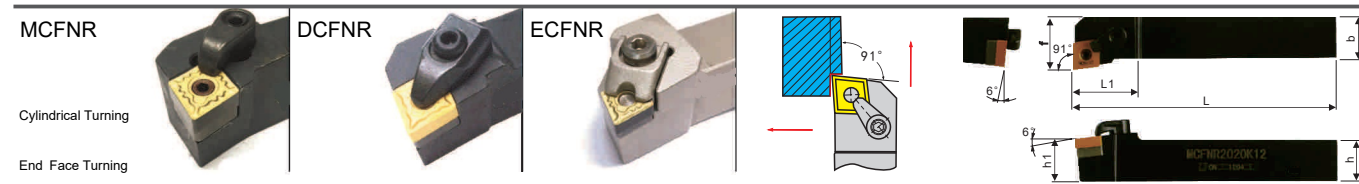

Ordering code	Dimensions						Insert	Pin	Shim	Wrench	Screw	Clamp	Stock	
	h	b	L	L1	h1	f							R	L
MCFNR/L 1616H12	16	16	100	32	16	20	CN..1204..	230007	230018	230047 230048	230063	230131	●	●
2020K12	20	20	125	32	20	25							●	●
2525M12	25	25	150	32	25	32							●	●
3232P12	32	32	170	32	32	40							○	○
2525M16	25	25	150	32	25	32	CN..1606..	230011	230019	230048 230049	230064	230134	○	○
3232P16	32	32	170	37	32	40							○	○
2525M19	25	25	150	32	25	32							○	○
3232P19	32	32	170	37	32	40							○	○
4040R19	40	40	200	38	40	50	CN..1906..	230012	230020	230049	230064	230134	○	○

Ordering code	Dimensions						Insert	Shim Screw	Shim	Wrench	Clamp Screw	Clamp	Stock	
	h	b	L	L1	h1	f							R	L
DCFNR/L 1616H12	16	16	100	32	16	20	CN..1204..	230014	230018	230048	230108	230136	○	○
2020K12	20	20	125	32	20	25							○	○
2525M12	25	25	150	32	25	32							○	○
3232P12	32	32	170	32	32	40							○	○

Ordering code	Dimensions						Insert	Pin	Shim	Wrench	Clamp Screw	Clamp	Stock	
	h	b	L	L1	h1	f							R	L
ECFNR/L 2020K12	20	20	125	32	20	25	CN..1204..	230015	230018	230048 230049	230112	230141	○	○
2525M12	25	25	150	32	25	32							○	○
3232P12	32	32	170	32	32	40							○	○

(R) R-Type

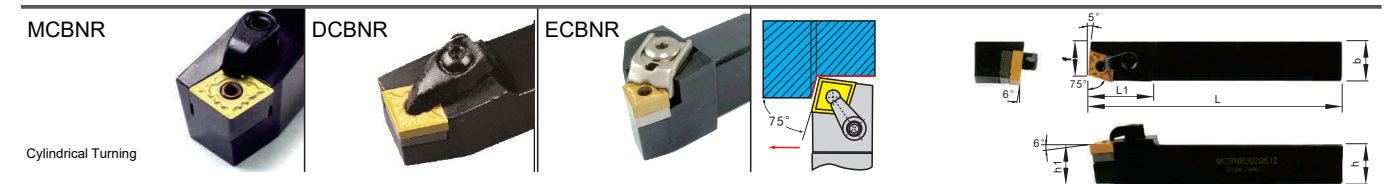

Ordering code	Dimensions						Insert	Pin	Shim	Wrench	Screw	Clamp	Stock	
	h	b	L	L1	h1	f							R	L
MCBNR/L 2020K12	20	20	125	32	20	17	CN..1204..	230007	230018	230047 230048	230063	230131	●	●
2525M12	25	25	150	32	25	22							●	●
3232P12	32	32	170	32	32	27							●	●
2525M16	25	25	150	37	25	22							○	○
3232P16	32	32	170	37	32	27	CN..1606..	230011	230019	230048 230049	230064	230134	○	○
4040R16	40	40	200	38	40	35							○	○
2525M19	25	25	150	32	25	22							○	○
3232P19	32	32	170	37	32	27							○	○
4040R19	40	40	200	38	40	35	CN..1906..	230012	230020	230049	230064	230134	○	○

Ordering code	Dimensions						Insert	Shim Screw	Shim	Wrench	Clamp Screw	Clamp	Stock	
	h	b	L	L1	h1	f							R	L
DCBNR/L 2020K12	20	20	125	32	20	17	CN..1204..	230014	230018	230048	230108	230136	○	○
2525M12	25	25	150	32	25	22							○	○
3232P12	32	32	170	32	32	27							○	○

Ordering code	Dimensions						Insert	Pin	Shim	Wrench	Clamp Screw	Clamp	Stock	
	h	b	L	L1	h1	f							R	L
ECBNR/L 2020K12	20	20	125	32	20	17	CN..1204..	230015	230018	230048 230049	230112	230143	○	○
2525M12	25	25	150	32	25	22							○	○
3232P12	32	32	170	32	32	27							○	○

R-Type

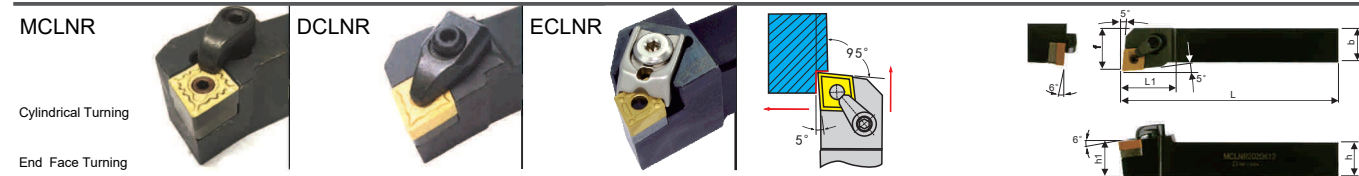

Ordering code	Dimensions						Insert	Pin	Shim	Wrench	Screw	Clamp	Stock	
	h	b	L	L1	h1	f							R	L
MCLNR/L 1616H12	16	16	100	32	16	20	CN..1204..	230007	230018	230047 230048	230063	230131	●	●
2020K12	20	20	125	32	20	25							●	●
2525M12	25	25	150	32	25	32							●	●
3232P12	32	32	170	32	32	40							○	○
2525M16	25	25	150	37	25	32	CN..1606..	230011	230019	230048 230049	230064	230134	○	○
3232P16	32	32	170	37	32	40							○	○
4040R16	40	40	200	38	40	50							○	○
2525M19	25	25	150	32	25	32							○	○
3232P19	32	32	170	37	32	40	CN..1906..	230012	230020	230049	230064	230134	○	○
4040R19	40	40	200	38	40	50							○	○

Ordering code	Dimensions						Insert	Shim Screw	Shim	Wrench	Clamp Screw	Clamp	Stock	
	h	b	L	L1	h1	f							R	L
DCLNR/L 1616H12	16	16	100	32	16	20	CN..1204..	230014	230018	230048	230108	230136	○	○
2020K12	20	20	125	32	20	25							○	○
2525M12	25	25	150	32	25	32							○	○
3232P12	32	32	170	32	32	40							○	○

Ordering code	Dimensions						Insert	Pin	Shim	Wrench	Clamp Screw	Clamp	Stock	
	h	b	L	L1	h1	f							R	L
ECLNR/L 2020K12	20	20	125	32	20	25	CN..1204..	230015	230018	230048 230049	230112	230141	○	○
2525M12	25	25	150	32	25	32							○	○
3232P12	32	32	170	32	32	40							○	○

(R) R-Type

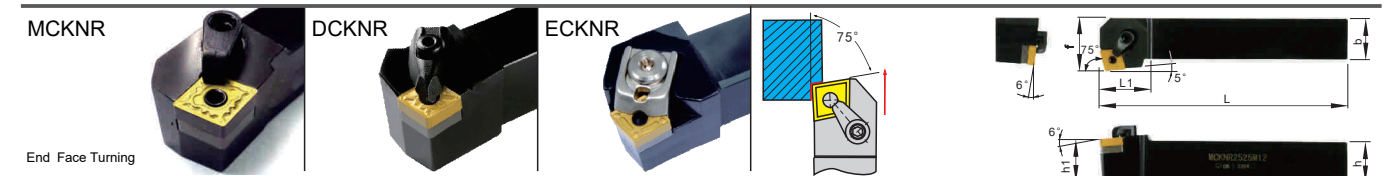

Ordering code	Dimensions						Insert	Pin	Shim	Wrench	Screw	Clamp	Stock	
	h	b	L	L1	h1	f							R	L
MCKNR/L 1616H12	16	16	100	32	16	20	CN..1204..	230007	230018	230047 230048	230063	230131	●	●
2020K12	20	20	125	32	20	25							●	●
2525M12	25	25	150	32	25	32							●	●
3232P12	32	32	170	32	32	40							○	○
2525M16	25	25	150	37	25	32	CN..1606..	230011	230019	230048 230049	230064	230134	○	○
3232P16	32	32	170	37	32	40							○	○
4040R16	40	40	200	38	40	50							○	○
2525M19	25	25	150	32	25	32							○	○
3232P19	32	32	170	37	32	40	CN..1906..	230012	230020	230049	230064	230134	○	○

Ordering code	Dimensions						Insert	Shim Screw	Shim	Wrench	Clamp Screw	Clamp	Stock	
	h	b	L	L1	h1	f							R	L
DCKNR/L 1616H12	16	16	100	31.5	16	20	CN..1204..	230014	230018	230048	230108	230136	○	○
2020K12	20	20	125	31.0	20	25							○	○
2525M12	25	25	150	31.0	25	32							○	○
3232P12	32	32	170	31.0	32	40							○	○

Ordering code	Dimensions						Insert	Pin	Shim	Wrench	Clamp Screw	Clamp	Stock	
	h	b	L	L1	h1	f							R	L
ECKNR/L 2020K12	20	20	125	32	20	25	CN..1204..	230015	230018	230048 230049	230112	230143	○	○
2525M12	25	25	150	32	25	32							○	○
3232P12	32	32	170	32	32	40							○	○

(R) R-Type

M | D | E | P Type Cylindrical Turning Tool

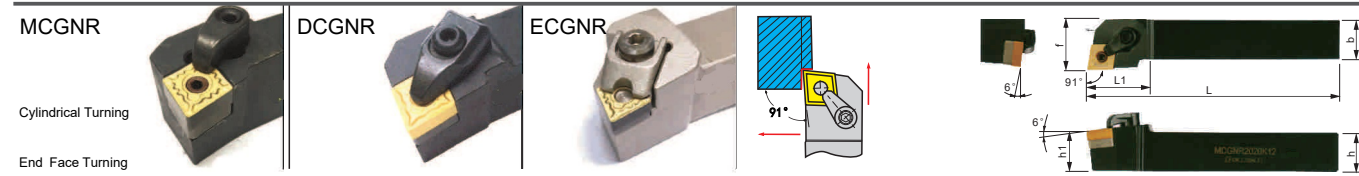

Ordering code	Dimensions						Insert	Pin	Shim	Wrench	Screw	Clamp	Stock	
	h	b	L	L1	h1	f							R	L
MCGNR/L 1616H12	16	16	100	32	16	20	CN..1204..	230007	230018	230047 230048	230063	230131	●	●
2020K12	20	20	125	32	20	25							●	●
2525M12	25	25	150	32	25	32							●	●
3232P12	32	32	170	32	32	40							●	●
2525M16	25	25	150	32	25	32	CN..1606..	230011	230019	230048 230049	230064	230134	●	●
3232P16	32	32	170	32	32	40							●	●

Ordering code	Dimensions						Insert	Shim Screw	Shim	Wrench	Clamp Screw	Clamp	Stock	
	h	b	L	L1	h1	f							R	L
DCGNR/L 1616H12	16	16	100	32	16	20	CN..1204..	230014	230018	230048	230108	230136	○	○
2020K12	20	20	125	32	20	25							○	○
2525M12	25	25	150	32	25	32							○	○
3232P12	32	32	170	32	32	40							○	○

Ordering code	Dimensions						Insert	Pin	Shim	Wrench	Clamp Screw	Clamp	Stock	
	h	b	L	L1	h1	f							R	L
ECGNR/L 2020K12	20	20	125	32	20	25	CN..1204..	230015	230018	230048 230049	230112	230141	○	○
2525M12	25	25	150	32	25	32							○	○
3232P12	32	32	170	32	32	40							○	○

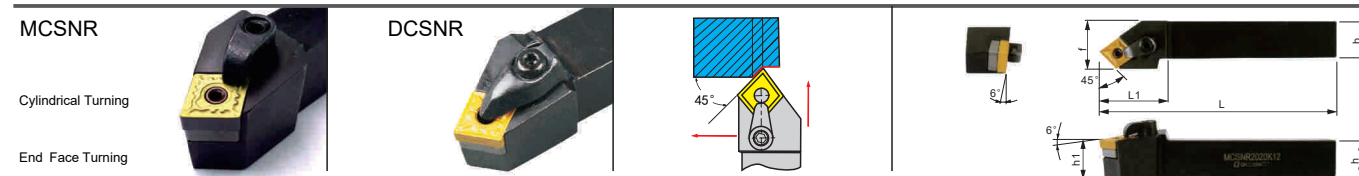

Ordering code	Dimensions						Insert	Pin	Shim	Wrench	Screw	Clamp	Stock	
	h	b	L	L1	h1	f							R	L
MCSNR/L 1616H12	16	16	100	32	16	20	CN..1204..	230007	230018	230047 230048	230063	230131	●	●
2020K12	20	20	125	35	20	25							●	●
2525M12	25	25	150	38	25	32							●	●
3232P12	32	32	170	38	32	40							●	●

Ordering code	Dimensions						Insert	Shim Screw	Shim	Wrench	Clamp Screw	Clamp	Stock	
	h	b	L	L1	h1	f							R	L
DCSNR/L 2020K12	20	20	125	35	20	25	CN..1204..	230014	230018	230048	230108	230136	○	○
2525M12	25	25	150	38	25	32							○	○
3232P12	32	32	170	38	32	40							○	○

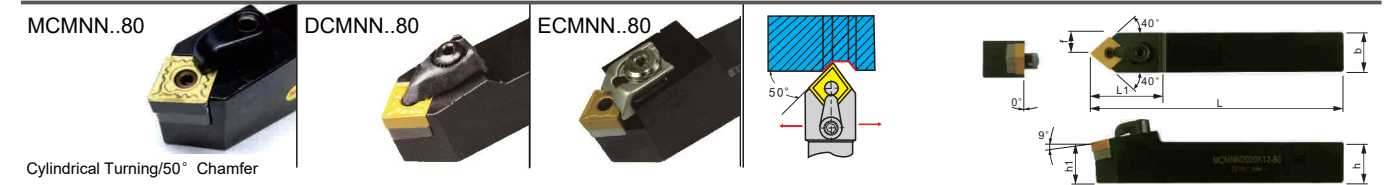

Ordering code	Dimensions						Insert	Pin	Shim	Wrench	Screw	Clamp	Stock	
	h	b	L	L1	h1	f							R	L
MCMNN 1616H12-80	16	16	100	35	16	8	CN..1204..	230007	230018	230047 230048	230063	230131	●	●
2020K12-80	20	20	125	35	20	10							●	●
2525M12-80	25	25	150	38	25	12.5							●	●
3232P12-80	32	32	170	38	32	16							●	●
2525M16-80	25	25	150	43	25	12.5	CN..1606..	230011	230019	230048 230049	230064	230134	●	●
3232P16-80	32	32	170	43	32	16							●	●
3232P19-80	32	32	170	45	32	16	CN..1906..	230012	230020	230049	230064		●	●

Ordering code	Dimensions						Insert	Shim Screw	Shim	Wrench	Clamp Screw	Clamp	Stock	
	h	b	L	L1	h1	f							R	L
DCMNN 1616H12-80	16	16	100	35	16	8	CN..1204..	230014	230018	230048	230108	230136	○	○
2020K12-80	20	20	125	35	20	10							○	○
2525M12-80	25	25	150	38	25	12.5							○	○
3232P12-80	32	32	170	38	32	16							○	○

Ordering code	Dimensions						Insert	Pin	Shim	Wrench	Clamp Screw	Clamp	Stock	
	h	b	L	L1	h1	f							R	L
ECMNN 2020K12-80	20	20	125	35	20	10	CN..1204..	230015	230018	230048 230049	230112	230141	○	○
2525M12-80	25	25	150	38	25	12.5							○	○
3232P12-80	32	32	170	38	32	16							○	○

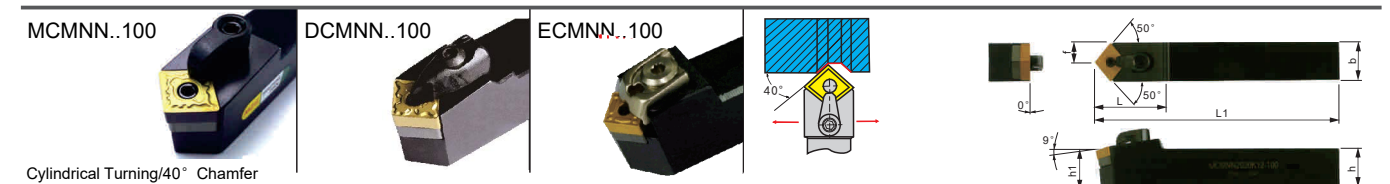

Ordering code	Dimensions						Insert	Pin	Shim	Wrench	Screw	Clamp	Stock	
	h	b	L	L1	h1	f							R	L
MCMNN 1616H12-100	16	16	100	35	16	8	CN..1204..	230007	230018	230047 230048	230063	230131	●	●
2020K12-100	20	20	125	35	20	10							●	●
2525M12-100	25	25	150	38	25	12.5							●	●
3232P12-100	32	32	170	38	32	16							●	●
2525M16-100	25	25	150	43	25	12.5	CN..1606..	230011	230019	230048 230049	230064	230134	●	●
3232P16-100	32	32	170	43	32	16							●	●
3232P19-100	32	32	170	45	32	16	CN..1906..	230012	230020	230049	230064		●	●

刀把型号 Ordering code	Dimensions						Insert	Shim Screw	Shim	Wrench	Clamp Screw	Clamp	Stock	
	h	b	L	L1	h1	f							R	L
DCMNN 1616H12-100	16	16	100	35	16	8	CN..1204..	230014	230018	230048	230108	230136	○	○
2020K12-100	20	20	125	35	20	10							○	○
2525M12-100	25	25	150	38	25	12.5							○	○
3232P12-100	32	32	170	38	32	16							○	○

Ordering code	Dimensions						Insert	Pin	Shim	Wrench	Clamp Screw	Clamp	Stock	
	h	b	L	L1	h1	f							R	L
ECMNN 2020K12-100	20	20	125	35	20	10	CN..1204..	230015	230018	230048 230049	230112	230143	○	○
2525M12-100	25	25	150	38	25	12.5							○	○
3232P12-100	32	32	170	38	32	16							○	○

M | D | E | P Type Cylindrical Turning Tool

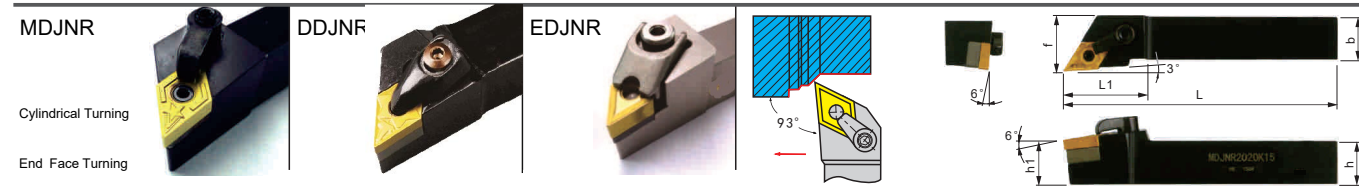

Ordering code	Dimensions						Insert	Pin	Shim	Wrench	Screw	Clamp	Stock	
	h	b	L	L1	h1	f							R	L
MDJNR/L 1616H11	16	16	100	31.5	16	20	DN..1104..	230007	230021	230152 230051	230063	230131	●	●
2020K11	20	20	125	33	20	25							●	●
2525M11	25	25	150	33	25	32							●	●
1616H15	32	32	170	31.5	32	20	DN..1504.. DN..1506..	230010	230023 230022	230050 230051	230063	230133	●	●
2020K15	25	25	150	39	25	25							●	●
2525M15	32	32	170	40	32	32							●	●
3232P15	32	32	170	42	32	40	●	●					●	●

Ordering code	Dimensions						Insert	Shim Screw	Shim	Wrench	Clamp Screw	Clamp	Stock	
	h	b	L	L1	h1	f							R	L
DDJNR/L 1616H11	16	16	100	31.5	16	20	DN..1104..	230013	230021	230048	230108	230138	○	○
2020K11	20	20	125	33	20	25							○	○
2525M11	25	25	150	33	25	32							○	○
2020K15	20	20	125	39	20	25	DN..1504.. DN..1506..	230014	230022 230023	230048	230108	230137	●	○
2525M15	25	25	150	40	25	32							●	○
3232P15	32	32	170	42	32	40							○	○

Ordering code	Dimensions						Insert	Pin	Shim	Wrench	Clamp Screw	Clamp	Stock	
	h	b	L	L1	h1	f							R	L
EDJNR/L 2020K15	20	20	125	39	20	25	DN..1504..	230015	230022	230048 230049	230112	230142	○	○
2525M15	25	25	150	40	25	32							○	○
3232P15	32	32	170	42	32	40							○	○

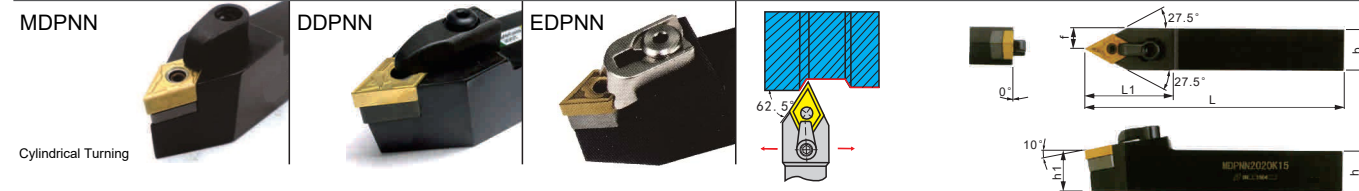

Ordering code	Dimensions						Insert	Pin	Shim	Wrench	Screw	Clamp	Stock	
	h	b	L	L1	h1	f							R	L
MDPNN 1616H11	16	16	100	36	16	8	DN..1104..	230007	230021	230046 230048	230063	230131	●	●
2020K11	20	20	125	36	20	10							●	●
2525M11	25	25	150	36	25	12.5							●	●
1616H15	32	32	100	43	32	8	DN..1504.. DN..1506..	230010	230023 230022	230047 230048	230063	230133	●	●
2020K15	25	25	125	43	25	10							●	●
2525M15	32	32	150	43	32	12.5							●	●
3232P15	32	32	170	43	32	16	●	●					●	●

Ordering code	Dimensions						Insert	Shim Screw	Shim	Wrench	Clamp Screw	Clamp	Stock	
	h	b	L	L1	h1	f							R	L
DDPNN 1616H11	16	16	100	36	16	8	DN..1104..	230013	230021	230048	230108	230138	○	○
2020K11	20	20	125	36	20	10							○	○
2525M11	25	25	150	36	25	12.5							○	○
2020K15	20	20	125	43	20	10	DN..1504.. DN..1506..	230014	230022 230023	230048	230108	230137	●	○
2525M15	25	25	150	43	25	12.5							●	○
3232P15	32	32	170	43	32	16							○	○

Ordering code	Dimensions						Insert	Pin	Shim	Wrench	Clamp Screw	Clamp	Stock	
	h	b	L	L1	h1	f							R	L
EDPNN 2020K15	20	20	125	39	20	10	DN..1504..	230015	230022	230048 230049	230112	230142	○	○
2525M15	25	25	150	40	25	12.5							○	○
3232P15	32	32	170	42	32	16							○	○

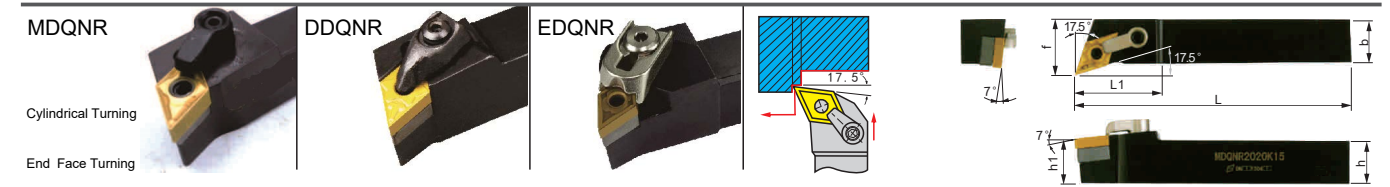

Ordering code	Dimensions						Insert	Pin	Shim	Wrench	Screw	Clamp	Stock	
	h	b	L	L1	h1	f							R	L
MDQNR/L 1616H11	16	16	100	31.5	16	20	DN..1104..	230007	230021	230046 230048	230063	230131	●	●
2020K11	20	20	125	33	20	25							●	●
2525M11	25	25	150	33	25	32							●	●
1616H15	16	16	100	31.5	16	20	DN..1504.. DN..1506..	230010	230023 230022	230047 230048	230063	230133	●	●
2020K15	20	20	125	39	20	25							●	●
2525M15	25	25	150	40	25	32							●	●
3232P15	32	32	170	42	32	40	●	●					●	●

Ordering code	Dimensions						Insert	Shim Screw	刀垫 Shim	Wrench	Clamp Screw	Clamp	Stock	
	h	b	L	L1	h1	f							R	L
DDQNR/L 1616H11	16	16	100	32	16	20	DN..1104..	230013	230021	230048	230108	230138	○	○
2020K11	20	20	125	32	20	25							○	○
2525M11	25	25	150	32	25	32							○	○
2020K15	20	20	125	37	20	25	DN..1504.. DN..1506..	230014	230022 230023	230048	230108	230137	●	○
2525M15	25	25	150	37	25	32							●	○
3232P15	32	32	170	37	32	40							○	○

Ordering code	Dimensions						Insert	Pin	Shim	Wrench	Clamp Screw	Clamp	Stock	
	h	b	L	L1	h1	f							R	L
EDQNR/L 2020K15	20	20	125	39	20	25	DN..1504..	230015	230022	230048 230049	230112	230142	○	○
2525M15	25	25	150	40	25	32							○	○
3232P15	32	32	170	42	32	40							○	○

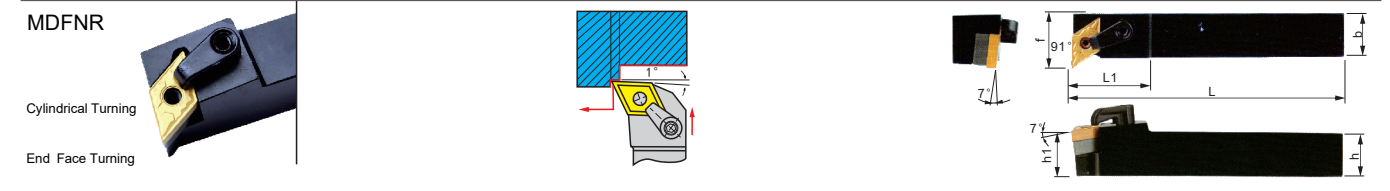

Ordering code	Dimensions						Insert	Pin	Shim	Wrench	Screw	Clamp	Stock	
	h	b	L	L1	h1	f							R	L
MDFNR/L 1616H11	16	16	100	31.5	16	20	DN..1104..	230007	230021	230046 230048	230063	230131	●	●
2020K11	20	20	125	33	20	25							●	●
2525M11	25	25	150	33	25	32							●	●
1616H15	16	16	170	31.5	16	20	DN..1504.. DN..1506..	230010	230023 230022	230047 230048	230063	230133	●	●
2020K15	20	20	150	39	20	25							●	●
2525M15	25	25	170	40	25	32							●	●
3232P15	32	32	170	42	32	40	●	●					●	●

Ordering code	Dimensions						Insert	Shim Screw	Shim	Wrench	Clamp Screw	Clamp	Stock	
	h	b	L	L1	h1	f							R	L
DDFNR/L 1616H11	16	16	100	32	16	20	DN..1104..	230013	230021	230048	230108	230138	○	○
2020K11	20	20	125	32	20	25							○	○
2525M11	25	25	150	32	25	32							○	○
2020K15	20	20	125	37	20	25	DN..1504.. DN..1506..	230014	230022 230023	230048	230108	230137	●	○
2525M15	25	25	150	37	25	32							●	○
3232P15	32	32	170	37	32	40							○	○

M | D | E | P Type Cylindrical Turning Tool

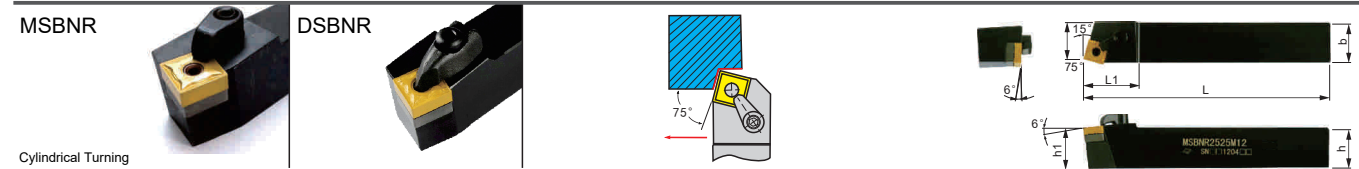

Ordering code	Dimensions						Insert	Pin	Shim	Wrench	Screw	Clamp	Stock	
	h	b	L	L1	h1	f							R	L
MSBNR/L 1616H12	16	16	100	32	16	13	SN..1204..	230007	230024	230047 230048	230063	230131	●	●
2020K12	20	20	125	32	20	17							○	○
2525M12	25	25	150	32	25	22							○	○
3232P12	32	32	170	32	32	27							○	○
2525M15	25	25	150	32	25	22							○	○
3232P15	32	32	170	37	32	27	○	○						
3232P19	32	32	170	37	32	27	○	○						
4040R19	40	40	200	40	40	35	○	○						

Ordering code	Dimensions						Insert	Shim Screw	Shim	Wrench	Clamp Screw	Clamp	Stock	
	h	b	L	L1	h1	f							R	L
DSBNR/L 2020K12	20	20	125	32.5	20	17	SN..1204..	230014	230024	230048	230108	230136	○	○
2525M12	25	25	150	32.5	25	22							○	○
3232P12	32	32	170	32.5	32	27							○	○

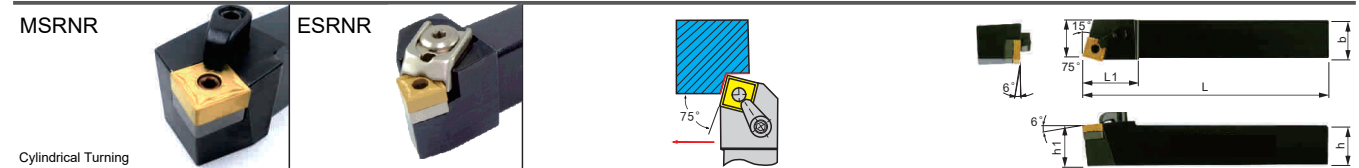

Ordering code	Dimensions						Insert	Pin	Shim	Wrench	Screw	Clamp	Stock	
	h	b	L	L1	h1	f							R	L
MSRNR/L 1616H12	16	16	100	35	16	20	SN..1204..	230007	230024	230047 230048	230063	230131	●	●
2020K12	20	20	125	35	20	25							○	○
2525M12	25	25	150	35	25	32							○	○
3232P12	32	32	170	35	32	40							○	○
2525M15	25	25	150	40	25	32							○	○
3232P15	32	32	170	40	32	40	○	○						
3232P19	32	32	170	40	32	40	○	○						
4040R19	40	40	200	40	40	50	○	○						

Ordering code	Dimensions						Insert	Shim Screw	Shim	Wrench	Clamp Screw	Clamp	Stock	
	h	b	L	L1	h1	f							R	L
DSRNR/L 2020K12	20	20	125	32.5	20	25	SN..1204..	230014	230024	230048	230108	230136	○	○
2525M12	25	25	150	32.5	25	32							○	○
3232P12	32	32	170	32.5	32	40							○	○

Ordering code	Dimensions						Insert	Pin	Shim	Wrench	Clamp Screw	Clamp	Stock	
	h	b	L	L1	h1	f							R	L
ESRNR/L 2020K16	20	20	125	35	20	25	SN..1204..	230015	230024	230047 230049	230112	230144	○	○
2525M16	25	25	150	37	25	32							○	○
3232P16	32	32	170	37	32	40							○	○

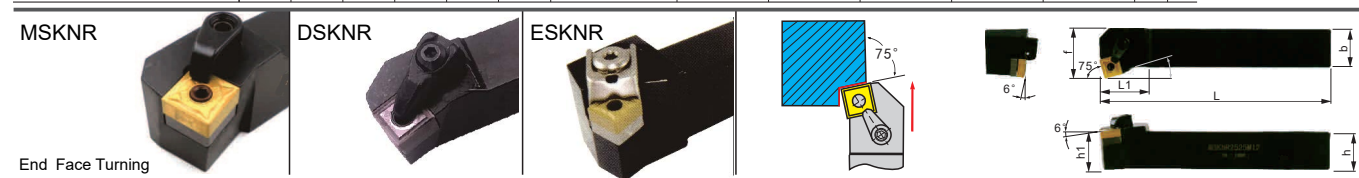

Ordering code	Dimensions						Insert	Pin	Shim	Wrench	Screw	Clamp	Stock	
	h	b	L	L1	h1	f							R	L
MSKNR/L 1616H12	16	16	100	35	16	20	SN..1204..	230007	230024	230047 230048	230063	230131	●	●
2020K12	20	20	125	35	20	25							○	○
2525M12	25	25	150	35	25	32							○	○
3232P12	32	32	170	35	32	40							○	○
2525M15	25	25	150	40	25	32							○	○
3232P15	32	32	170	40	32	40	○	○						
3232P19	32	32	170	40	32	40	○	○						
4040R19	40	40	200	40	40	50	○	○						

Ordering code	Dimensions						Insert	Shim Screw	Shim	Wrench	Clamp Screw	Clamp	Stock	
	h	b	L	L1	h1	f							R	L
DSKNR/L 2020K12	20	20	125	31	20	25	SN..1204..	230014	230024	230048	230108	230136	○	○
2525M12	25	25	150	28	25	32							○	○
3232P12	32	32	170	28	32	40							○	○

Ordering code	Dimensions						Insert	Pin	Shim	Wrench	Clamp Screw	Clamp	Stock	
	h	b	L	L1	h1	f							R	L
ESKNR/L 2020K16	20	20	125	35	20	25	SN..1204..	230015	230024	230047 230049	230112	230144	○	○
2525M16	25	25	150	37	25	32							○	○
3232P16	32	32	170	37	32	40							○	○

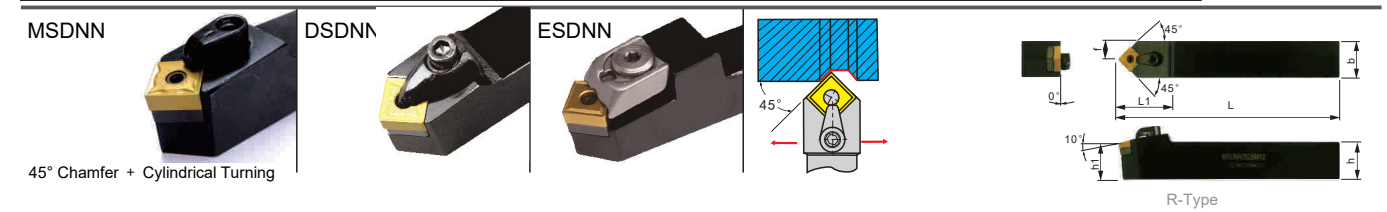

Ordering code	Dimensions						Insert	Pin	Shim	Wrench	Screw	Clamp	Stock	
	h	b	L	L1	h1	f							R	L
MSDNN 1616H12	16	16	100	35	16	8	SN..1204..	230007	230024	230047 230048	230063	230131	●	●
2020K12	20	20	125	35	20	10							○	○
2525M12	25	25	150	35	25	12.5							○	○
3232P12	32	32	170	35	32	16							○	○
2525M15	25	25	150	40	25	12.5							○	○
3232P15	32	32	170	40	32	16	○	○						
3232P19	32	32	170	40	32	16	○	○						
4040R19	40	40	200	40	40	20	○	○						

Ordering code	Dimensions						Insert	Shim Screw	Shim	Wrench	Clamp Screw	Clamp	Stock	
	h	b	L	L1	h1	f							R	L
DSDNN 1616H12	16	16	100	35	16	8	SN..1204..	230014	230024	230048	230108	230136	○	○
2020K12	20	20	125	35	20	10							○	○
2525M12	25	25	150	37	25	12.5							○	○
3232P12	32	32	170	37	32	16							○	○

Ordering code	Dimensions						Insert	Pin	Shim	Wrench	Clamp Screw	Clamp	Stock	
	h	b	L	L1	h1	f							R	L
ESDNN 2020K16	20	20	125	35	20	10	SN..1204..	230015	230024	230047 230049	230112	230144	○	○
2525M16	25	25	150	37	25	12.5							○	○
3232P16	32	32	170	37	32	16							○	○

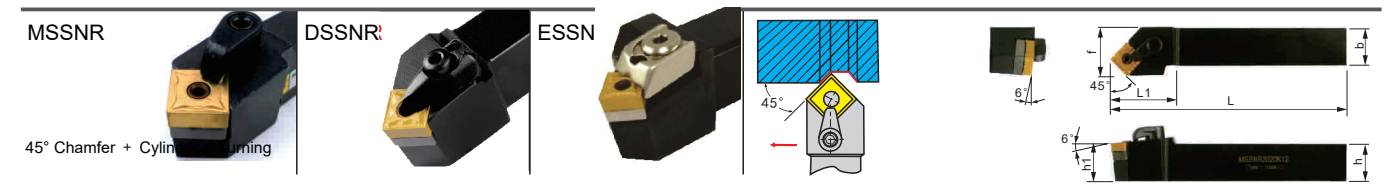

Ordering code	Dimensions						Insert	Pin	Shim	Wrench	Screw	Clamp	Stock	
	h	b	L	L1	h1	f							R	L
MSSNR/L 1616H12	16	16	100	35	16	20	SN..1204..	230007	230024	230047 230048	230063	230131	●	●
2020K12	20	20	125	35	20	25							○	○
2525M12	25	25	150	35	25	32							○	○
3232P12	32	32	170	35	32	40							○	○
2525M15	25	25	150	40	25	32							○	○
3232P15	32	32	170	40	32	40	○	○						
3232P19	32	32	170	40	32	40	○	○						
4040R19	40	40	200	40	40	50	○	○						

Ordering code	Dimensions						Insert	Shim Screw	Shim	Wrench	Clamp Screw	Clamp	Stock	
	h	b	L	L1	h1	f							R	L
DSSNR/L 1616H12	16	16	100	35	16	20	SN..1204..	230014	230024	230048	230108	230136	○	○
2020K12	20	20	125	35	20	25							○	○
2525M12	25	25	150	37	25	32							○	○
3232P12	32	32	170	37	32	40							○	○

Ordering code	Dimensions						Insert	Pin	Shim	Wrench	Clamp Screw	Clamp	Stock	
	h	b	L	L1	h1	f							R	L
ESSNR/L 2020K16	20	20	125	35	20	25	SN..1204..	230015	230024	230047 230049	230112	230144	○	○
2525M16	25	25	150	37	25	32							○	○
3232P16	32	32	170	37	32	40							○	○

M | D | E | P Type Cylindrical Turning Tool

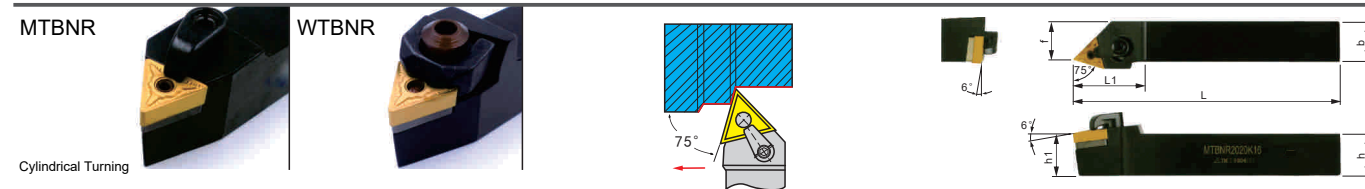

Ordering code	Dimensions						Insert	Pin	Shim	Wrench	Screw	Clamp	Stock	
	h	b	L	L1	h1	f							R	L
MTBNR/L 1616H16	16	16	100	28	16	15.5	TN..1604..	230003	230027	230046 230048	230063	230131	●	●
2020K16	20	20	125	28	20	15.5							●	●
2525M16	25	25	150	30	25	20.5							●	●
3232P16	32	32	170	33	32	27.5							○	○

Ordering code	Dimensions						Insert	Pin	Shim	Wrench	Screw	Clamp	Stock	
	h	b	L	L1	h1	f							R	L
WTBNR/L 1616H16	16	16	100	31.5	16	15.5	TN..0604..	230004	230027	230047 230049	230104	230148	●	●
2020K16	20	20	125	33	20	15.5							●	●
2525M16	25	25	150	33	25	20.5							●	●
3232P16	32	32	170	33	32	27.5							●	●

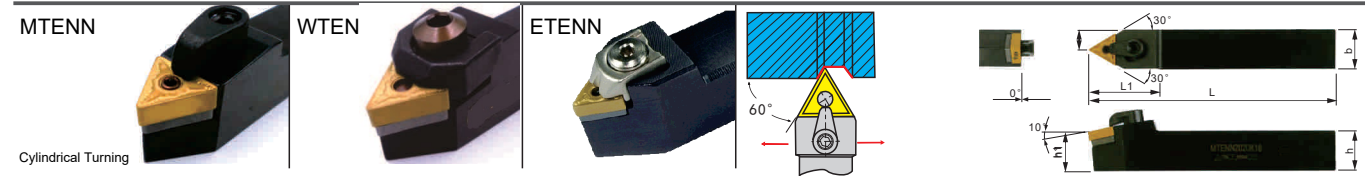

Ordering code	Dimensions						Insert	Pin	Shim	Wrench	Screw	Clamp	Stock	
	h	b	L	L1	h1	f							R	L
MTENN 1616H16	16	16	100	30	16	8	TN..1604..	230003	230027	230046 230048	230063	230131	●	●
2020K16	20	20	125	28	20	10							●	●
2525M16	25	25	150	30	25	12.5							●	●
3232P16	32	32	170	30	32	16							●	●
2525M22	25	25	150	36	25	12.5								
3232P22	32	32	170	36	32	16	TN..2204..	230007	230028	230047 230049	230064	230132	○	○

Ordering code	Dimensions						Insert	Pin	Shim	Wrench	Screw	Clamp	Stock	
	h	b	L	L1	h1	f							R	L
WTENN 2020K16	20	20	125	36	20	10	TN..1604..	230004	230027	230047 230049	230104	230148	●	●
2525M16	25	25	150	36	25	12.5							●	●
3232P16	32	32	170	36	32	16							●	●

Ordering code	Dimensions						Insert	Pin	Shim	Wrench	Clamp Screw	Clamp	Stock	
	h	b	L	L1	h1	f							R	L
ETENN 2020K16	20	20	125	36	20	10	TN..1604..	230005	230027	230047 230049	230112	230145	●	●
2525M16	25	25	150	36	25	12.5							●	●
3232P16	32	32	170	36	32	16							●	●

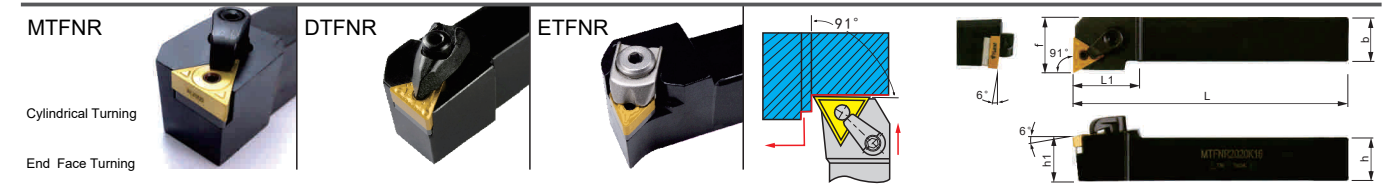

Ordering code	Dimensions						Insert	Pin	Shim	Wrench	Screw	Clamp	Stock	
	h	b	L	L1	h1	f							R	L
MTFNR/L 1616H16	16	16	100	30	16	20	TN..1604..	230003	230027	230046 230048	230063	230131	●	●
2020K16	20	20	125	28	20	25							●	●
2525M16	25	25	150	30	25	32							●	●
3232P16	32	32	170	30	32	40							●	●
2525M22	25	25	150	36	25	32	TN..2204..	230007	230028	230047 230049	230064	230132	○	○
3232P22	32	32	170	36	32	40							○	○

Ordering code	Dimensions						Insert	Shim Screw	Shim	Wrench	Clamp Screw	Clamp	Stock	
	h	b	L	L1	h1	f							R	L
DTFNR/L 1616H16	16	16	100	29	16	20	TN..1604..	230013	230027	230048	230108	230138	○	○
2020K16	20	20	125	29	20	25							○	○
2525M16	25	25	150	31	25	32							○	○
3232P16	32	32	170	31	32	40							○	○

Ordering code	Dimensions						Insert	Pin	Shim	Wrench	Clamp Screw	Clamp	Stock	
	h	b	L	L1	h1	f							R	L
ETFNR/L 2020K16	20	20	125	32	20	25	TN..1604..	230005	230027	230047 230049	230112	230145	○	○
2525M16	25	25	150	34	25	32							○	○
3232P16	32	32	170	34	32	40							○	○

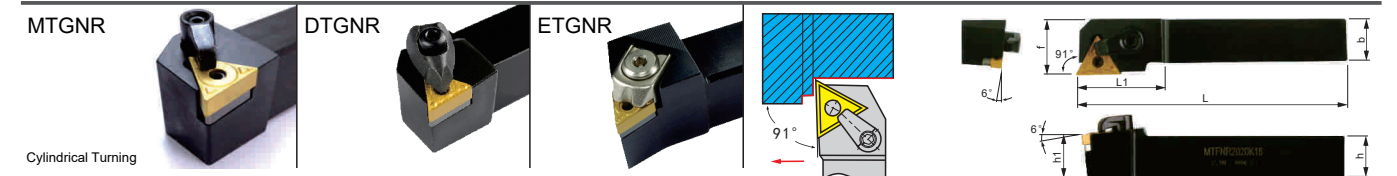

Ordering code	Dimensions						Insert	Pin	Shim	Wrench	Screw	Clamp	Stock	
	h	b	L	L1	h1	f							R	L
MTGNR/L 1616H16	16	16	100	30	16	20	TN..1604..	230003	230027	230046 230048	230063	230131	●	●
2020K16	20	20	125	28	20	25							●	●
2525M16	25	25	150	30	25	32							●	●
3232P16	32	32	170	30	32	40							●	●
2525M22	25	25	150	36	25	32								
3232P22	32	32	170	36	32	40	TN..2204..	230007	230028	230047 230049	230064	230132	○	○

Ordering code	Dimensions						Insert	Shim Screw	Shim	Wrench	Clamp Screw	Clamp	Stock	
	h	b	L	L1	h1	f							R	L
DTGNR/L 1616H16	16	16	100	29	16	20	TN..1604..	230013	230027	230048	230108	230138	○	○
2020K16	20	20	125	29	20	25							○	○
2525M16	25	25	150	31	25	32							○	○
3232P22	32	32	170	32	32	40							TN..2204..	230014

Ordering code	Dimensions						Insert	Pin	Shim	Wrench	Clamp Screw	Clamp	Stock	
	h	b	L	L1	h1	f							R	L
ETGNR/L 2020K16	20	20	125	32	20	25	TN..1604..	230005	230027	230047 230049	230112	230145	○	○
2525M16	25	25	150	34	25	32							○	○
3232P16	32	32	170	34	32	40							○	○

M | D | E | P Type Cylindrical Turning Tool

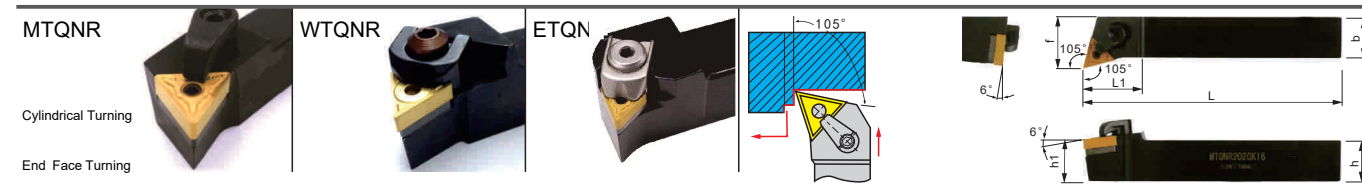

Ordering code	Dimensions						Insert	Pin	Shim	Wrench	Screw	Clamp	Stock	
	h	b	L	L1	h1	f							R	L
MTQNR/L 1616H16	16	16	100	30	16	20	TN..1604..	230003	230027	230046 230048	230063	230131	●	●
2020K16	20	20	125	28	20	25							●	●
2525M16	25	25	150	30	25	32							●	●
3232P16	32	32	170	30	32	40							●	●
2525M22	25	25	150	36	25	32	TN..2204..	230007	230028	230047 230049	230064	230132	○	○
3232P22	32	32	170	36	32	40							○	○

Ordering code	Dimensions						Insert	Pin	Shim	Wrench	Screw	Clamp	Stock	
	h	b	L	L1	h1	f							R	L
WTQNR/L 2020K16	20	20	125	32	20	25	TN..1604..	230004	230027	230047 230049	230104	230148	●	●
2525M16	25	25	150	32	25	32							●	●
3232P16	32	32	170	32	32	40							●	●

Ordering code	Dimensions						Insert	Pin	Shim	Wrench	Clamp Screw	Clamp	Stock	
	h	b	L	L1	h1	f							R	L
ETQNR/L 2020K16	20	20	125	32	20	25	TN..1604..	230005	230027	230047 230049	230112	230145	○	○
2525M16	25	25	150	34	25	32							○	○
3232P16	32	32	170	34	32	40							○	○

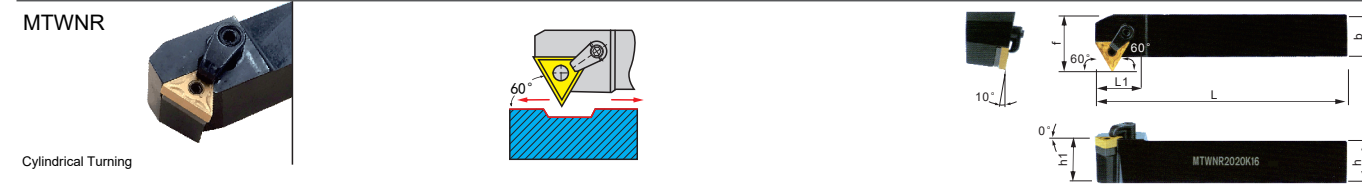

Ordering code	Dimensions						Insert	Pin	Shim	Wrench	Screw	Clamp	Stock	
	h	b	L	L1	h1	f							R	L
MTWNR/L 1616H16	16	16	100	30	16	20	TN..1604..	230003	230027	230046 230048	230063	230131	●	●
2020K16	20	20	125	30	20	25							●	●
2525M16	25	25	150	30	25	32							●	●

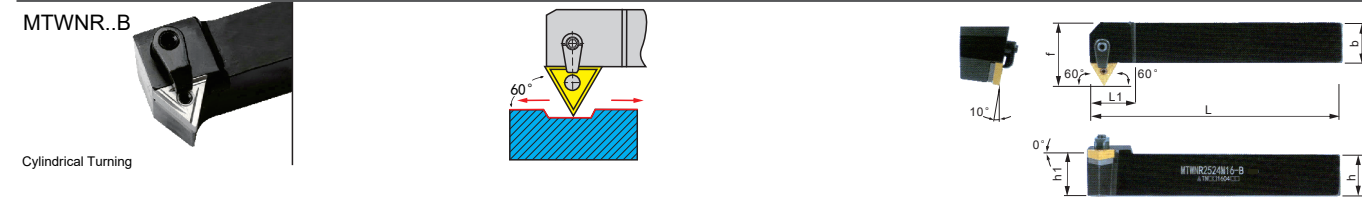

Ordering code	Dimensions						Insert	Pin	Shim	Wrench	Screw	Clamp	Stock	
	h	b	L	L1	h1	f							R	L
MTWNR/L 2020K16-B	20	20	125	26	20	33.5	TN..1604..	230003	230027	230046 230048	230063	230131	●	●
2524M16-B	25	24	150	26	25	37.5							●	●

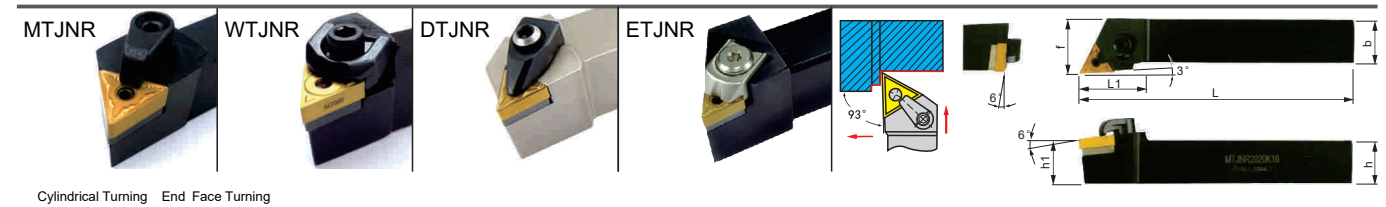

Ordering code	Dimensions						Insert	Pin	Shim	Wrench	Screw	Clamp	Stock	
	h	b	L	L1	h1	f							R	L
MTJNR/L 1616H16	16	16	100	30	16	20	TN..1604..	230003	230027	230046 230048	230063	230131	●	●
2020K16	20	20	125	28	20	25							●	●
2525M16	25	25	150	30	25	32							●	●
3232P16	32	32	170	30	32	40							●	●
2525M22	25	25	150	36	25	32							TN..2204..	230007
3232P22	32	32	170	36	32	40							○	○
4040R22	40	40	200	40	40	50							○	○

Ordering code	Dimensions						Insert	Shim Screw	Shim	Wrench	Clamp Screw	Clamp	Stock	
	h	b	L	L1	h1	f							R	L
DTJNR/L 2020K16	20	20	125	30	20	25	TN..1604..	230004	230027	230047 230049	230104	230140	○	○
2525M16	25	25	150	30	25	32							○	○
3232P16	32	32	170	32	32	40							○	○

Ordering code	Dimensions						Insert	Pin	Shim	Wrench	Screw	Clamp	Stock	
	h	b	L	L1	h1	f							R	L
WTJNR/L 1616H16	16	16	100	32	16	22	TN..1604..	230004	230027	230047 230049	230104	230148	○	○
2020K16	20	20	125	32	20	25							○	○
2525M16	25	25	150	34	25	32							○	○
3232P16	32	32	170	34	32	40							○	○

Ordering code	Dimensions						Insert	Pin	Shim	Wrench	Clamp Screw	Clamp	Stock	
	h	b	L	L1	h1	f							R	L
ETJNR/L 1616H16	16	16	100	32	16	22	TN..1604..	230005	230027	230047 230049	230112	230145	○	○
2020K16	20	20	125	32	20	25							○	○
2525M16	25	25	150	34	25	32							○	○
3232P16	32	32	170	34	32	40							○	○

M | D | E | P Type Cylindrical Turning Tool

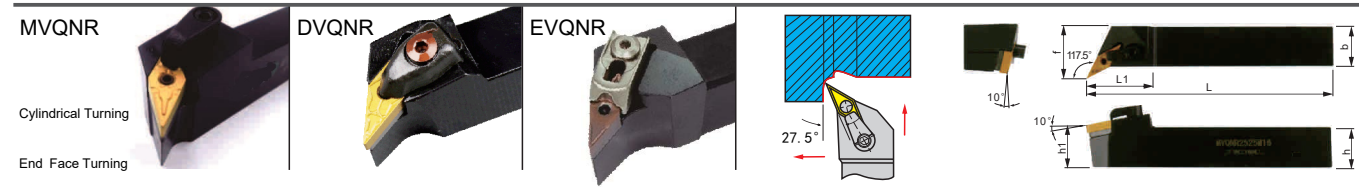

R-Type

Ordering code	Dimensions						Insert	Pin	Shim	Wrench	Screw	Clamp	Stock	
	h	b	L	L1	h1	f							R	L
MVQNR/L 1616H16	16	16	100	30	16	20	VN..1604..	230003	230029	230046 230048	230063	230135	●	●
2020K16	20	20	125	28	20	25							●	●
2525M16	25	25	150	30	25	32							●	●
3232P16	32	32	170	30	32	40							●	●
Ordering code	Dimensions						Insert	Shim Screw	Shim	Wrench	Clamp Screw	Clamp	Stock	
h	b	L	L1	h1	f	R							L	
DVQNR/L 1616H16	16	16	100	40	16	20	VN..1604..	230013	230029	230048	230108	230138	○	○
2020K16	20	20	125	40	20	25							○	○
2525M16	25	25	150	40	25	32							○	○
3232P16	32	32	170	40	32	40							○	○
Ordering code	Dimensions						Insert	Pin	Shim	Wrench	Clamp Screw	Clamp	Stock	
h	b	L	L1	h1	f	R							L	
EVQNR/L 2020K16	20	20	125	40	20	25	VN..1604..	230005	230029	230047 230049	230112	230146	○	○
2525M16	25	25	150	40	25	32							○	○
3232P16	32	32	170	40	32	40							○	○

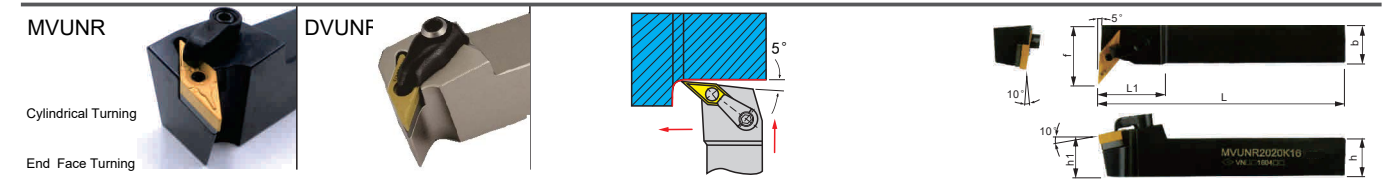

R-Type

Ordering code	Dimensions						Insert	Pin	Shim	Wrench	Screw	Clamp	Stock	
	h	b	L	L1	h1	f							R	L
MVUNR/L 2020K16	20	20	125	28	20	25	VN..1604..	230003	230029	230046 230048	230063	230135	●	●
2525M16	25	25	150	30	25	32							●	●
3232P16	32	32	170	30	32	40							●	●
Ordering code	Dimensions						Insert	Shim Screw	Shim	Wrench	Clamp Screw	Clamp	Stock	
h	b	L	L1	h1	f	R							L	
DVUNR/L 2020K16	20	20	125	35	20	30	VN..1604..	230013	230029	230048	230108	230138	○	○
2525M16	25	25	150	35	25	32							○	○
3232P16	32	32	170	35	32	40							○	○

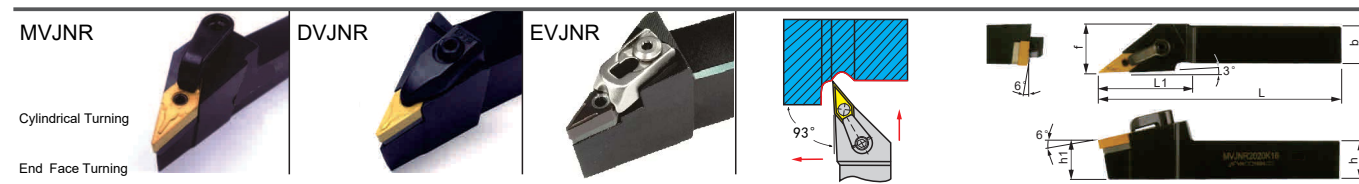

R-Type

Ordering code	Dimensions						Insert	Pin	Shim	Wrench	Screw	Clamp	Stock	
	h	b	L	L1	h1	f							R	L
MVJNR/L 1616H16	16	16	100	30	16	20	VN..1604..	230003	230029	230046 230048	230063	230135	●	●
2020K16	20	20	125	28	20	25							●	●
2525M16	25	25	150	30	25	32							●	●
3232P16	32	32	170	30	32	40							●	●
Ordering code	Dimensions						Insert	Shim Screw	Shim	Wrench	Clamp Screw	Clamp	Stock	
h	b	L	L1	h1	f	R							L	
DVJNR/L 1616K16	16	16	125	48	16	20	VN..1604..	230013	230029	230048	230108	230139	○	○
2020K16	20	20	125	48	20	25							○	○
2525M16	25	25	150	48	25	32							○	○
3232P16	32	32	170	48	32	40							○	○
Ordering code	Dimensions						Insert	Pin	Shim	Wrench	Clamp Screw	Clamp	Stock	
h	b	L	L1	h1	f	R							L	
EVJNR/L 2020K16	20	20	125	48	20	25	VN..1604..	230005	230029	230047 230049	230112	230146	○	○
2525M16	25	25	150	48	25	32							○	○
3232P16	32	32	170	48	32	40							○	○

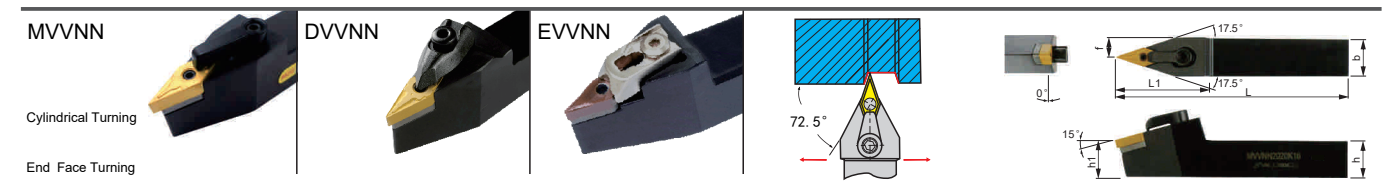

R-Type

Ordering code	Dimensions						Insert	Pin	Shim	Wrench	Screw	Clamp	Stock	
	h	b	L	L1	h1	f							R	L
MVVNN 1616H16	16	16	100	30	16	10	VN..1604..	230003	230029	230046 230048	230063	230135	●	●
2020K16	20	20	125	28	20	10							●	●
2525M16	25	25	150	30	25	12.5							●	●
3232P16	32	32	170	30	32	16							●	●
Ordering code	Dimensions						Insert	Shim Screw	Shim	Wrench	Clamp Screw	Clamp	Stock	
h	b	L	L1	h1	f	R							L	
DVVNN 1616K16	16	16	125	48	16	8	VN..1604..	230013	230029	230048	230108	230139	○	○
2020K16	20	20	125	48	20	10							○	○
2525M16	25	25	150	48	25	12.5							○	○
3232P16	32	32	170	48	32	20							○	○
Ordering code	Dimensions						Insert	Pin	Shim	Wrench	Clamp Screw	Clamp	Stock	
h	b	L	L1	h1	f	R							L	
EVVNN 2020K16	20	20	125	48	20	10	VN..1604..	230005	230029	230047 230049	230112	230146	○	○
2525M16	25	25	150	48	25	12.5							○	○
3232P16	32	32	170	48	32	20							○	○

M | D | E | P Type Cylindrical Turning Tool

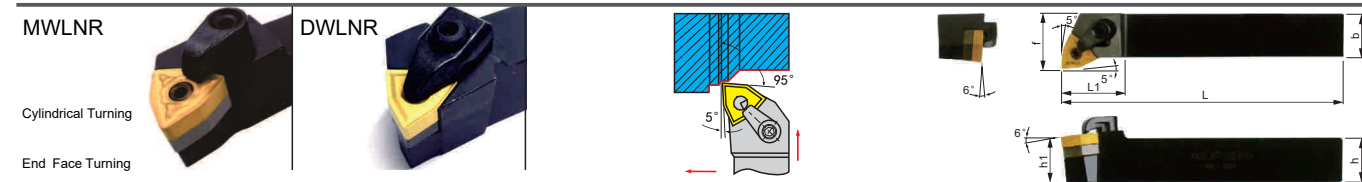

Ordering code	Dimensions						Insert	Pin	Shim	Wrench	Screw	Clamp	Stock	
	h	b	L	L1	h1	f							R	L
MWLNR/L 1616H06	16	16	100	31.5	16	20	WN..0604..	230003	230030	230046 230048	230063	230131	○	○
2020K06	20	20	125	33	20	25							○	○
2525M06	25	25	150	33	25	32							○	○
1616H08	16	16	100	31.5	16	20							○	○
2020K08	20	20	125	39	20	25							○	○
2525M08	25	25	150	40	25	32							○	○
3232P08	32	32	170	42	32	40	○	○						

Ordering code	Dimensions						Insert	Shim Screw	Shim	Wrench	Clamp Screw	Clamp	Stock	
	h	b	L	L1	h1	f							R	L
DWLNR/L 1616H06	16	16	100	28	16	20	WN..0604..	230013	230030	230048	230108	230138	○	○
2020K06	20	20	125	26	20	25							○	○
2525M06	25	25	150	32	25	32							○	○
3232P06	32	32	170	40	32	40							○	○
1616H08	16	16	100	31	16	20							○	○
2020K08	20	20	125	28	20	25							○	○
2525M08	25	25	150	32	25	32	○	○						
3232P08	32	32	170	32	32	40	○	○						

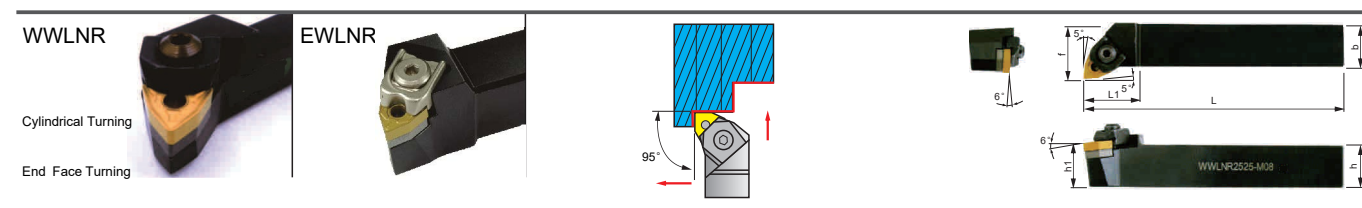

Ordering code	Dimensions						Insert	Pin	Shim	Wrench	Screw	Clamp	Stock	
	h	b	L	L1	h1	f							R	L
WWLNR/L 1616H08	16	16	100	38	16	20	WN..0804..	CT618-W	230031	230048 230049	230110	230149	○	○
2020K08	20	20	125	38	20	25							○	○
2525M08	25	25	150	38	25	32							○	○
3232P08	32	32	170	38	32	40							○	○

Ordering code	Dimensions						Insert	Pin	刀垫 Shim	Wrench	Clamp Screw	Clamp	Stock	
	h	b	L	L1	h1	f							R	L
EWLNR/L 1616H08	16	16	100	38	16	25	WN..0804..	230015	230031	230048 230049	230112	230147	○	○
2020K08	20	20	125	38	20	25							○	○
2525M08	25	25	150	38	25	32							○	○
3232P08	32	32	170	38	32	40							○	○

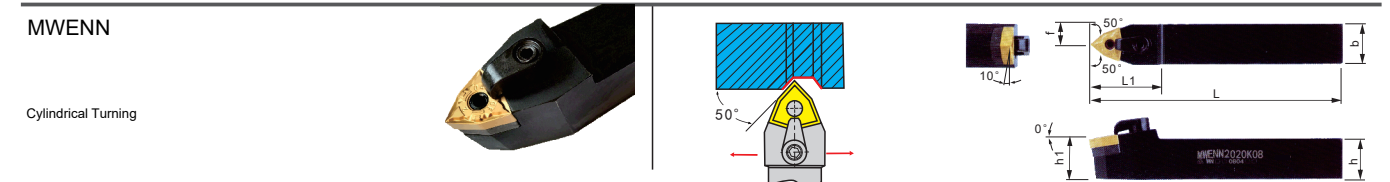

Ordering code	Dimensions						Insert	Pin	Shim	Wrench	Screw	Clamp	Stock	
	h	b	L	L1	h1	f							R	L
MWENN 1616H08	16	16	100	33	16	8	WN..0804..	230007	230031	230047 230048	230063	230131	○	○
2020K08	20	20	125	33	20	10							○	○
2525M08	25	25	150	33	25	12.5							○	○
3232P08	32	32	170	33	32	16							○	○

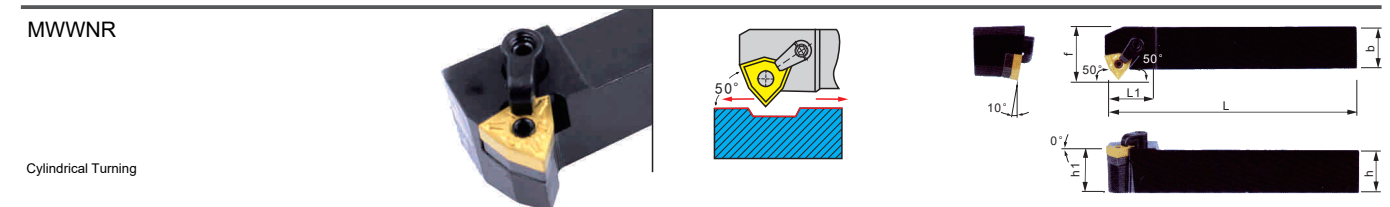

Ordering code	Dimensions						Insert	Pin	Shim	Wrench	Screw	Clamp	Stock	
	h	b	L	L1	h1	f							R	L
MWWNR/L 1616H08	16	16	100	33	16	20	WN..0804..	230007	230031	230047 230048	230063	230131	○	○
2020K08	20	20	125	33	20	25							○	○
2525M08	25	25	150	33	25	32							○	○
3232P08	32	32	170	33	32	40							○	○

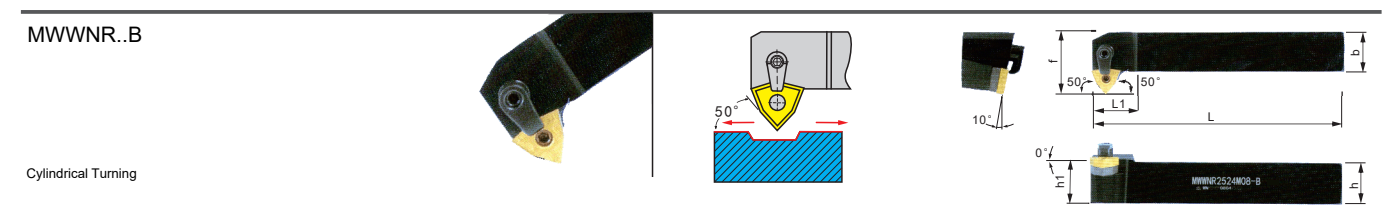

Ordering code	Dimensions						Insert	Pin	Shim	Wrench	Screw	Clamp	Stock	
	h	b	L	L1	h1	f							R	L
MWWNR/L 2020K08-B	20	20	125	26	20	33.5	WN..0804..	230007	230031	230047 230048	230063	230131	○	○
2524M08-B	25	24	150	26	25	37.5							○	○

S Type Cylindrical Turning Tool

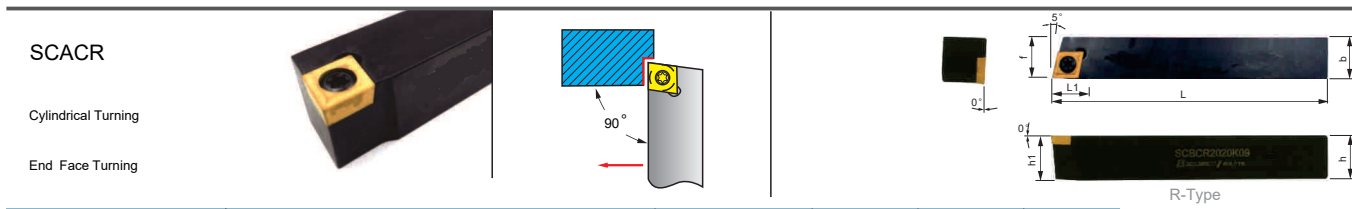

Ordering code	Dimensions						Wrench	Screw	Stock	
	h	b	L	L1	h1	f			R	L
SCACR/L 0808K06	8	8	125	10	8	8	230054	230075	•	•
1010K06	10	10	125	10	10	10			•	•
1212K09	12	12	125	13	12	12			•	•
1414K09	14	14	125	13	14	14			•	•
1616K09	16	16	125	13	16	16	230057	230092	•	•

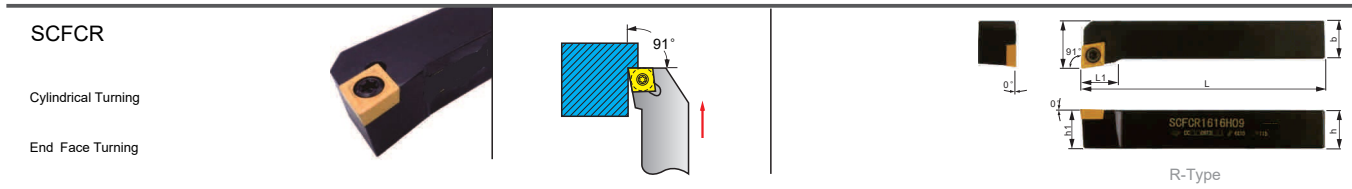

Ordering code	Dimensions						Wrench	Screw	Stock	
	h	b	L	L1	h1	f			R	L
SCFCR/L 1212H06	12	12	100	16	12	16	230054	230075	•	•
1414H09	14	14	100	20	14	16			•	•
1616H09	16	16	100	20	16	20			•	•
2020K09	20	20	125	20	20	25			•	•
2525M12	25	25	150	25	25	32	230058	230101	•	•
3232P12	32	32	170	25	32	40			•	•

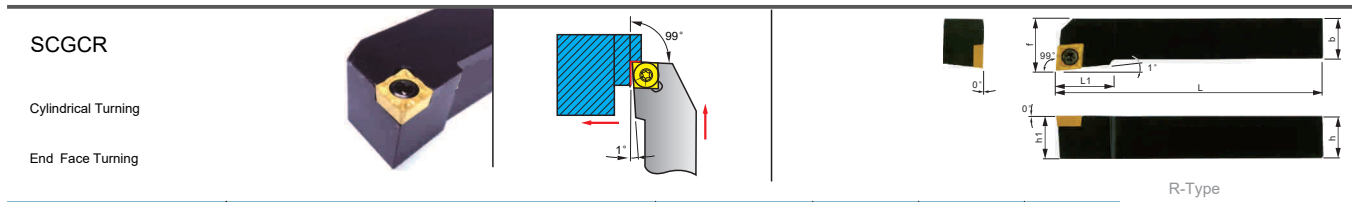

Ordering code	Dimensions						Wrench	Screw	Stock	
	h	b	L	L1	h1	f			R	L
SCGCR/L 0808F06	08	08	80	10	08	10	230054	230075	•	•
1010H06	10	10	100	12	10	12			•	•
1212H06	12	12	100	12	12	16			•	•
1212H09	12	12	100	18	12	16			•	•
1616H09	16	16	100	18	16	20	230057	230092	•	•
2020K09	20	20	125	20	20	25			•	•
2525M09	25	25	150	24	25	32			•	•
2020K12	20	20	125	23	20	25			•	•
2525M12	25	25	150	26	25	32	230058	230101	•	•
3232P12	32	32	170	28	32	40			•	•

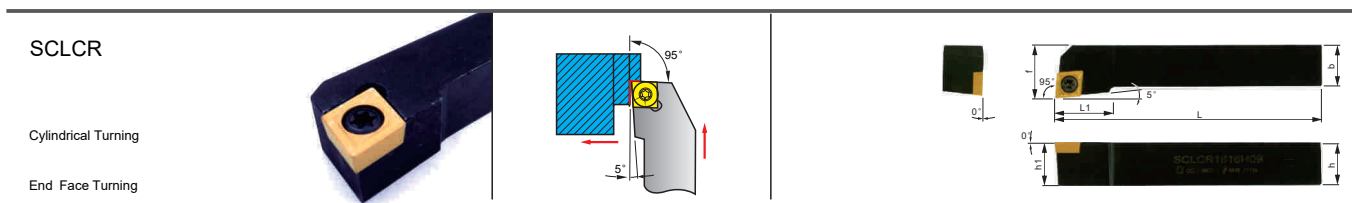

Ordering code	Dimensions						Wrench	Screw	Stock	
	h	b	L	L1	h1	f			R	L
SCLCR/L 0808F06	08	08	80	10	08	10	230054	230075	•	•
1010H06	10	10	100	12	10	12			•	•
1212H06	12	12	100	12	12	16			•	•
1212H09	12	12	100	18	12	16			•	•
1414H09	14	14	100	18	14	16	230057	230092	•	•
1616H09	16	16	100	18	16	20			•	•
2020K09	20	20	125	20	20	25			•	•
2525M09	25	25	150	24	25	32			•	•
2020K12	20	20	125	23	20	25	230058	230101	•	•
2525M12	25	25	150	26	25	32			•	•
3232P12	32	32	170	28	32	40			•	•

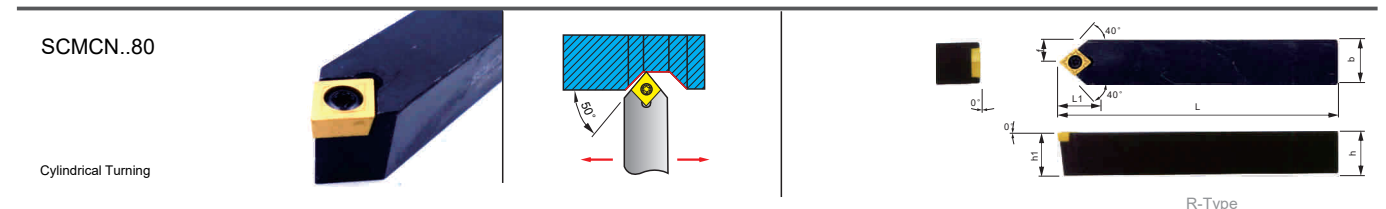

Ordering code	Dimensions						Wrench	Screw	Stock	
	h	b	L	L1	h1	f			R	L
SCMCN 0808H06	08	08	100	13	08	4	230054	230075	•	•
1010H06	10	10	100	13	10	5			•	•
1212H09	12	12	100	18	12	6			•	•
1414H09	14	14	100	18	14	7			•	•
1616H09	16	16	100	18	16	8	230057	230092	•	•
2020K09	20	20	125	18	20	10			•	•
2525M09	25	25	150	18	25	12.5			•	•
2020K12	20	20	125	23	20	20			•	•
2525M12	25	25	150	23	25	12.5	230058	230101	•	•

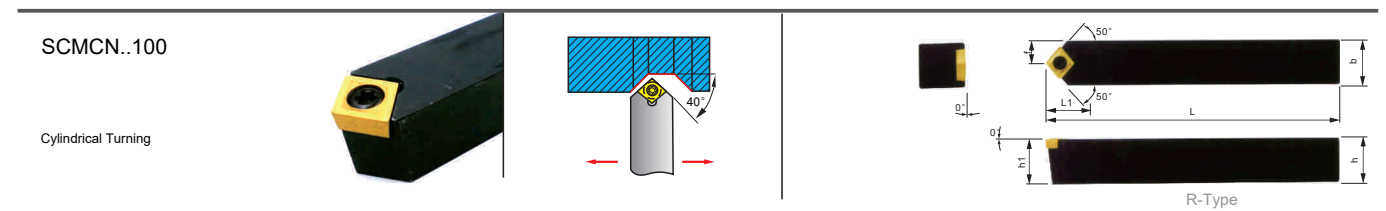

Ordering code	Dimensions						Wrench	Screw	Stock	
	h	b	L	L1	h1	f			R	L
SCMCN 1010H06-100	10	10	100	13	10	5	230054	230075	•	•
1212H09-100	12	12	100	18	12	6			•	•
1414H09-100	14	14	100	18	14	7			•	•
1616H09-100	16	16	100	18	16	8			•	•
2020K09-100	20	20	125	18	20	10	230057	230092	•	•
2525M09-100	25	25	150	18	25	12.5			•	•
2020K12-100	20	20	125	23	20	20			•	•
2525M12-100	25	25	150	23	25	12.5			•	•

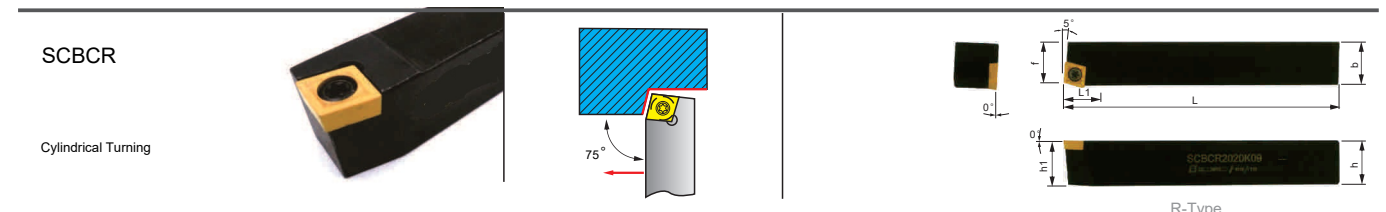

Ordering code	Dimensions						Wrench	Screw	Stock	
	h	b	L	L1	h1	f			R	L
SCBCR/L 1212H09	12	12	100	13	12	9.5	230057	230092	•	•
1616H09	16	16	100	15	16	13			•	•
2020K09	20	20	125	12	20	17			•	•
2525M09	25	25	150	12	25	22			•	•
1616H12	16	16	100	20	16	13	230058	230101	•	•
2020K12	20	20	125	16	20	17			•	•
2525M12	25	25	150	16	25	22			•	•

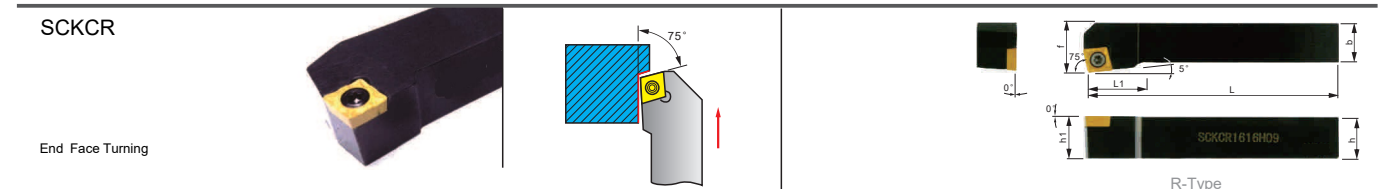

Ordering code	Dimensions						Wrench	Screw	Stock	
	h	b	L	L1	h1	f			R	L
SCKCR/L 1212H09	12	12	100	20	12	16	230057	230092	•	•
1414H09	14	14	100	20	14	16			•	•
1616H09	16	16	100	20	16	20			•	•
2020K09	20	20	125	23	20	25			•	•
2525M09	25	25	150	23	25	32	230058	230101	•	•
2020K12	20	20	125	23	20	25			•	•
2525M12	25	25	150	25	25	32			•	•

S Type Cylindrical Turning Tool

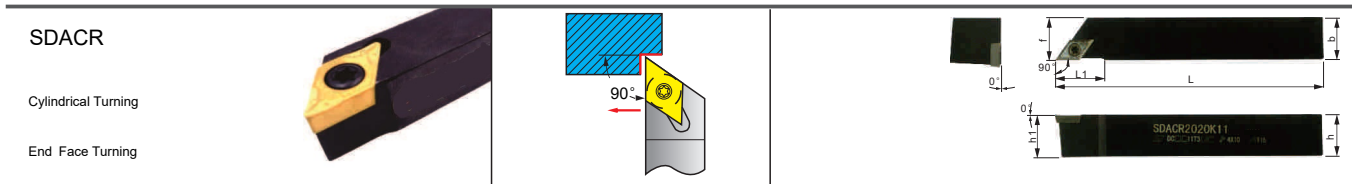

Ordering code	Dimensions						Insert	Wrench	Screw	Stock	
	h	b	L	L1	h1	f				R	L
SDACR/L 0808H07	8	8	100	15	8	8	DC..0702..	230054	230075	•	•
1010H07	10	10	100	15	10	10				•	•
1212H07	12	12	100	15	12	12				•	•
1212H11	12	12	100	22	12	12				•	•
1414H11	14	14	100	22	14	14				•	•
1616H11	16	16	100	22	16	16	DC..11T3..	230057	230092	•	•
2020K11	20	20	125	22	20	20				•	•
2525M11	25	25	150	22	25	25				•	•

R-Type

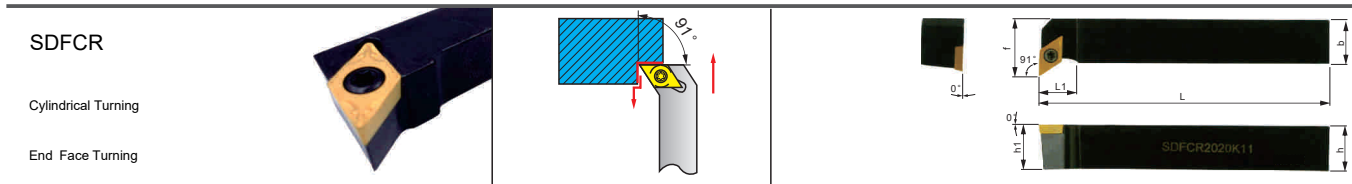

Ordering code	Dimensions						Insert	Wrench	Screw	Stock	
	h	b	L	L1	h1	f				R	L
SDFCR/L 1212H07	12	12	100	8	12	16	DC..0702..	230054	230075	•	•
1616H11	16	16	100	14	16	20				•	•
2020K11	20	20	125	14	20	25	DC..11T3..	230057	230092	•	•

R-Type

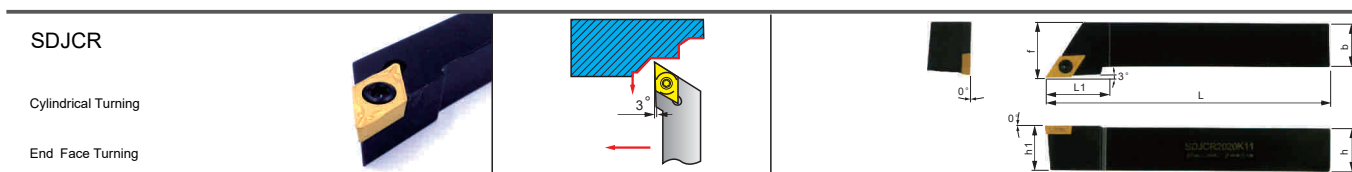

Ordering code	Dimensions						Insert	Wrench	Screw	Stock				
	h	b	L	L1	h1	f				R	L			
SDJCR/L 1010H07	10	10	100	14	10	12	DC..0702..	230054	230075	•	•			
1212H07	12	12	100	14	12	16				•	•			
1616H07	16	16	100	14	16	20				•	•			
1212H11	12	12	100	20	12	16				DC..11T3..	230057	230092	•	•
1414H11	14	14	100	20	14	16							•	•
1616H11	16	16	100	20	16	20	•	•						
2020K11	20	20	125	20	20	25	•	•						
2525M11	25	25	150	22	25	32	•	•						
3232P11	32	32	170	23	32	40	•	•						
4040R11	40	40	200	25	40	50	•	•						

R-Type

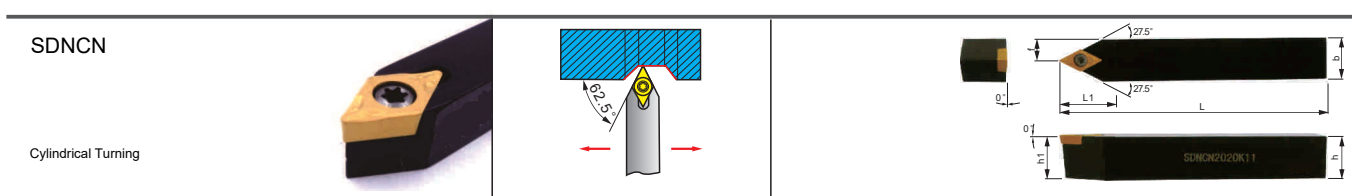

Ordering code	Dimensions						Insert	Wrench	Screw	Stock	
	h	b	L	L1	h1	f				R	L
SDNCN 1010H07	10	10	100	14	10	5	DC..0702..	230054	230075	•	•
1212H07	12	12	100	14	12	6				•	•
1212H11	12	12	100	21	12	6	DC..11T3..	230057	230092	•	•
1414H11	14	14	100	21	14	7				•	•
1616H11	16	16	100	21	16	8				•	•
2020K11	20	20	125	21	20	10				•	•

R-Type

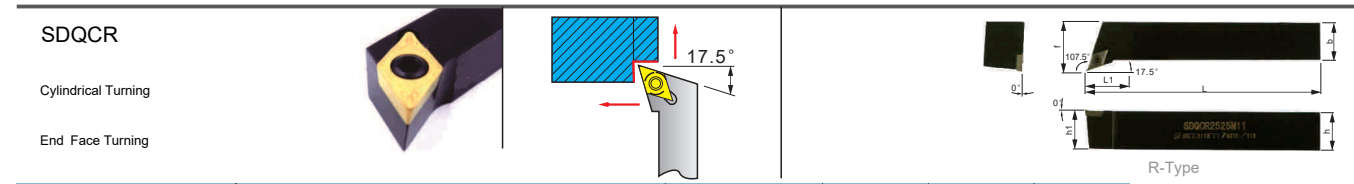

Ordering code	Dimensions						Insert	Wrench	Screw	Stock				
	h	b	L	L1	h1	f				R	L			
SDQCR/L 1010H07	10	10	100	13	10	12	DC..0702..	230054	230075	•	•			
1212H07	12	12	100	13	12	16				•	•			
1212H11	12	12	100	14	12	16				DC..11T3..	230057	230092	•	•
1616H11	16	16	100	14	16	20							•	•
2020K11	20	20	125	16	20	25							•	•
2525M11	25	25	150	20	25	32	•	•						

R-Type

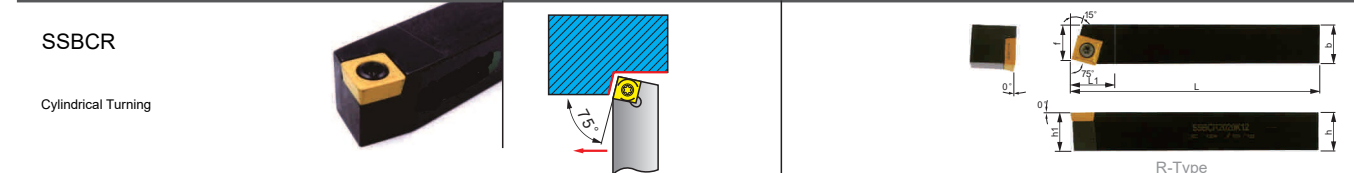

Ordering code	Dimensions						Insert	Wrench	Screw	Stock	
	h	b	L	L1	h1	f				R	L
SSBCR/L 1212H09	12	12	100	14	12	9.5	SC..09T3..	230057	230092	•	•
1616H09	16	16	100	14	16	13				•	•
2020K09	20	20	125	30	20	17				•	•
2525M09	25	25	150	32	25	22				•	•
2020K12	20	20	125	30	20	17				SC..1204..	230058
2525M12	25	25	150	25	22	22	•	•			

R-Type

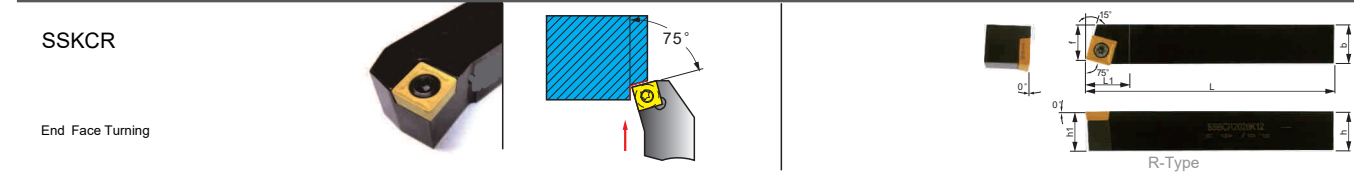

Ordering code	Dimensions						Insert	Wrench	Screw	Stock				
	h	b	L	L1	h1	f				R	L			
SSKCR/L 1212H09	12	12	100	15	12	16	SC..09T3..	230057	230092	•	•			
1616H09	16	16	100	20	16	20				•	•			
2020K09	20	20	125	25	20	25				•	•			
2525M09	25	25	150	22	25	32				SC..1204..	230058	230101	•	•
2020K12	20	20	125	20	20	25							•	•

R-Type

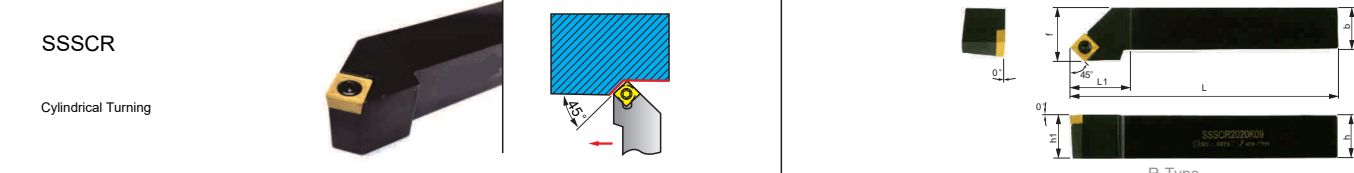

Ordering code	Dimensions						Insert	Wrench	Screw	Stock				
	h	b	L	L1	h1	f				R	L			
SSSCR/L 1212H09	12	12	100	16	12	16	SC..09T3..	230057	230092	•	•			
1616H09	16	16	100	16	16	20				•	•			
2020K09	20	20	125	18	20	25				•	•			
2525M09	25	25	150	26	25	32				SC..1204..	230058	230101	•	•
2525M12	25	25	150	25	25	32							•	•

R-Type

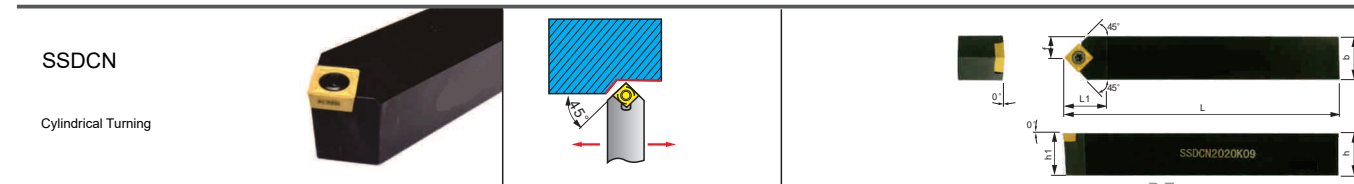

Ordering code	Dimensions						Insert	Wrench	Screw	Stock	
	h	b	L	L1	h1	f				R	L
SSDCN 1212H09	12	12	100	16	12	6	SC..09T3..	230057	230092	•	•
1414H09	14	14	100	16	14	7				•	•
1616H09	16	16	100	16	16	8				•	•
2020K09	20	20	125	16	20	10				•	•
2525M09	25	25	150	16	25	12.5				•	•

R-Type

S Type Cylindrical Turning Tool

SRAP(C)R

Cylindrical Turning



R-Type

Ordering code	Dimensions						Insert	Wrench	Screw	Stock		
	h	b	L	L1	h1	f				R	L	
SRAP(C)R/L	1616H08	16	16	100	16	16	RP..08T2..	230056	230078	•	•	
	2020K08	20	20	125	16	20				20.5	•	•
	2525M08	25	25	150	16	25				25.5	•	•
	2020K10	20	20	125	20.3	20	RP..10T3..	230057	230086	•	•	
	2525M10	25	25	150	20.3	25				25.6	•	•
	2020K12	20	20	125	25	20				20.8	•	•
2525M12	25	25	150	25	25	25.8	RP..1204..	230057	230092	•	•	

SRDP(C)N

Cylindrical Turning

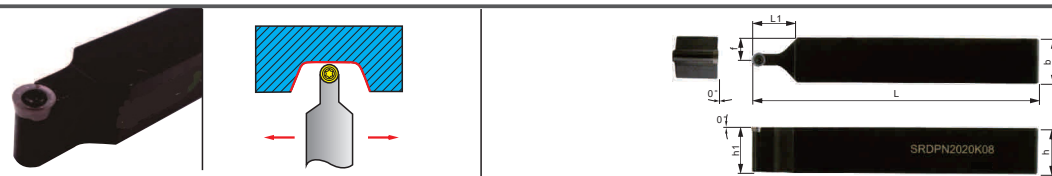

R-Type

Ordering code	Dimensions						Insert	Wrench	Screw	Stock		
	h	b	L	L1	h1	f				R	L	
SRDP(C)N	1616H08	16	16	100	16	16	RP..08T2..	230056	230078	•	•	
	2020K08	20	20	125	16	20				10	•	•
	2525M08	25	25	150	16	25				12.5	•	•
	1010H10	10	10	100	20.3	10	RP..10T3..	230057	230086	•	•	
	1616H10	16	16	100	20.3	16				8	•	•
	2020K10	20	20	125	20.3	20				10	•	•
2525M10	25	25	150	20.3	25	12.5	•	•				
3232P10	32	32	170	20.3	32	16	•	•				
2020K12	20	20	125	25	20	10	RP..1204..	230057	230092	•	•	
2525M12	25	25	150	25	25	12.5				•	•	

SRGP(C)R

Cylindrical Turning

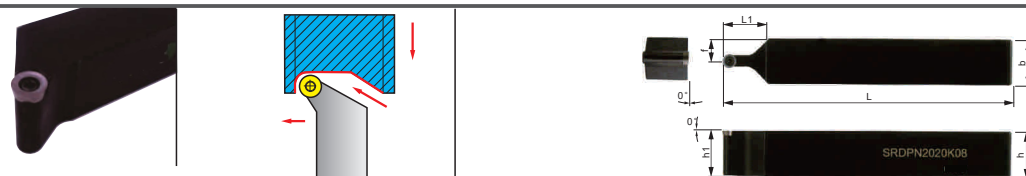

R-Type

Ordering code	Dimensions						Insert	Wrench	Screw	Stock		
	h	b	L	L1	h1	f				R	L	
SRGP(C)R/L	1212H05	12	12	100	9.5	12	RP..0502..	230052	230072	•	•	
	1616H05	16	16	100	9.5	16				20	•	•
	2020K05	20	20	125	11.2	20				25	•	•
	2525M05	25	25	150	14.7	25				32	•	•
	1212H06	12	12	100	10	12	RP..0602..	230054	230074	•	•	
	1616H06	16	16	100	10	16				20	•	•
	2020K06	20	20	125	12	20				25	•	•
	2525M06	25	25	150	15	25				32	•	•
	1616H08	16	16	100	11	16	RP..08T2..	230054	230078	•	•	
	2020K08	20	20	125	12.7	20				25	•	•
	2525M08	25	25	150	16.2	25				32	•	•
	1616H10	16	16	100	11	16				20	•	•
2020K10	20	20	125	12.7	20	25	RP..10T3..	230054	230092	•	•	
2525M10	25	25	150	16.2	25	32				•	•	
2020K12	20	20	125	13	20	25	RP..1204..	230057	230092	•	•	
2525M12	25	25	150	17	25	32				•	•	

STECR

Cylindrical Turning

End Face Turning



R-Type

Ordering code	Dimensions						Insert	Wrench	Screw	Stock		
	h	b	L	L1	h1	f				R	L	
STECR/L	1616H11	16	16	100	80	10	TC..1102..	230054	230075	•	•	
	2020K11	20	20	125	100	12				20	•	•
	2525M11	25	25	150	120	16				25	•	•
	2020K16	20	20	125	100	16	TC..16T3..	230057	230085	•	•	
	2525M16	25	25	150	120	20				25	•	•
	3232P16	32	32	170	135	25				32	•	•

STGCR

Cylindrical Turning

End Face Turning

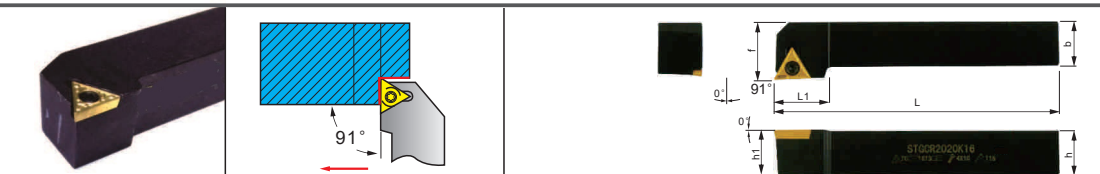

R-Type

Ordering code	Dimensions						Insert	Wrench	Screw	Stock		
	h	b	L	L1	h1	f				R	L	
STGCR/L	0808H09	8	8	100	10	8	TC..0902..	230052	230072	•	•	
	1010H09	10	10	100	12	10				12	•	•
	1212H11	12	12	100	16	12				16	•	•
	1616H11	16	16	100	20	12	TC..1102..	230054	230075	•	•	
	1616H16	16	16	100	22	16				20	•	•
	2020K16	20	20	125	22	20				25	•	•
2525M16	25	25	150	22	20	32	TC..16T3..	230057	230092	•	•	
3232P16	32	32	170	22	25	40				•	•	

STFCR

Cylindrical Turning

End Face Turning

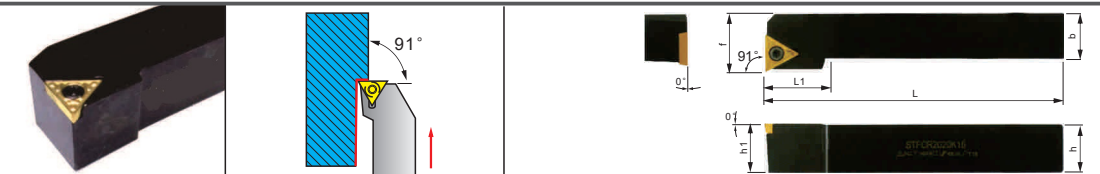

R-Type

Ordering code	Dimensions						Insert	Wrench	Screw	Stock		
	h	b	L	L1	h1	f				R	L	
STFCR/L	1010H09	10	10	100	12	10	TC..0902..	230052	230072	•	•	
	1212H11	12	12	100	16	12				16	•	•
	1414H11	14	14	100	16	14				16	•	•
	1616H11	16	16	100	16	16	TC..16T3..	230057	230092	•	•	
	1616H16	16	16	100	16	16				20	•	•
	2020K16	20	20	125	22	20				25	•	•
2525M16	25	25	150	22	25	32	•	•				

STWCR

Cylindrical Turning

End Face Turning

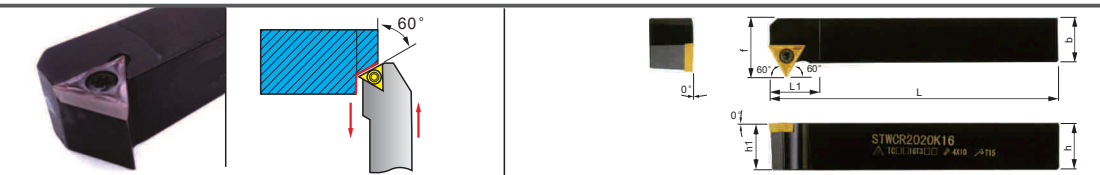

R-Type

Ordering code	Dimensions						Insert	Wrench	Screw	Stock		
	h	b	L	L1	h1	f				R	L	
STWCR/L	1212H11	12	12	100	8	12	TC..1102..	230054	230075	•	•	
	1616H11	16	16	100	8	16				19.3	•	•
	2020K11	20	20	125	8	20				23.3	•	•
	2525M11	25	25	150	8	25	TC..16T3..	230057	230092	•	•	
	1616H16	16	16	100	12	16				21	•	•
	2020K16	20	20	125	12	20				26	•	•
2525M16	25	25	150	12	25	31	•	•				
3232P16	32	32	170	12	32	38	•	•				

S Type Cylindrical Turning Tool

SVJBR

Cylindrical Turning

End Face Turning

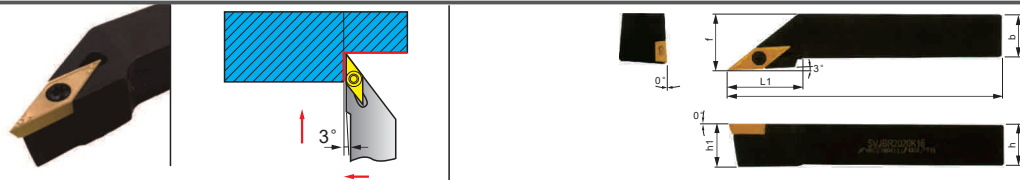

R-Type

Ordering code	Dimensions						Insert	Wrench	Screw	Stock	
	h	b	L	L1	h1	f				R	L
SVJBR/L 1212H11	12	12	100	25	12	16	VB..1103..	230054	230074	•	•
1616H11	16	16	100	28	16	20				•	•
2020K11	20	20	125	32	20	25				•	•
1616H16	16	16	100	32	16	20	VB..1604..	230057	230092	•	•
2020K16	20	20	125	32	20	25				•	•
2525M16	25	25	150	32	25	32				•	•
3232P16	32	32	170	40	32	40				•	•

SVJCR

Cylindrical Turning

End Face Turning

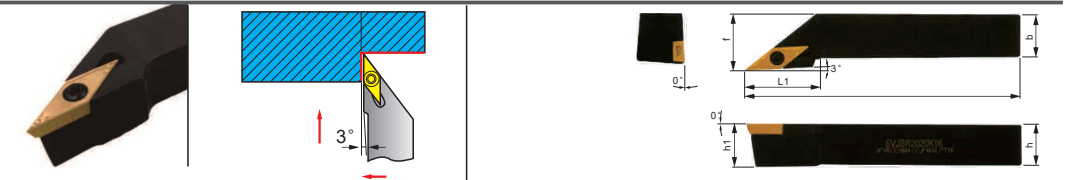

R-Type

Ordering code	Dimensions						Insert	Wrench	Screw	Stock	
	h	b	L	L1	h1	f				R	L
SVJCR/L 1212H11	12	12	100	25	12	16	VC..1103..	230054	230074	•	•
1616H11 2020K11	16	16	100	28	16	20				•	•
2020K11	20	20	125	32	20	25				•	•
1616H16	16	16	100	32	16	20	VC..1604..	230057	230092	•	•
2020K16	20	20	125	32	20	25				•	•
2525M16	25	25	150	32	25	32				•	•
3232P16	32	32	170	40	32	40				•	•

SVQBR

Cylindrical Turning

End Face Turning

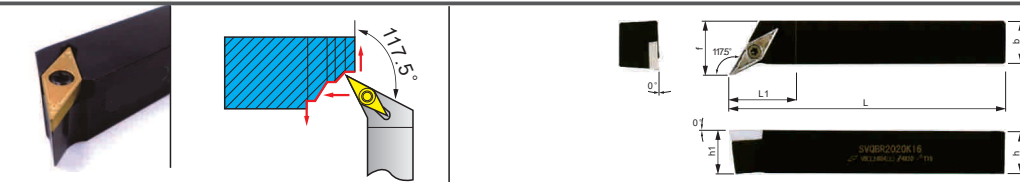

R-Type

Ordering code	Dimensions						Insert	Wrench	Screw	Stock	
	h	b	L	L1	h1	f				R	L
SVQBR/L 1212H11	12	12	100	25	12	16	VB..1103..	230054	230074	•	•
1616H11	16	16	100	28	16	20				•	•
2020K11	20	20	125	32	20	25				•	•
1616H16	16	16	100	32	16	20	VB..1604..	230057	230092	•	•
2020K16	20	20	125	32	20	25				•	•
2525M16	25	25	150	32	25	32				•	•
3232P16	32	32	170	40	32	40				•	•

SVQCR

Cylindrical Turning

End Face Turning

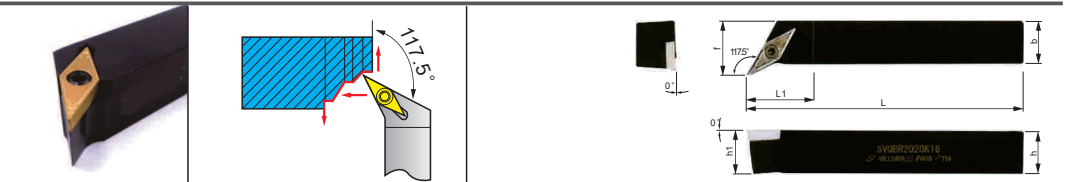

R-Type

Ordering code	尺寸 Dimensions						Insert	Wrench	Screw	Stock	
	h	b	L	L1	h1	f				R	L
SVQCR/L 1212H11	12	12	100	25	12	16	VC..1103..	230054	230074	•	•
1616H11 2020K11	16	16	100	28	16	20				•	•
2020K11	20	20	125	32	20	25				•	•
1616H16	16	16	100	32	16	20	VC..1604..	230057	230092	•	•
2020K16	20	20	125	32	20	25				•	•
2525M16	25	25	150	32	25	32				•	•
3232P16	32	32	170	40	32	40				•	•

SVUBR

Cylindrical Turning

End Face Turning

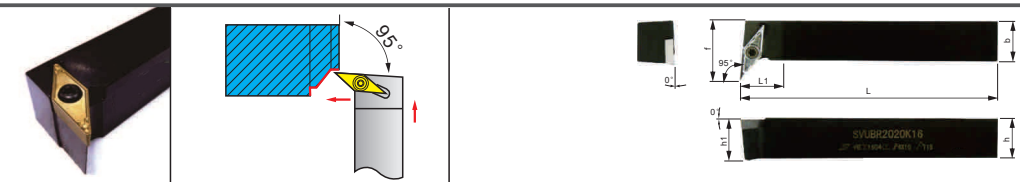

R-Type

Ordering code	Dimensions						Insert	Wrench	Screw	Stock	
	h	b	L	L1	h1	f				R	L
SVUBR/L 1212H11	12	12	100	12	12	16	VB..1103..	230054	230074	•	•
1616H11	16	16	100	12	16	20				•	•
2020K11	20	20	125	16	20	25				•	•
1616H16	16	16	100	20	16	30	VB..1604..	230057	230092	•	•
2020K16	20	20	125	20	20	30				•	•
2525M16	25	25	150	16	25	32				•	•
3232P16	32	32	170	16	32	40				•	•

SVUCR

Cylindrical Turning

End Face Turning

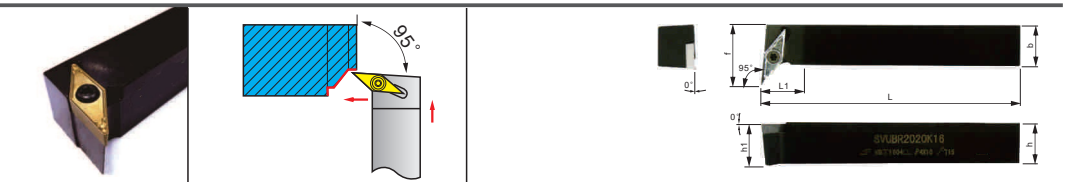

R-Type

Ordering code	Dimensions						Insert	Wrench	Screw	Stock	
	h	b	L	L1	h1	f				R	L
SVUCR/L 1212H11	12	12	100	12	12	16	VC..1103..	230054	230074	•	•
1616H11 2020K11	16	16	100	12	16	20				•	•
2020K11	20	20	125	16	20	25				•	•
1616H16	16	16	100	20	16	30	VC..1604..	230057	230092	•	•
2020K16	20	20	125	20	20	30				•	•
2525M16	25	25	150	16	25	32				•	•
3232P16	32	32	170	16	32	40				•	•

SVVBN

Cylindrical Turning

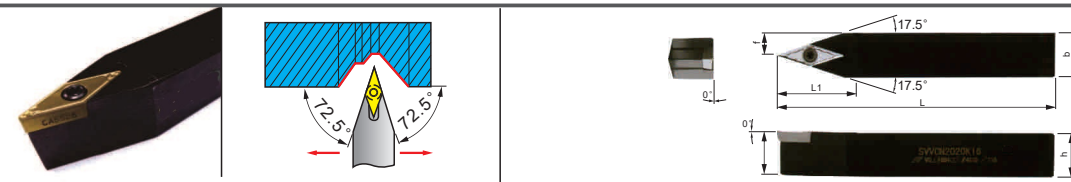

R-Type

Ordering code	Dimensions						Insert	Wrench	Screw	Stock	
	h	b	L	L1	h1	f				R	L
SVVBN 1010H11	10	10	100	25	10	5	VB..1103..	230054	230075	•	•
1212H11	12	12	100	28	12	6				•	•
1616H11	16	16	100	24	16	8				•	•
2020K11	20	20	125	24	20	10	VB..1604..	230057	230092	•	•
2525M11	25	25	150	24	25	12.5				•	•
1616H16	16	16	100	34	16	8				•	•
2020K16	20	20	125	34	20	10				•	•
2525M16	25	25	150	34	25	12.5				•	•
3232P16	32	32	170	34	32	16				•	•

SVVCN

Cylindrical Turning

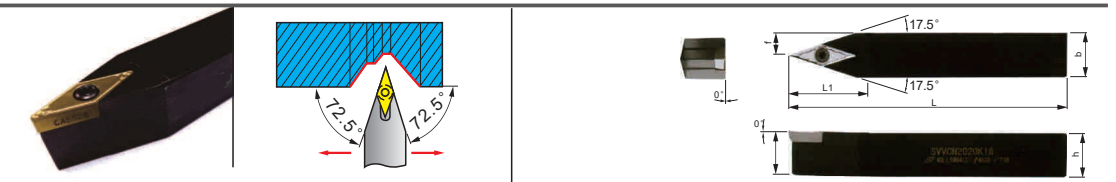

R-Type

Ordering code	Dimensions						Insert	Wrench	Screw	Stock	
	h	b	L	L1	h1	f				R	L
SVVCN 1010H11	10	10	100	25	10	5	VC..1103..	230054	230075	•	•
1212H11	12	12	100	28	12	6				•	•
1616H11	16	16	100	24	16	8				•	•
2020K11	20	20	125	24	20	10	VC..1604..	230057	230092	•	•
2525M11	25	25	150	24	25	12.5				•	•
1616H16	16	16	100	34	16	8				•	•
2020K16	20	20	125	34	20	10				•	•
2525M16	25	25	150	34	25	12.5				•	•
3232P16	32	32	170	34	32	16				•	•

Small bore turning tool

Insert Center Alignment

Internal Turning

Internal Back Turning

Internal Profiling Turning

Internal and End Face Turning

Common turning of outer circle and inner hole

Tool Categories:

- Boring:** DS-LBMB, S-SVNR, SVN, CH-LBML, LBMAR, SBQR, SBPR, SBFR, SBTR, SBUR, SBDR, STIR, SBWR, SBKR, SBCR, SMFR, SMFL, SMVR, MTJNR, SDJCR, C-SDJCR, T-SDJCR, H-SDJCR, SDXCR, C-SDXCR, T-SDXCR, H-SDXCR, DVXNR, EVXNR, SVJB(C)R, SCBCR, SVXB(C)R, C-SVXB(C)R, MTFNR, DTFNR, STFNR, STFCR, C-STFCR, T-STFCR, H-STFCR, STFPR, C-STFPR, T-STFPR, H-STFPR, MCLNR, DCLNR, ECLNR, SCLNR, C-MCLNR, SCLCR-A, SCLCR, C-SCLCR, E-SCLCR, T-SCLCR, H-SCLCR, C-SCLCR-A, MTLNR, ETLNR, STLNR, MTUNR, DTUNR, WTUNR, STUNR, STUBR, C-STUBR, H-STUBR, E-STUBR, STUP(C)R-A, STUCR, C-STUCR, E-STUCR, T-STUCR, H-STUCR, STUPR, MDUNR, DDUNR, EDUNR, SDUCR, C-SDUCR, T-SDUCR, H-SDUCR, MVUNR, DVUNR, EVUNR, SVUB(C)R, C-SVUB(C)R, MVLNR, DWLNR, EWLNR, SWLNR, SWUBR, SWLCR.
- Internal Turning:** MTWNR, STWNR, STWC(P)R, C-STWCR, T-STWCR, H-STWCR, MCWNR, SCWCR, H-SCWCR, MSSNR, SSSCR, H-SSSCR, MDWNR, SDWCR, MVWNR, SVWB(C)R, SBXR, SCZCR, MDZNR, SDZCR, C-SDZCR, MVZNR, SVZB(C)R, C-SVZB(C)R, MCKNR, DCKNR, ECKNR, SCKNR, SCKCR, C-SCKCR, T-SCKCR, H-SCKCR, MSKNR, DSKNR, SSKCR, C-SSKCR, H-SSKCR.
- Internal End Face Turning:** S..MW08.., S..MC12..

Carbide small Internal boring tool

Boring Tools

- Processing diameter $\phi 2.2$
- Strengthened the standard inventory of "TBFS type" and "TBFB type" products
- Knife angle R has R0.05 and R0.15

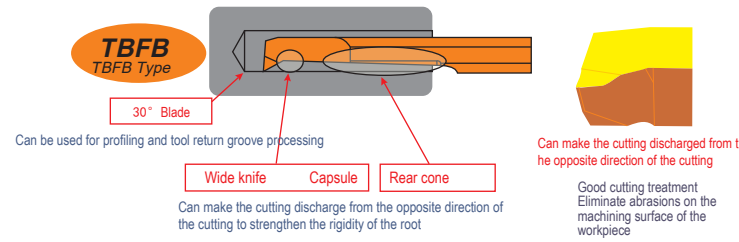
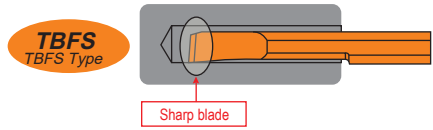

Groove Machining

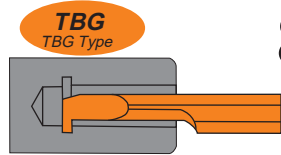

- Machining diameter $\phi 3$
- Strengthen the inventory of standard products with a groove width of 0.5 / 0.75 / 1.0 / 1.5mm

Thread Cutting

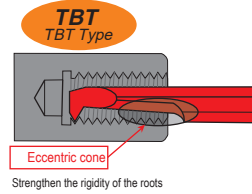

- Machinable thread M4
- Machinable pitch 0.5
- Thicken the roots to improve rigidity

Alloy Small Boring Tool

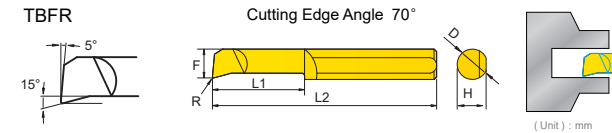
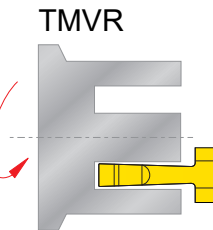
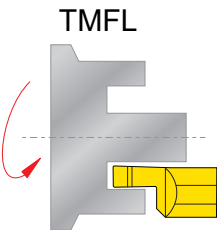
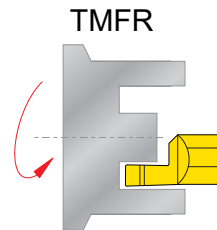
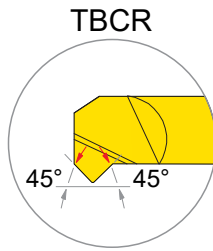
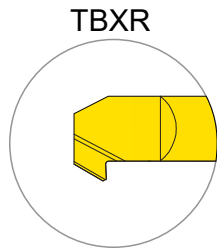
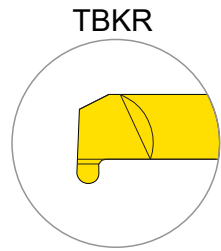
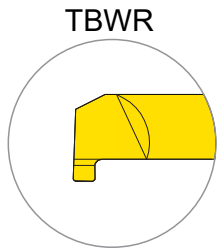
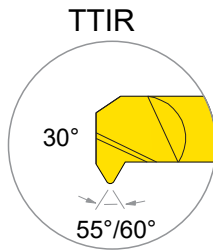
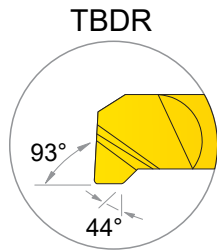
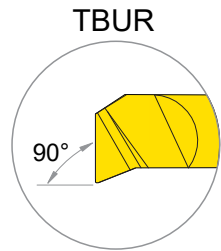
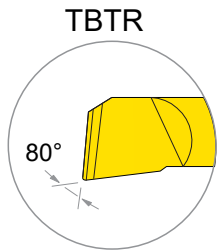
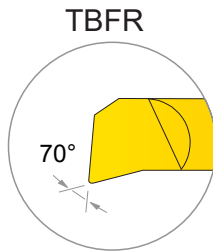
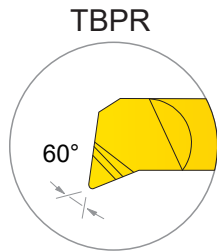
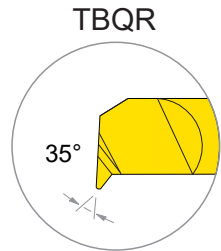

Model	F	L1	S	R	D	L2	H	Stock	Processing Diameter
TBFR10030R05-D4	0.8	3.0	0.2	0.05	D4	40	3.7	○	1mm
TBFR15050R10-D4	1.2	5.0	0.2	0.1	D4	40	3.7	○	1.5mm
TBFR20070R10-D4	1.7	7.0	0.35	0.1	D4	40	3.7	○	2mm
TBFR25070R10-D4	2.3	7.0	0.45	0.1	D4	40	3.7	○	2.5mm
TBFR30100R10-D4	2.7	10.0	0.45	0.1	D4	50	3.7	○	3mm
TBFR35150R15-D4	3.2	15.0	0.5	0.15	D4	50	3.7	○	3.5mm
TBFR40150R15-D4	3.7	15.0	0.5	0.15	D4	50	3.7	○	4mm
TBFR45150R15-D4	4.0	15.0	0.5	0.15	D4	50	3.7	○	4.5mm
TBFR50200R20-D6	4.7	20.0	0.9	0.20	D6	50	5.7	○	5mm
TBFR55200R20-D6	5.2	20.0	0.9	0.20	D6	50	5.7	○	5.5mm
TBFR60200R20-D6	5.7	20.0	0.9	0.20	D6	50	5.7	○	6mm
TBFR80400R20-D8	7.5	40.0	1.2	0.20	D8	60	7.7	○	8mm

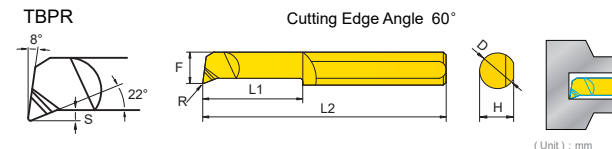

Model	F	L1	S	R	D	L2	H	Stock	Processing Diameter
TBPR 10040R05-D4	0.85	4.0	0.15	0.05	D4	40	3.7	○	1mm
TBPR 10040R05-D4	0.85	4.0	0.15	0.05	D4	40	3.7	○	1mm
TBPR 20060R05-D4	1.8	6.0	0.30	0.05	D4	40	3.7	○	2mm
TBPR 20060R05-D4	1.8	6.0	0.30	0.05	D4	40	3.7	○	2mm
TBPR 30060R05-D4	2.7	6.0	0.30	0.05	D4	50	3.7	○	3mm
TBPR 30060R05-D4	2.7	6.0	0.30	0.05	D4	50	3.7	○	3mm
TBPR 30060R05-D4	2.7	6.0	0.30	0.05	D4	50	3.7	○	3mm
TBPR 30100R05-D4	2.7	10.0	0.30	0.05	D4	50	3.7	○	3mm
TBPR 30100R05-D4	2.7	10.0	0.30	0.05	D4	50	3.7	○	3mm
TBPR 30100R05-D4	2.7	10.0	0.30	0.05	D4	50	3.7	○	3mm
TBPR 40080R10-D4	3.7	8.0	0.40	0.05	D4	50	3.7	○	4mm
TBPR 40080R10-D4	3.7	8.0	0.40	0.05	D4	50	3.7	○	4mm
TBPR 40080R10-D4	3.7	8.0	0.40	0.05	D4	50	3.7	○	4mm
TBPR 40150R05-D4	3.7	15.0	0.40	0.05	D4	50	3.7	○	4mm
TBPR 40150R05-D4	3.7	15.0	0.40	0.05	D4	50	3.7	○	4mm
TBPR 40150R05-D4	3.7	15.0	0.40	0.05	D4	50	3.7	○	4mm
TBPR 50200R05-D5	4.7	20.0	0.50	0.05	D5	50	4.7	○	5mm
TBPR 50200R05-D5	4.7	20.0	0.50	0.05	D5	50	4.7	○	5mm
TBPR 50200R05-D5	4.7	20.0	0.50	0.05	D5	50	4.7	○	5mm
TBPR 60200R05-D6	5.7	20.0	0.50	0.10	D6	50	5.7	○	6mm
TBPR 60200R05-D6	5.7	20.0	0.50	0.10	D6	50	5.7	○	6mm
TBPR 60200R05-D6	5.7	20.0	0.50	0.10	D6	50	5.7	○	6mm
TBPR 70250R15-D7	6.5	25.0	0.50	0.15	D7	50	6.7	○	7mm
TBPR 80300R15-D8	7.5	30.0	0.50	0.15	D8	60	7.7	○	8mm
TBPR 80300R15-D8	7.5	30.0	0.50	0.15	D8	60	7.7	○	8mm

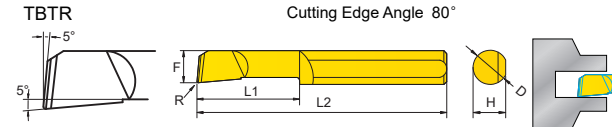

Model	F	L1	S	R	D	L2	H	Stock	Processing Diameter
TBTR 10040R05-D4	0.85	4.0	0.15	0.05	D4	40	3.7	○	1mm
TBTR 10040R05-D4	0.85	4.0	0.15	0.05	D4	40	3.7	○	1mm
TBTR 20060R05-D4	1.8	6.0	0.30	0.05	D4	40	3.7	○	2mm
TBTR 20060R05-D4	1.8	6.0	0.30	0.05	D4	40	3.7	○	2mm
TBTR 30060R05-D4	2.7	6.0	0.30	0.05	D4	50	3.7	○	3mm
TBTR 30060R05-D4	2.7	6.0	0.30	0.05	D4	50	3.7	○	3mm
TBTR 30060R05-D4	2.7	6.0	0.30	0.05	D4	50	3.7	○	3mm
TBTR 30100R05-D4	2.7	10.0	0.30	0.05	D4	50	3.7	○	3mm
TBTR 30100R05-D4	2.7	10.0	0.30	0.05	D4	50	3.7	○	3mm
TBTR 30100R05-D4	2.7	10.0	0.30	0.05	D4	50	3.7	○	3mm
TBTR 40080R10-D4	3.7	8.0	0.40	0.05	D4	50	3.7	○	4mm
TBTR 40080R10-D4	3.7	8.0	0.40	0.05	D4	50	3.7	○	4mm
TBTR 40080R10-D4	3.7	8.0	0.40	0.05	D4	50	3.7	○	4mm
TBTR 40150R05-D4	3.7	15.0	0.40	0.05	D4	50	3.7	○	4mm
TBTR 40150R05-D4	3.7	15.0	0.40	0.05	D4	50	3.7	○	4mm
TBTR 40150R05-D4	3.7	15.0	0.40	0.05	D4	50	3.7	○	4mm
TBTR 50200R05-D5	4.7	20.0	0.50	0.05	D5	50	4.7	○	5mm
TBTR 50200R05-D5	4.7	20.0	0.50	0.05	D5	50	4.7	○	5mm
TBTR 50200R05-D5	4.7	20.0	0.50	0.05	D5	50	4.7	○	5mm
TBTR 60200R05-D6	5.7	20.0	0.50	0.10	D6	50	5.7	○	6mm
TBTR 60200R05-D6	5.7	20.0	0.50	0.10	D6	50	5.7	○	6mm
TBTR 60200R05-D6	5.7	20.0	0.50	0.10	D6	50	5.7	○	6mm
TBTR 70250R15-D7	6.5	25.0	0.50	0.15	D7	50	6.7	○	7mm
TBTR 80300R15-D8	7.5	30.0	0.50	0.15	D8	60	7.7	○	8mm
TBTR 80300R15-D8	7.5	30.0	0.50	0.15	D8	60	7.7	○	8mm

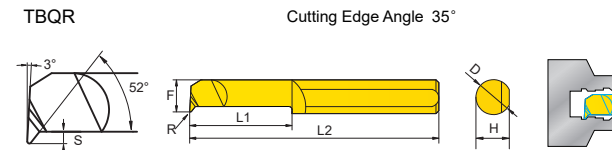

Model	F	L1	S	R	D	L2	H	Stock	Processing Diameter
TBQR 30060R05-D4	2.9	6.0	0.6	0.05	D4	50	3.7	○	3mm
TBQR 30100R05-D4	2.9	10.0	0.6	0.20	D4	50	3.7	○	3mm
TBQR 40100R10-D4	3.9	10.0	0.8	0.10	D4	50	3.7	○	4mm
TBQR 40100R10-D4	3.9	10.0	0.8	0.20	D4	50	3.7	○	4mm
TBQR 50150R10-D5	4.9	15.0	1.0	0.10	D5	50	4.7	○	5mm
TBQR 50150R10-D5	4.9	15.0	1.0	0.20	D5	50	4.7	○	5mm
TBQR 60150R10-D6	5.9	15.0	1.0	0.10	D6	50	5.7	○	6mm
TBQR 60150R10-D6	5.9	15.0	1.0	0.20	D6	50	5.7	○	6mm
TBQR 70200R10-D7	6.5	20.0	1.5	0.20	D7	50	6.7	○	7mm
TBQR 80250R10-D8	7.5	25.0	2.0	0.10	D8	60	7.7	○	8mm
TBQR 80250R10-D8	7.5	25.0	2.0	0.20	D8	60	7.7	○	8mm

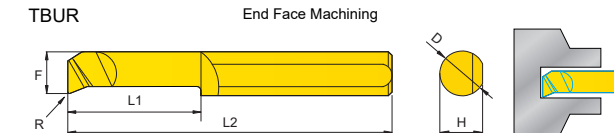

Model	F	L1	S	R	D	L2	H	F1	Stock	Processing Diameter
TBUR30100R10-D4	2.7	10.0	0.4	0.1	D4	50	3.7	1.3	○	3mm
TBUR40150R10-D4	3.7	15.0	0.5	0.1	D4	50	3.7	1.7	○	4mm
TBUR50200R20-D5	4.7	20.0	0.7	0.2	D5	50	4.7	2.1	○	5mm
TBUR60200R20-D6	5.7	20.0	1.0	0.2	D6	50	5.7	2.8	○	6mm
TBUR70250R10-D7	6.7	25.0	1.0	0.2	D7	50	6.7	3.2	○	7mm
TBUR80300R20-D8	7.7	30.0	1.0	0.2	D8	60	7.7	3.8	○	8mm

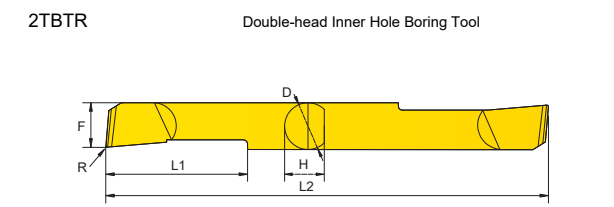

Model	F	L1	S	R	D	L2	H	Stock	Processing Diameter
2TBTR02050R05-D3	1.8	5.0	0.15	0.05	D3	50	2.7	○	2mm
2TBTR03150R10-D3	2.7	15.0	0.3	0.1	D3	50	3.7	○	3mm
2TBTR04150R15-D4	3.7	15.0	0.4	0.15	D4	50	3.7	○	4mm
2TBTR05250R10-D5	4.7	25.0	0.5	0.1	D5	70	4.7	○	5mm
2TBTR05250R20-D5	4.7	25.0	0.5	0.2	D5	70	4.7	○	5mm
2TBTR06250R10-D6	5.7	25.0	0.5	0.1	D6	70	5.7	○	6mm
2TBTR06250R20-D6	5.7	25.0	0.5	0.2	D6	70	5.7	○	6mm

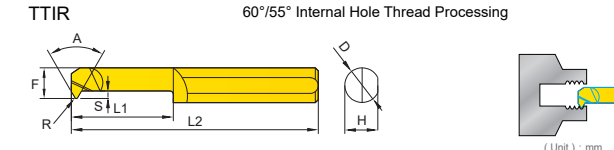

Model	F	L1	S	R	D	L2	American	Metric	Pitch	Processing Diameter	A	
TTIR 14050-60°	1.4	5.0	0.4	0.00	D4	50	UN-1/8-28	M2	0.25	0.45	1.5mm	60°
TTIR 18070-60°	1.8	7.0	0.6	0.00	D4	50	UN-3/8-24	M2.5	0.25	0.7	1.5mm	60°
TTIR 24070-60°	2.4	7.0	0.5	0.00	D4	50	UN-3/8-24	M3	0.25	0.6	2.5mm	60°
TTIR 30120-60°	3.0	12.0	0.85	0.03	D4	50	UN-1/2-20	M4	0.5	0.8	3.1mm	60°
TTIR 40150-60°	3.85	15.0	1.1	0.05	D4	50	UN-1/2-20	M5	0.5	1.0	4.0mm	60°
TTIR 50150-60°	4.8	15.0	1.5	0.05	D5	50	UN-1/4-28	M6	0.75	1.5	5.0mm	60°
TTIR 60200-60°	5.8	20.0	1.8	0.08	D6	50	UN-1/4-28	M8	1.0	1.75	6.0mm	60°
TTIR 80220-60°	7.8	22.0	2.2	0.08	D8	50	UN-1/8-36	M12	1.5	2.0	8.0mm	60°

55° Profile Angle Inch Thread

Model	F	L1	S	R	D	L2
-------	---	----	---	---	---	----

Carbide small Internal boring tool

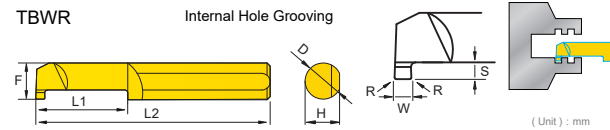

Model	W	S	L1	R	F	D	L2	H	Stock	Processing Diameter
TBWR05100R005-D4	0.5	1.0	10	0.05	3.8	D4	50	3.7	○	4mm
TBWR08100R005-D4	0.8	1.0	10	0.05	3.8	D4	50	3.7	○	4mm
TBWR10100R005-D4	1.0	1.5	10	0.05	3.8	D4	50	3.7	○	4mm
TBWR15100R005-D4	1.5	1.5	10	0.05	3.8	D4	50	3.7	○	4mm
TBWR10100R010-D5	1.0	1.5	10	0.1	4.8	D5	50	4.7	○	5mm
TBWR12100R010-D5	1.2	1.5	10	0.1	4.8	D5	50	4.7	○	5mm
TBWR15100R010-D5	1.5	2.0	10	0.1	4.8	D5	50	4.7	○	5mm
TBWR20100R010-D5	2.0	2.0	10	0.1	4.8	D5	50	4.7	○	5mm
TBWR10120R015-D6	1.0	2.0	12	0.15	5.8	D6	50	5.7	○	6mm
TBWR15120R015-D6	1.5	2.0	12	0.15	5.8	D6	50	5.7	○	6mm
TBWR20120R015-D6	2.0	2.0	12	0.15	5.8	D6	50	5.7	○	6mm
TBWR25160R015-D6	2.5	2.5	16	0.15	5.8	D6	50	5.7	○	6mm
TBWR15160R015-D8	1.5	2.0	16	0.15	7.8	D8	50	7.7	○	8mm
TBWR20160R015-D8	2.0	3.0	16	0.15	7.8	D8	50	7.7	○	8mm
TBWR25160R015-D8	2.5	3.0	16	0.15	7.8	D8	50	7.7	○	8mm

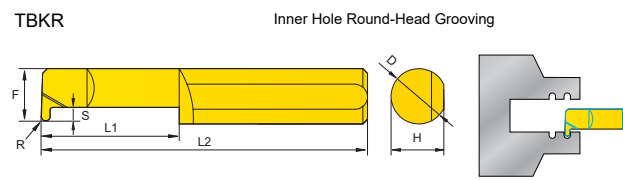

Model	F	S	L1	R	D	L2	H	Stock	Processing Diameter
TBKR40100R050-D4	3.8	1.0	10	0.5	D4	50	3.7	○	4mm
TBKR40100R075-D4	3.8	1.0	10	0.75	D4	50	3.7	○	4mm
TBKR60150R050-D6	5.8	1.5	15	0.5	D6	50	5.7	○	6mm
TBKR60150R075-D6	5.8	1.5	15	0.75	D6	50	5.7	○	6mm
TBKR60150R100-D6	5.8	1.5	15	1.0	D6	50	5.7	○	6mm

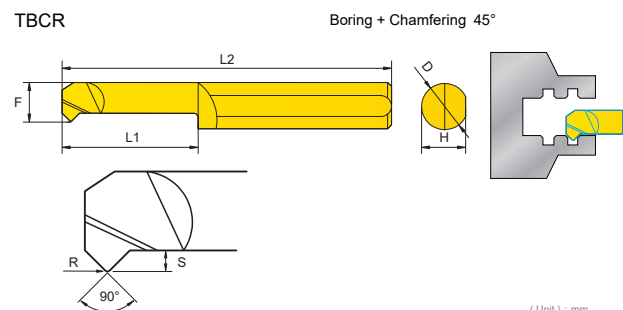

Model	F	L1	S	R	D	L2	H	Stock
TBCR30100R020-D4	2.8	10	0.5	0.2	D4	50	3.7	○
TBCR40150R020-D4	3.7	15	0.8	0.2	D4	50	3.7	○
TBCR50150R020-D5	4.7	15	1.2	0.2	D5	50	4.7	○
TBCR60150R020-D6	5.7	15	1.5	0.2	D6	50	5.7	○

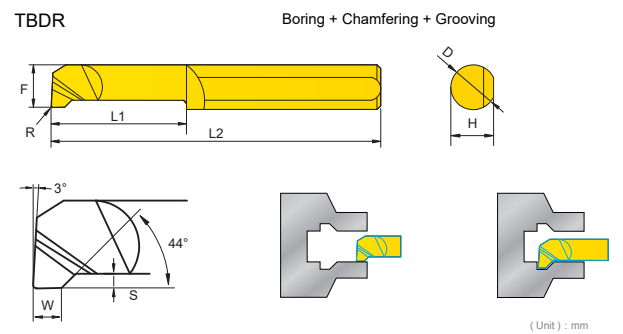

Model	F	L1	S	R	D	L2	H	W	Stock	Processing Diameter
TBDR40100R020-D4	3.8	10.0	0.8	0.2	D4	50	3.7	1.5	○	4mm
TBDR50150R020-D5	4.8	15.0	1.2	0.2	D5	50	4.7	1.5	○	5mm
TBDR60150R020-D6	5.8	15.0	1.4	0.2	D6	50	5.7	1.5	○	6mm

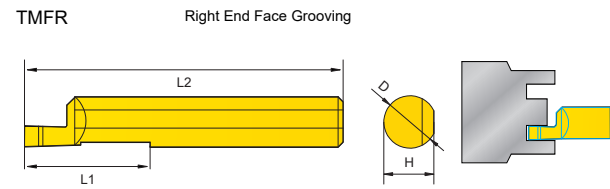

Model	F	L1	T	W	R	D	L2	H	Stock	Processing Diameter
TMFR60150W0.75-D6	2.95	15	1.5	0.75	0.1	D6	50	5.7	○	8.0
TMFR60150W1.0-D6	2.95	15	2.0	1.0	0.1	D6	50	5.7	○	8.0
TMFR60200W2.0-D8	3.95	20	4.0	2.0	0.2	D8	50	7.7	○	10.0
TMFR60200W2.5-D8	3.95	20	5.0	2.5	0.2	D8	50	7.7	○	10.0
TMFR60200W3.0-D8	3.95	20	6.0	3.0	0.2	D8	50	7.7	○	10.0

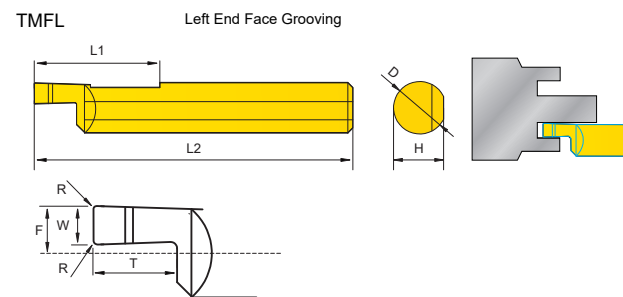

Model	F	L1	T	W	R	D	L2	H	Stock	Processing Diameter
TMFL60150W0.75-D6	2.95	15	1.5	0.75	0.1	D6	50	5.7	○	8.0
TMFL60150W1.0-D6	2.95	15	2.0	1.0	0.1	D6	50	5.7	○	8.0
TMFL60200W2.0-D8	3.95	20	4.0	2.0	0.2	D8	50	7.7	○	10.0
TMFL60200W2.5-D8	3.95	20	5.0	2.5	0.2	D8	50	7.7	○	10.0
TMFL60200W3.0-D8	3.95	20	6.0	3.0	0.2	D8	50	7.7	○	10.0

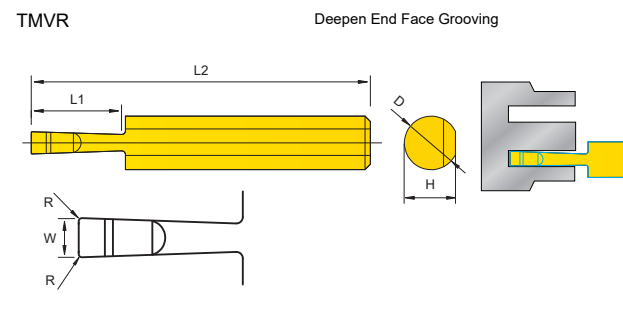

Model	L1	W	R	D	L2	H	Stock	Processing Diameter
TMVR10150W2.0-D10	15	2.0	0.2	D10	50	9	○	15
TMVR10150W3.0-D10	15	3.0	0.2	D10	50	9	○	15
TMVR10150W4.0-D10	15	4.0	0.2	D10	50	9	○	15

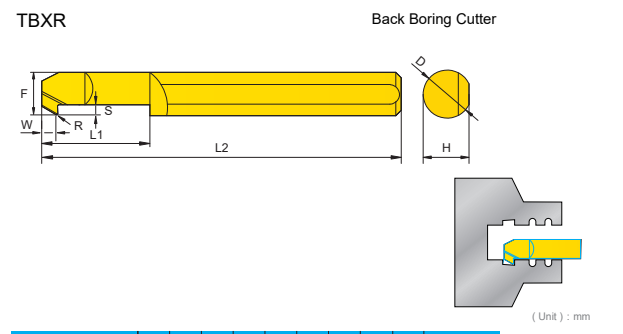

Model	F	W	S	L1	R	D	L2	H	Stock	Processing Diameter
TBXR40100R010-D4	3.8	1.5	1.0	10	0.1	D4	50	3.7	○	4mm
TBXR50150R015-D5	4.8	2.0	1.5	15	0.15	D5	50	4.7	○	5mm
TBXR60200R020-D6	5.8	2.0	2.0	20	0.2	D6	50	5.7	○	6mm

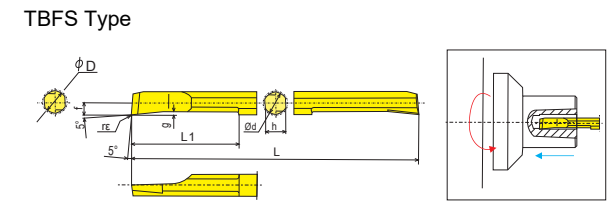

Ordering code	Dimensions									
	(mm) D	φd	L	L1	f	h	g	r	Stock	
TBFS 020R005S	2.2	2	50	10	0.9	1.8	0.25	0.05	○	
030R005S	3.2	3	50	15	1.4	2.7	0.40	0.05	○	
030R015S	3.2	3	50	15	1.4	2.7	0.40	0.15	○	
040R005S	4.2	4	60	20	1.9	3.6	0.45	0.05	○	
040R015S	4.2	4	60	20	1.9	3.6	0.45	0.15	○	
050R005S	5.2	5	70	25	2.4	4.5	0.50	0.05	○	
050R015S	5.2	5	70	25	2.4	4.5	0.50	0.15	○	

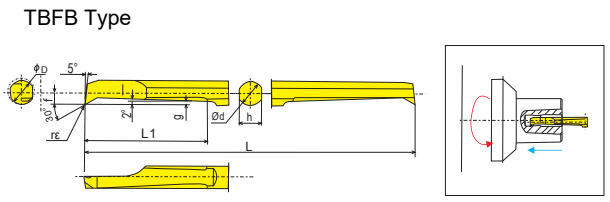

Ordering code	Dimensions									
	(mm) D	φd	L	L1	f	h	g	r	Stock	
TBFB 020R005F	2.2	2	50	10	0.9	1.8	0.25	0.05	○	
030R005F	3.2	3	50	15	1.4	2.7	0.40	0.05	○	
030R015F	3.2	3	50	15	1.4	2.7	0.40	0.15	○	
040R005F	4.2	4	60	20	1.9	3.6	0.45	0.05	○	
040R015F	4.2	4	60	20	1.9	3.6	0.45	0.15	○	
050R005F	5.2	5	70	25	2.4	4.5	0.50	0.05	○	
050R015F	5.2	5	70	25	2.4	4.5	0.50	0.15	○	

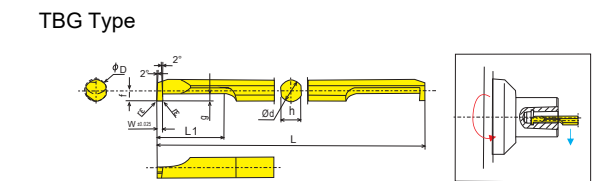

Ordering code	Dimensions									
	(mm) D	W	φd	L1	g	L	f	h	r	Stock
TBG 030050RB	3	0.50								○
030075RB	3	0.75	3	9	0.8	50	1.3	2.7	0.05	○
030100RB	3	1.00								○
040050RB	4	0.50								○
040075RB	4	0.75	4	12	1.0	60	1.8	3.6	0.05	○
040100RB	4	1.00								○
050050RB	5	0.50								○
050100RB	5	1.00	5	20	1.2	70	2.3	4.5	0.05	○
050150RB	5	1.50								○

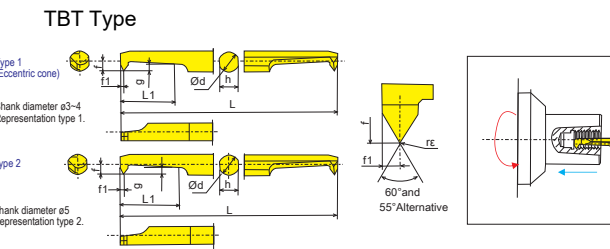

Ordering code	Dimensions										Processable range				Recommended chip			
	(mm) D	φd	L	g	L	f	h	r	Stock	mm	mm	mm	mm	mm	mm	mm	mm	
TBT 030M4RB	3.0	3.0	7.5	0.8	50	1.3	0.5	2.7	0.05	0.05	0.05	0.05	0.05	0.05	0.05	0.05	0.05	
035M5RB	3.5	3.5	9.5	1.0	60	1.8	0.7	3.6	0.05	0.05	0.05	0.05	0.05	0.05	0.05	0.05	0.05	
040M6RB	4.0	4.0	10.5	1.2	80	1.8	0.7	3.6	0.05	0.05	0.05	0.05	0.05	0.05	0.05	0.05	0.05	
050M8RB	5.0	5.0	15.8	1.5	70	2.3	0.8	4.5	0.05	0.05	0.05	0.05	0.05	0.05	0.05	0.05	0.05	

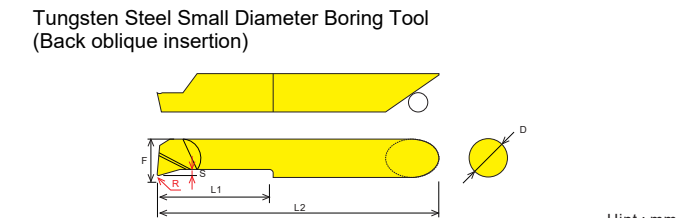

Ordering code	Minimum Machining Diameter	Dimensions						
		F	L1	S	R	H	L2	φD
STBFR 20R005	2.0	1.7	7	0.25	0.05	32.5	4	
25R005	2.5	2.3	8	0.25	0.05	33.5	4	
30R008	3.0	2.75	12	0.4	0.08	37.5	4	
35R010	3.5	3.25	15	0.4	0.1	40	4	
40R010	4.0	3.8	15	0.6	0.1	39.5	4	
50R015	5.0	4.7	25	0.75	0.15	51	5	
60R015	6.0	5.7	30	0.75	0.15	56.5	6	
70R015	7.0	6.7	35	0.8	0.15	60	7	

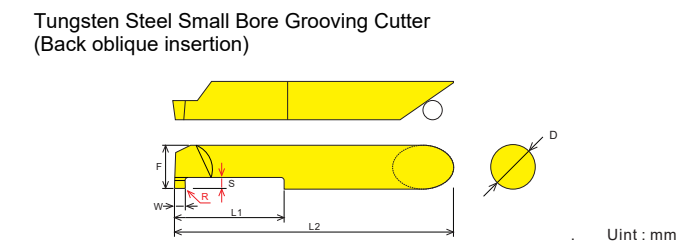

Ordering code	Minimum Machining Diameter	Dimensions							
		F	L1	S	R	H	L2	φD	W
STBWR 0512R005D4	4.0	3.8	12	1.0	0.05	37	4	0.5	
1012R005D4	4.0	3.8	12	1.0	0.05	37	4	1.0	
1512R005D4	4.0	3.8	12	1.0	0.05	37	4	1.5	
1020R010D5	5.0	4.6	20	1.5	0.1	46	5	1.0	
1520R010D5	5.0	4.6	20	1.5	0.1	46	5	1.5	
2020R010D5	5.0	4.6	20	1.5	0.1	46	5	2.0	
1020R015D6	6.0	5.7	20	2.0	0.15	46.5	6	1.0	
1520R015D6	6.0	5.7	20	2.0	0.15	46.5	6	1.5	
2020R015D6	6.0	5.7	20	2.0	0.15	46.5	6	2.0	
1025R015D8	8.0	7.5	25	2.0	0.15	53.5	8	1.0	
1525R015D8	8.0	7.5	25	2.0	0.15	53.5	8	1.5	
2025R015D8	8.0	7.5	25	2.5	0.15	53.5	8	2.0	
2525R015D8	8.0	7.5	25	3.0	0.15	53.5	8	2.5	

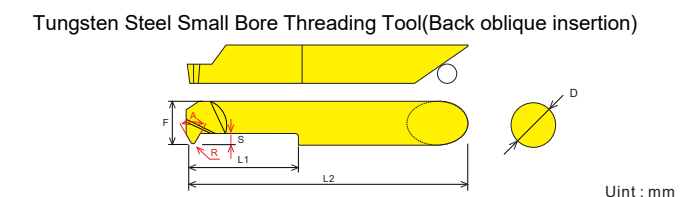

Ordering code	Minimum Machining Diameter	Dimensions							
		F	L1	S	R	H	L2	φD	A
STTIR 3815-A60	M4	3.8	15	1.2	0.05	40	4	60°	
4715-A60	M5	4.7	15	1.5	0.05	40	5	60°	
5920-A60	M6	5.9	20	2.0	0.08	46.5	6	60°	
3815-A55	M4	3.8	15	1.2	0.05	40	4	55°	
4715-A55	M5	4.7	15	1.5	0.05	40	5	55°	
5920-A55	M6	5.9	20	2.0	0.08	46.5	6	55°	

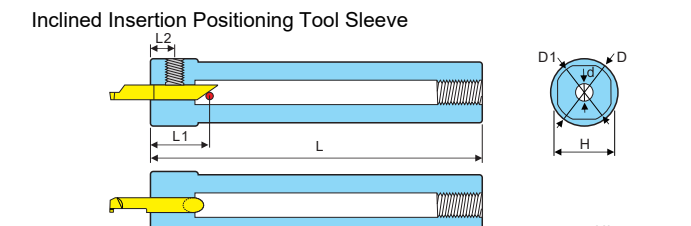

Modular inner hole turning tool

Modular High Hardness And High Rigidity Shank

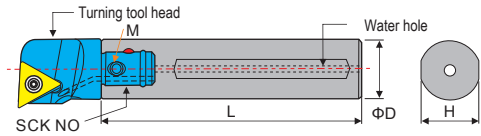

Ordering code	SCK No	Dimensions			Screw	Wrench	Stock
		Min ØD	L	F			
SCK1-Y20-180L	SCK1	20	180	230120	230047	●	
SCK2-Y25-175L	SCK2	25	175	230121	230060	●	
SCK2-Y25-225L	SCK2	25	225	230121	230060	●	
SCK3-Y32-220L	SCK3	32	220	230121	230060	○	
SCK3-Y32-270L	SCK3	32	270	230121	230060	○	
SCK4-Y40-267L	SCK4	40	267	230122	230061	○	
SCK5-Y50-300L	SCK5	50	300	230123	230062	○	

STUP Modular Vehicle Head

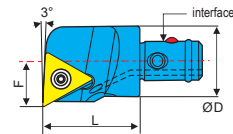

Ordering code	INSERT	Dimensions			Screw	Wrench	Stock	
		Min ØD	L	F				
SCK1-A20-STUPR11-22	TP1103	22	20	22	11.5	230078	230055	●
SCK2-A25-STUPR11-30		30	25	25	15			●
SCK1-A20-STUPR1603-25		25	20	22	13			●
SCK2-A25-STUPR1603-28		28	25	27	14			●
SCK3-A32-STUPR1603-38	TP1603	38	32	30	7.5	230090	230057	○
SCK4-A40-STUPR1603-50		50	40	33	21.5			○
SCK5-A50-STUPR1603-60		60	50	35	26.5			○
SCK1-A20-STUPR16T3-25		25	20	22	13			●
SCK2-A25-STUPR16T3-28		28	25	27	14			●
SCK3-A32-STUPR16T3-38	TP16T3	38	32	30	17.5	230090	230057	○
SCK4-A40-STUPR16T3-50		50	40	33	21.5			○
SCK5-A50-STUPR16T3-60		60	50	35	26.5			○
SCK1-A20-STUPR1604-25		25	20	22	13			●
SCK2-A25-STUPR1604-28		28	25	27	14			●
SCK3-A32-STUPR1604-38	TP1604	38	32	30	17.5	230090	230057	○
SCK4-A40-STUPR1604-50		50	40	33	21.5			○
SCK5-A50-STUPR1604-60		60	50	35	26.5			○

STUC Modular Vehicle Head

Ordering code	INSERT	Dimensions			Screw	Wrench	Stock	
		Min ØD	L	F				
SCK1-A20-STUCR11-22	TC1103	22	20	22	11	230074	230054	●
SCK2-A25-STUCR11-28		28	25	25	14			●
SCK1-A20-STUPR16-22		22	20	22	11			●
SCK2-A25-STUPR16-28		28	25	27	14			●
SCK3-A32-STUPR16-38	TC16T3	38	32	30	17.5	230090	230057	○
SCK4-A40-STUPR16-50		50	40	33	21.5			○
SCK5-A50-STUPR16-60		60	50	35	26.5			○

SCLC modular vehicle head

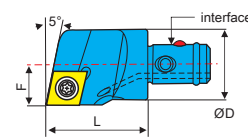

Ordering code	INSERT	Dimensions			Screw	Wrench	Stock	
		Min ØD	L	F				
SCK1-A20-SCLCR09-22		22	20	22	11			●
SCK2-A25-SCLCR09-28		28	25	25	14.5			●
SCK3-A32-SCLCR09-38	CC09T3	38	32	30	17.5	230090	230057	○
SCK4-A40-SCLCR09-50		50	40	33	21			○
SCK5-A50-SCLCR09-60		60	50	35	30			○

SCKC Modular Vehicle Head

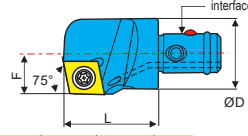

Ordering code	INSERT	Dimensions			Screw	Wrench	Stock	
		Min ØD	L	F				
SCK1-A20-SCKCR09-22	CC09T3	22	20	22	11	230090	230057	●
SCK2-A25-SCKCR09-30		30	25	25	15			○
SCK3-A32-SCKCR09-38		38	32	30	17.5			○

Modular Tungsten Steel Tool Holder

Ordering code	SCK No	Dimensions		Screw	Wrench	Stock
		ØD	L			
SCK1-E20-180L	SCK1	20	180	230120	230047	●
SCK1-E20-230L	SCK1	20	230	230120	230047	●
SCK2-E25-175L	SCK2	25	175	230121	230060	●
SCK2-E25-225L	SCK2	25	225	230121	230060	●
SCK3-E32-170L	SCK3	32	170	230121	230060	○
SCK3-E32-220L	SCK3	32	220	230121	230060	○
SCK3-E32-270L	SCK3	32	270	230121	230060	○
SCK4-E40-267L	SCK4	40	267	230122	230061	○
SCK5-E50-300L	SCK5	50	300	230123	230062	○

SVJC Type Modular Cutter Head

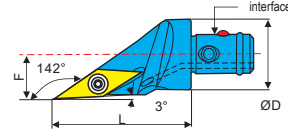

Ordering code	INSERT	Dimensions			Screw	Wrench	Stock	
		Min ØD	L	F				
SCK1-A20-SVJCR11-22	VC1103	22	20	19	11	230074	230054	●
SCK1-A20-SVJCR16-22		22	20	33	11			●
SCK2-A25-SVJCR16-28	VC1604	28	25	35	14	230082	230057	○
SCK3-A32-SVJCR16-35		35	32	39	17.5			○

SVUC Type Modular Cutter Head

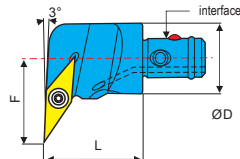

Ordering code	INSERT	Dimensions			Screw	Wrench	Stock	
		Min ØD	L	F				
SCK1-A20-SVUCR11-27	VC1103	27	20	22	15	230074	230054	●
SCK2-A25-SVUCR11-30		30	25	25	17			●
SCK1-A20-SVUCR16-31		31	20	27	19			○
SCK2-A25-SVUCR16-33	VC1604	33	25	27	18	230084	230057	○
SCK3-A32-SVUCR16-40		40	32	30	22			○
SCK4-A40-SVUCR16-50		50	40	33	27			○

SDQC Modular Car Cutter Head

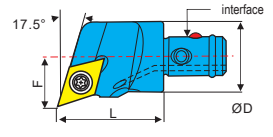

Ordering code	INSERT	Dimensions			Screw	Wrench	Stock	
		Min ØD	L	F				
SCK1-A20-SDQCR11-25		25	20	22	13			●
SCK2-A25-SDQCR11-32		32	25	27	17			●
SCK3-A32-SDQCR11-40	DC11T3	40	32	30	20	230090	230057	○
SCK4-A40-SDQCR11-50		50	40	33	25			○
SCK5-A50-SDQCR11-60		60	50	35	30			○

SDUC Type Modular Car Cutter Head

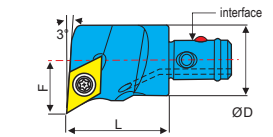

Ordering code	INSERT	Dimensions			Screw	Wrench	Stock	
		Min ØD	L	F				
SCK1-A20-SDUCR11-23		23	20	22	12.5			●
SCK1-A20-SDUCR11-25		25	20	22	13			●
SCK2-A25-SDUCR11-32	DC11T3	32	25	25	17	230090	230057	○
SCK3-A32-SDUCR11-40		40	32	30	20			○
SCK4-A40-SDUCR11-50		50	40	33	25			○
SCK5-A50-SDUCR11-60		60	50	35	30			○

SDZC Modular Car Cutter Head

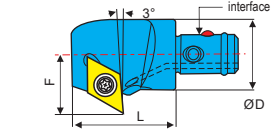

Ordering code	INSERT	R寸			Screw	Wrench	Stock	
		Min ØD	L	F				
SCK1-A20-SDZCR11-26		26	20	29	15.5			●
SCK2-A25-SDZCR11-33	DC11T3	33	25	34	18	230090	230057	○
SCK3-A32-SDZCR11-40		40	32	35	21.5			○

MGI V Modularized Cutter Head

Ordering code	INSERT	Dimensions			Screw	Wrench	Stock	
		Min ØD	L	F				
SCK1-A20-MGIVR25-2	MGMN2	25	20	24	14.1			○
SCK1-A20-MGIVR25-3		3	25	20	24	14.1		○
SCK1-A20-MGIVR25-4		4	25	20	24	14.1		○
SCK2-A25-MGIVR30-2	MGMN2	30	25	25	16.6	230101	230057	○
SCK2-A25-MGIVR32-3		3	32	25	18.6			○
SCK2-A25-MGIVR32-4		4	32	25	18.6			○

MTUN Type

Ordering code	Dimensions			INSERT	Shim	Pin	Clamp	Screw	Wrench	Stock	
	Min ØD	L	F								
SCK1-A20-MTUNR16-25	25	20	29	13						●	
SCK2-A25-MTUNR16-32	32	25	30	17						●	
SCK3-A32-MTUNR16-40	40	32	34	20	TN1604	230001	230129	230115	230047	230048	○
SCK4-A40-MTUNR16-50	50	40	35	26						○	
SCK5-A50-MTUNR16-60	60	50	36	31						○	

MCLN Type

Ordering code	Dimensions			INSERT	Shim	Pin	Clamp	Screw	Wrench	Stock	
	Min ØD	L	F								
SCK1-A20-MCLNR12-25	25	20	33	13						●	
SCK2-A25-MCLNR12-32	32	25	34	15						●	
SCK3-A32-MCLNR12-40	40	32	35	20	CN1204	230001	230129	230115	230047	230048	○
SCK4-A40-MCLNR12-50	50	40	35	25						○	
SCK5-A50-MCLNR12-63	63	50	36	30						○	

S..MW..Double-headed outer circle and inner hole common turning tool holder

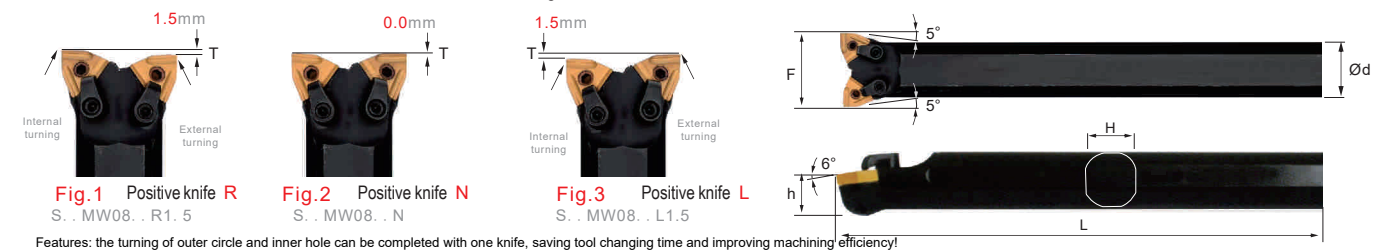

Features: the turning of outer circle and inner hole can be completed with one knife, saving tool changing time and improving machining efficiency!

Ordering code	Dimensions							Insert	Shim	Pin	Clamp	Screw	Wrench	Fig.
	ØD _{min}	Ød	L	H	h	F	T							
S25R-MW08-R1.5	41	25	200	24	15	33	1.5							Fig.1
S32S-MW08-R1.5	49	32	250	30	20	38	1.5	WN..0804..	230031	230007	230131	230116	230048	
S40S-MW08-R1.5	56	40	250	38	25	45	1.5							
S25R-MW08-N	41	25	200	24	15	33	0							Fig.2
S32S-MW08-N	49	32	250	30	20	38	0	WN..0804..	230031	230007	230131	230116	230048	
S40S-MW08-N	56</													

M | D | E | P Type Internal Turning Tool

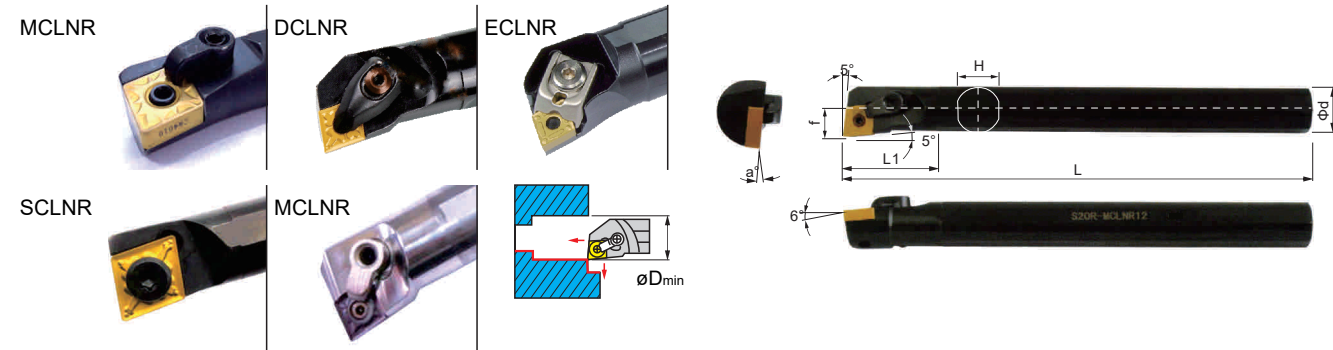

R-Type

Ordering code	Dimensions							Insert	Shim	Pin	Clamp	Screw	Wrench	Stock	
	ϕD_{min}	ϕd	L	L1	H	f	α°							R	L
S16Q-MCLNR/L12	20	16	180	35	15	11	18°	CN..1204..	/	230006	230129	230115	230047 230048	•	•
S20R-MCLNR/L12	25	20	200	45	19	13	15°							•	•
S25S-MCLNR/L12	29	25	250	45	25	15	12°							•	•
S32T-MCLNR/L12	38	32	300	50	30	20.5	17°							•	•
S40T-MCLNR/L12	44	40	300	55	38	24	15°							•	•
S50U-MCLNR/L12	60	50	350	55	48	31	12°							•	•
S32T-MCLNR/L16	40	32	300	60	30	22.5	17°							•	•
S40T-MCLNR/L16	48	40	300	60	38	26	15°							•	•
S50U-MCLNR/L16	60	50	350	60	48	31	12°							•	•
S60V-MCLNR/L16	70	60	400	60	58	36	10°							•	•
S40T-MCLNR/L19	50	40	300	70	38	26	15°	○	○						
S50U-MCLNR/L19	60	50	350	70	48	31	12°	•	•						
S60V-MCLNR/L19	70	60	400	70	58	36	10°	○	○						

Ordering code	Dimensions							Insert	Shim	Shim Screw	Clamp	Screw	Wrench	Stock	
	ϕD_{min}	ϕd	L	L1	H	f	α°							R	L
S20R-DCLNR/L12	25	20	200	45	19	13	15°	CN..1204..	/	/	230136	230108	230048	○	○
S25S-DCLNR/L12	29	25	250	45	24	15	12°							○	○
S32T-DCLNR/L12	38	32	300	50	30	20.5	17°							○	○
S40T-DCLNR/L12	44	40	300	55	38	24	15°							○	○

Ordering code	Dimensions							Insert	Shim	Pin	Clamp	Screw	Wrench	Stock	
	ϕD_{min}	ϕd	L	L1	H	f	α°							R	L
S32T-ECLNR/L12	40	32	300	50	30	22.5	17°	CN..1204..	230018	230015	230141	230112	230048 230049	○	○
S40T-ECLNR/L12	48	40	300	55	38	26	15°							○	○

Ordering code	Dimensions							Insert	Screw	Wrench	Stock	
	ϕD_{min}	ϕd	f	L	L1	H	α°				R	L
S16Q-SCLNR/L12	19	16	9.5	180	26	14.8	15°	CN..1204..	230099	230058	•	•
S18Q-SCLNR/L12	21	18	10.5	180	28	16.8	15°				•	•
S20R-SCLNR/L12	23	20	11.5	200	28	18.4	15°				•	•

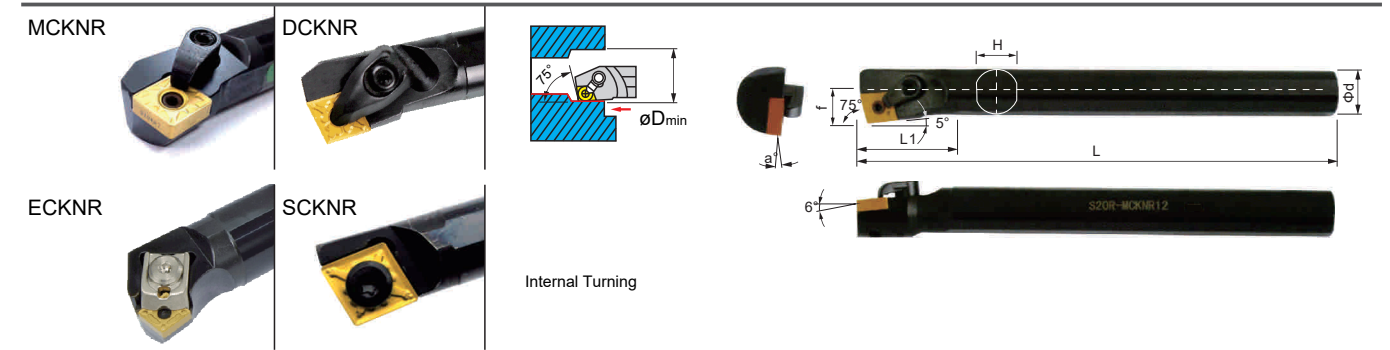

R-Type

Ordering code	Dimensions							Insert	Shim	Pin	Clamp	Screw	Wrench	Stock	
	ϕD_{min}	ϕd	L	L1	H	f	α°							R	L
S20R-MCKNR/L12	25	20	200	45	19	13	15°	CN..1204..	/	230006	230129	230115	230047 230048	•	•
S25S-MCKNR/L12	30	25	250	45	24	15.5	12°							•	•
S32T-MCKNR/L12	38	32	300	50	30	20.5	17°							•	•
S40T-MCKNR/L12	46	40	300	55	38	24	15°							•	•
S50U-MCKNR/L12	60	50	350	70	48	35	12°							•	•
S20R-DCKNR/L12	25	20	200	45	19	13	15°							CN..1204..	/
S25S-DCKNR/L12	30	25	250	45	24	15.5	12°	○	○						
S32T-DCKNR/L12	38	32	300	50	30	20.5	17°	○	○						
S40T-DCKNR/L12	46	40	300	55	38	24	15°	○	○						

Ordering code	Dimensions							Insert	Shim	Shim Screw	Clamp	Screw	Wrench	Stock	
	ϕD_{min}	ϕd	L	L1	H	f	α°							R	L
S32T-ECKNR/L12	38	32	300	50	30	20.5	17°	CN..1204..	230018	230015	230143	230112	230048 230049	○	○
S40T-ECKNR/L12	46	40	300	55	38	24	15°							○	○

Ordering code	Dimensions							Insert	Screw	Wrench	Stock	
	ϕD_{min}	ϕd	f	L	L1	H	α°				R	L
S16Q-SCKNR/L12	19	16	9.5	180	26	14.8	15°	CN..1204..	230099	230058	•	•
S18Q-SCKNR/L12	20	18	10.5	180	28	16.8	15°				•	•
S20R-SCKNR/L12	23	20	11.5	200	28	18.4	15°				•	•

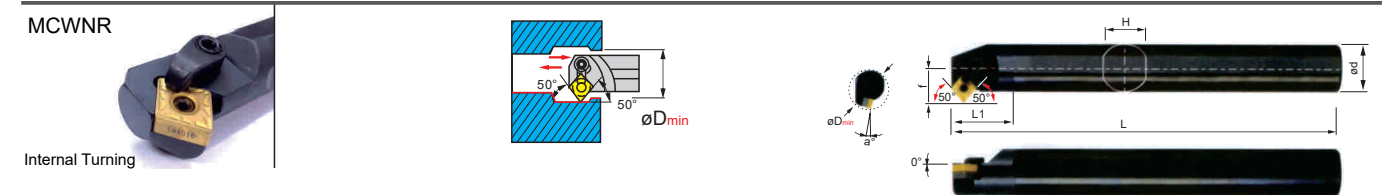

R-Type

Ordering code	Dimensions							Insert	Shim	Pin	Clamp	Screw	Wrench	Stock	
	ϕD_{min}	ϕd	L	L1	H	f	α°							R	L
S20R-MCWNR/L12	30	20	200	45	19	17	15°	CN..1204..	/	230006	230129	230115	230047 230048	•	•
S25S-MCWNR/L12	35	25	250	45	24	19.5	12°							•	•
S32T-MCWNR/L12	42	32	300	50	30	23.5	17°							•	•
S40T-MCWNR/L12	50	40	300	55	38	27	15°							•	•

Ordering code	Dimensions							Insert	Shim	Shim Screw	Clamp	Screw	Wrench	Stock	
	ϕD_{min}	ϕd	L	L1	H	f	α°							R	L
S20R-DCWNR/L12	30	20	200	45	19	17	15°	CN..1204..	/	/	230136	230108	230048	○	○
S25S-DCWNR/L12	35	25	250	45	24	19.5	12°							○	○
S32T-DCWNR/L12	42	32	300	50	30	23.5	17°							○	○
S40T-DCWNR/L12	50	40	300	55	38	27	15°							○	○

M | D | E | P Type Internal Turning Tool

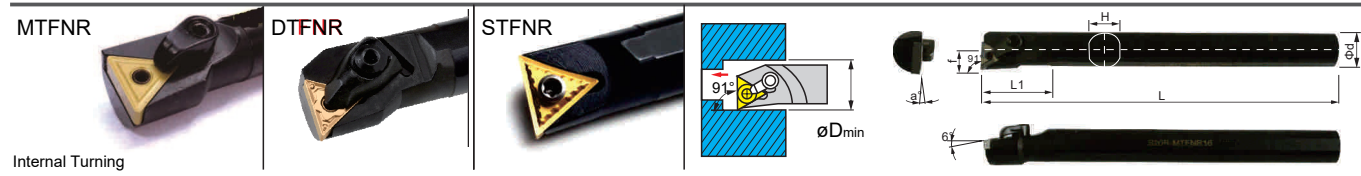

Ordering code	Dimensions							Insert	Shim	Pin	Clamp	Screw	Wrench	Stock	
	ϕD_{min}	ϕd	L	L1	H	f	α°							R	L
S16Q-MTFNR/L16	20	16	180	35	15	11	18°	TN..1604..	/	230001	230129	230115	230047 230048	•	•
S18Q-MTFNR/L16	22	18	180	35	17	12	15°							•	•
S20R-MTFNR/L16	25	20	200	40	19	13	15°							•	•
S25S-MTFNR/L16	30	25	250	45	24	15.5	12°							•	•
S32T-MTFNR/L16	38	32	300	54	30	20.5	17°							•	•
S40T-MTFNR/L16	47	40	300	60	38	25	15°							•	•

Ordering code	Dimensions							Insert	Shim	Shim Screw	Clamp	Screw	Wrench	Stock	
	ϕD_{min}	ϕd	L	L1	H	f	α°							R	L
S16Q-DTFNR/L16	20	16	180	35	15	11	18°	TN..1604..	/	/	230138	230108	230048	○	○
S18Q-DTFNR/L16	22	18	180	35	17	12	15°							○	○
S20R-DTFNR/L16	25	20	200	40	19	13	15°							○	○
S25S-DTFNR/L16	30	25	250	45	24	15.5	12°							○	○
S32T-DTFNR/L16	38	32	300	54	30	20.5	17°							○	○
S40T-DTFNR/L16	47	40	300	60	38	25	15°							○	○

Ordering code	Dimensions							Insert	Screw	Wrench	Stock	
	ϕD_{min}	ϕd	f	L	L1	H	α°				R	L
S16Q-STFNR/L16	18	16	9	180	26	14.8	15°	TN..1604..	230088	230057	•	•
S18Q-STFNR/L16	21	18	10	180	28	16.8	15°				•	•
S20R-STFNR/L16	22	20	11	200	28	18.4	15°				•	•

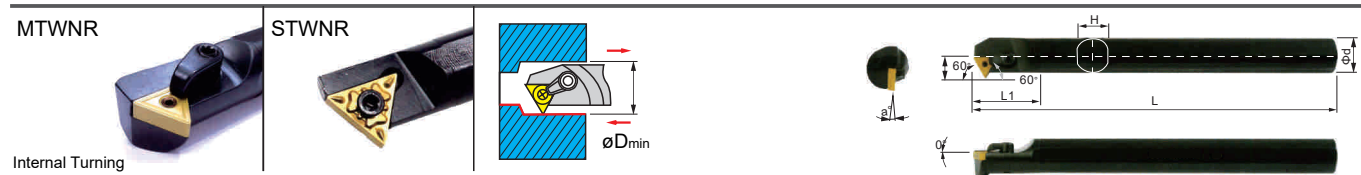

Ordering code	Dimensions							Insert	Shim	Pin	Clamp	Screw	Wrench	Stock	
	ϕD_{min}	ϕd	L	L1	H	f	α°							R	L
S20R-MTWNR/L16	27	20	200	40	19	14	15°	TN..1604..	/	230001	230129	230115	230047 230048	•	•
S25S-MTWNR/L16	32	25	250	45	24	16.5	12°							•	•
S32T-MTWNR/L16	39	32	300	54	30	20	17°							•	•

Ordering code	Dimensions							Insert	Shim	Shim Screw	Clamp	Screw	Wrench	Stock	
	ϕD_{min}	ϕd	L	L1	H	f	α°							R	L
S20R-DTWNR/L16	27	20	200	40	19	14	15°	TN..1604..	/	/	230138	230108	230048	○	○
S25S-DTWNR/L16	32	25	250	45	24	16.5	12°							○	○
S32T-DTWNR/L16	39	32	300	54	30	20	17°							○	○

Ordering code	Dimensions							Insert	Screw	Wrench	Stock	
	ϕD_{min}	ϕd	f	L	L1	H	α°				R	L
S16Q-STWNR/L16	21	16	11.5	180	26	14.8	15°	TN..1604..	230088	230057	•	•
S18Q-STWNR/L16	23	18	12.5	180	28	16.8	15°				•	•
S20R-STWNR/L16	25	20	13.5	200	28	18.4	15°				•	•

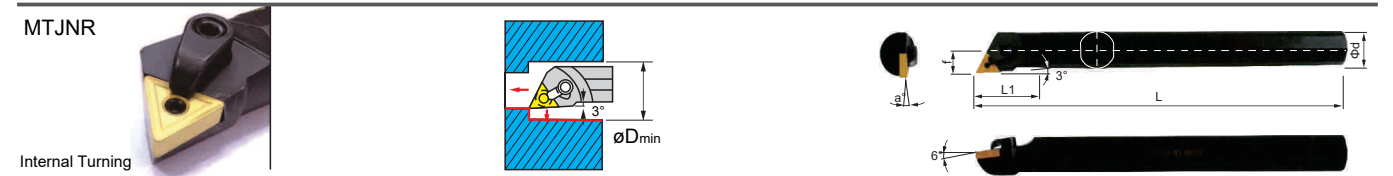

Ordering code	Dimensions							Insert	Shim	Pin	Clamp	Screw	Wrench	Stock	
	ϕD_{min}	ϕd	L	L1	H	f	α°							R	L
S20R-MTJNR/L16	25	20	200	40	19	12.5	15°	TN..1604..	/	230001	230129	230115	230047 230048	•	•
S25S-MTJNR/L16	32	25	250	45	24	16	12°							•	•
S32T-MTJNR/L16	41	32	300	54	30	22.5	17°							•	•
S40U-MTJNR/L16	50	40	350	55	38	27	15°							•	•

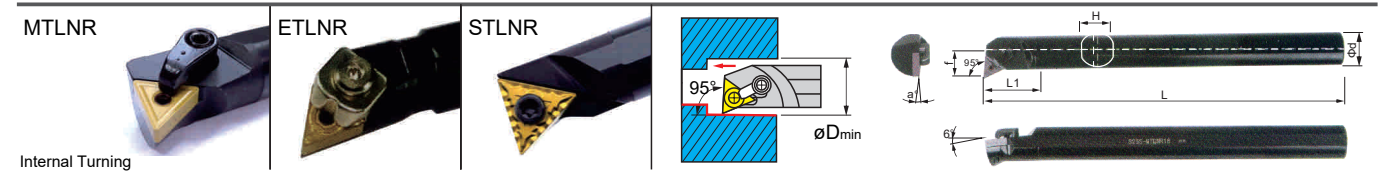

Ordering code	Dimensions							Insert	Shim	Pin	Clamp	Screw	Wrench	Stock	
	ϕD_{min}	ϕd	L	L1	H	f	α°							R	L
S18Q-MTLNR/L16	22	18	180	36	17	12.5	15°	TN..1604..	/	230001	230129	230115	230046 230048	•	•
S20R-MTLNR/L16	25	20	200	37	19	13.5	15°							•	•
S25S-MTLNR/L16	30	25	250	45	23	17	12°							•	○
S32T-MTLNR/L16	40	32	300	50	30	22.5	17°							•	○

Ordering code	Dimensions							Insert	Shim	Pin	Clamp	Screw	Wrench	Stock	
	ϕD_{min}	ϕd	L	L1	H	f	α°							R	L
S20R-ETLNR/L16	25	20	200	40	13	13.5	15°	TN..1604..	/	230002	230145	230112	230047 230049	•	•
S25S-ETLNR/L16	31	25	250	45	24	17	12°							•	•
S32T-ETLNR/L16	41	32	300	54	30	22.5	12°							•	•
S40T-ETLNR/L16	50	40	300	60	38	26.5	10°							•	•

Ordering code	Dimensions							Insert	Screw	Wrench	Stock	
	ϕD_{min}	ϕd	f	L	L1	H	α°				R	L
S16Q-STLNR/L16	21	16	11.5	180	26	14.8	15°	TN..1604..	230088	230057	•	•
S18Q-STLNR/L16	23	18	12.5	180	28	16.8	15°				•	•
S20R-STLNR/L16	25	20	13.5	200	28	18.4	15°				•	•

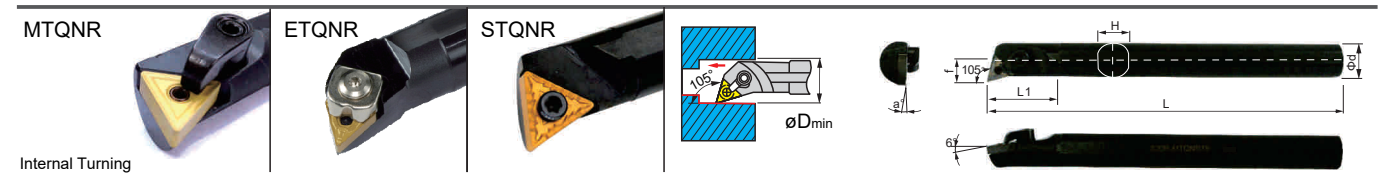

Ordering code	Dimensions							Insert	Shim	Pin	Clamp	Screw	Wrench	Stock	
	ϕD_{min}	ϕd	L	L1	H	f	α°							R	L
S20R-MTQNR/L16	25	20	200	40	13	13.5	15°	TN..1604..	/	230001	230129	230115	230047 230048	•	•
S25S-MTQNR/L16	31	25	250	45	24	17	12°							•	•
S32T-MTQNR/L16	41	32	300	54	30	22.5	17°							•	•
S40T-MTQNR/L16	50	40	300	60	38	26.5	15°							•	•

Ordering code	Dimensions							Insert	Shim	Pin	Clamp	Screw	Wrench	Stock	
	ϕD_{min}	ϕd	L	L1	H	f	α°							R	L
S20R-ETQNR/L16	25	20	200	40	13	13.5	15°	TN..1604..	/	230002	230145	230112	230047 230049	•	•
S25S-ETQNR/L16	31	25	250	45	24	17	12°							•	•
S32T-ETQNR/L16	41	32	300	54	30	22.5	12°							•	•
S40T-ETQNR/L16	50	40	300	60	38	26.5	10°							•	•

Ordering code	Dimensions							Insert	Screw	Wrench	Stock	
	ϕD_{min}	ϕd	f	L	L1	H	α°				R	L
S16Q-STQNR/L16	21	16	11.5	180	26	14.8	15°	TN..1604..	230088	230057	•	•
S18Q-STQNR/L16	23	18	12.5	180	28	16.8	15°				•	•
S20R-STQNR/L16	25	20	13.5	200	28	18.4	15°				•	•

M | D | E | P Type Internal Turning Tool

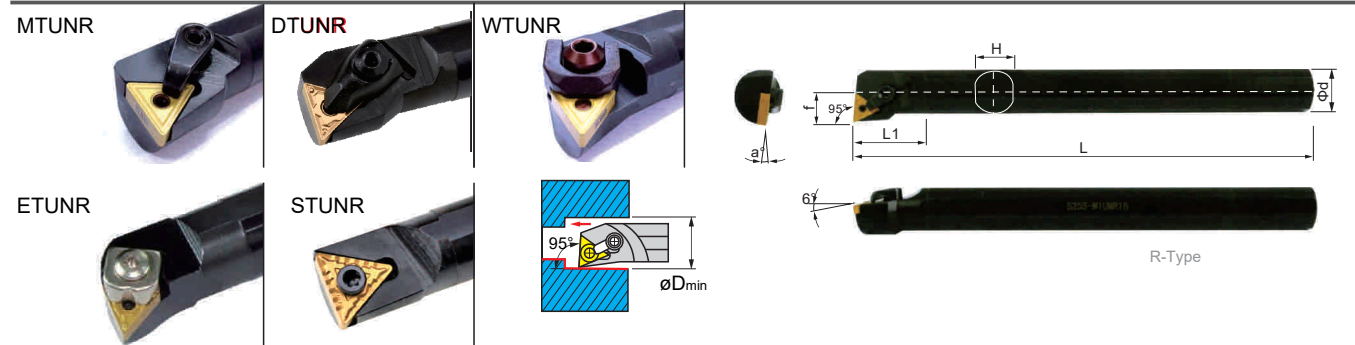

Carbide Steel Shock-Proof Toolholder(Shock-Proof Effect > 8 Times Toolholder Diameter)

Ordering code	Dimensions							Insert	Shim	Pin	Clamp	Screw	Wrench	Stock	
	øD _{min}	ød	L	L1	H	f	α°							R	L
S16Q-MTUNR/L16	22	16	180	35	15	11	18°	TN..1604..	/	230001	230129	230115	230047 230048	•	•
S20R-MTUNR/L16	25	20	200	40	19	13.5	15°							•	•
S25S-MTUNR/L16	31	25	250	45	24	17	12°							•	•
S32T-MTUNR/L16	41	32	300	54	30	22.5	17°							•	•
S40T-MTUNR/L16	50	40	300	60	38	26.5	15°							•	•
S50U-MTUNR/L16	60	50	350	65	48	31	12°							•	•
S60V-MTUNR/L16	70	60	400	70	58	36	10°	•	•						
S40T-MTUNR/L22	50	40	300	60	38	26.5	15°	TN..2204..	230028	230007	230132	230117	230047 230049	•	•
S50U-MTUNR/L22	60	50	350	65	48	31	12°							•	•
S60V-MTUNR/L22	70	60	400	70	58	36	10°							•	•
C20R-MTUNR/L16-25	25	20	200	-	13	13	15°	TN..1604..	/	230001	230129	230115	230047 230048	•	•
C20S-MTUNR/L16-25	25	20	250	-	13	13	15°							•	•
C25R-MTUNR/L16-32	32	25	200	-	24	17	12°							•	•
C25S-MTUNR/L16-32	32	25	250	-	24	17	12°							•	•
C32S-MTUNR/L16-40	40	32	250	-	30	20	17°							•	•
C40S-MTUNR/L16-50	50	40	250	-	38	26	15°							•	•
C50S-MTUNR/L16-60	60	50	250	-	48	31	12°	•	•						

Ordering code	Dimensions							Insert	Shim	Shim Screw	Clamp	Screw	Wrench	Stock	
	øD _{min}	ød	L	L1	H	f	α°							R	L
S16Q-DTUNR/L16	20	16	180	35	15	11	18°	TN..1604..	/	/	/	/	/	•	•
S18Q-DTUNR/L16	22	18	180	35	17	12	15°							•	•
S20R-DTUNR/L16	25	20	200	40	19	13	15°							•	•
S25S-DTUNR/L16	30	25	250	45	24	15.5	12°							•	•
S32T-DTUNR/L16	38	32	300	54	30	20.5	17°							•	•
S40T-DTUNR/L16	47	40	300	60	38	25	15°							•	•
S32T-DTUNR/L16	38	32	300	54	30	20.5	17°	230027	230013	230138	230108	230048	230047 230049	•	•

Ordering code	Dimensions							Insert	Shim	Pin	Clamp	Screw	Wrench	Stock	
	øD _{min}	ød	L	L1	H	f	α°							R	L
S25S-WTUNR/L16	32	25	250	36	23	17	12°	TN..1604..	/	/	/	/	/	•	•
S32T-WTUNR/L16	40	32	300	46	30	22.5	17°							•	•
S40U-WTUNR/L16	45	40	350	56	38	26.5	15°							•	•
S50W-WTUNR/L16	55	50	450	66	48	29.5	15°							•	•

Ordering code	Dimensions							Insert	Shim	Pin	Clamp	Screw	Wrench	Stock		
	øD _{min}	ød	L	L1	H	f	α°							R	L	
S25S-ETUNR/L16	32	25	250	45	24	17	12°	TN..1604..	/	230002	/	/	/	/	•	•
S32T-ETUNR/L16	40	32	300	50	30	22	10°								•	•
S40T-ETUNR/L16	50	40	300	55	38	27	10°								•	•
S50U-ETUNR/L16	60	50	350	60	48	35	8°								•	•

Ordering code	Dimensions							Insert	Screw	Wrench	Stock	
	øD _{min}	ød	f	L	L1	H	α°				R	L
S16Q-STUNR/L16	19	16	9	180	26	NQKU	15°	TN..1604..	230088	230057	•	•
S18Q-STUNR/L16	20	18	10	180	28	NSKU	15°				•	•
S20R-STUNR/L16	22	20	11	200	28	NUKU	15°				•	•

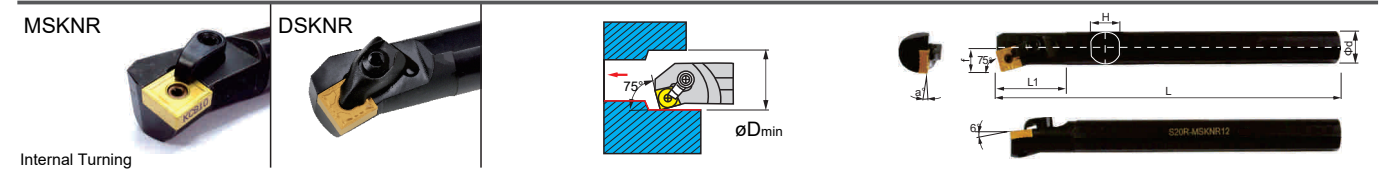

Ordering code	Dimensions							Insert	Shim	Pin	Clamp	Screw	Wrench	Stock	
	øD _{min}	ød	L	L1	H	f	α°							R	L
S20R-MSKNR/L12	26	20	200	40	19	14	15°	SN..1204..	/	230006	230129	230115	230047 230048	•	•
S25S-MSKNR/L12	30	25	250	45	24	16.1	12°							•	•
S32T-MSKNR/L12	40	32	300	50	30	22	17°							•	•
S40T-MSKNR/L12	48	40	300	55	38	27	15°							•	•
S50U-MSKNR/L12	60	50	350	65	48	30	12°							•	•

Ordering code	Dimensions							Insert	Shim	Shim Screw	Clamp	Screw	Wrench	Stock	
	øD _{min}	ød	L	L1	H	f	α°							R	L
S20R-DSKNR/L12	26	20	200	40	19	14	15°	SN..1204..	/	/	/	/	/	•	•
S25S-DSKNR/L12	30	25	250	45	24	16.1	12°							•	•
S32T-DSKNR/L12	40	32	300	50	30	22	17°							•	•
S40T-DSKNR/L12	48	40	300	55	38	27	15°							•	•
S50U-DSKNR/L12	60	50	350	65	48	30	12°							•	•

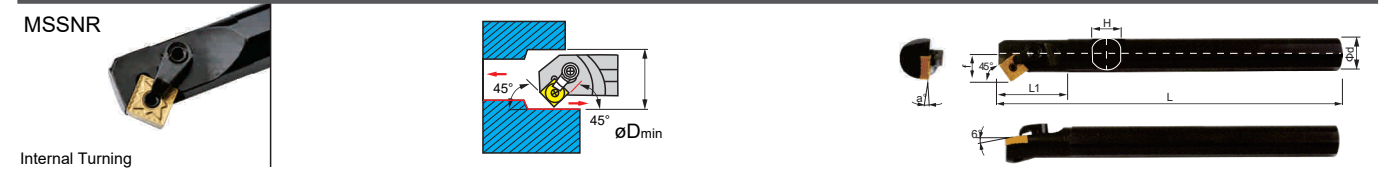

Ordering code	Dimensions							Insert	Shim	Pin	Clamp	Screw	Wrench	Stock	
	øD _{min}	ød	L	L1	H	f	α°							R	L
S20R-MSSNR/L12	27	20	200	35	19	15	15°	SN..1204..	/	230006	230129	230115	230047 230048	•	•
S25S-MSSNR/L12	30	25	250	40	24	17	12°							•	•
S32T-MSSNR/L12	38	32	300	45	30	21	17°							•	•
S40T-MSSNR/L12	46	40	300	50	38	27	15°							•	•
S50U-MSSNR/L12	58	50	350	60	48	30	12°							•	•

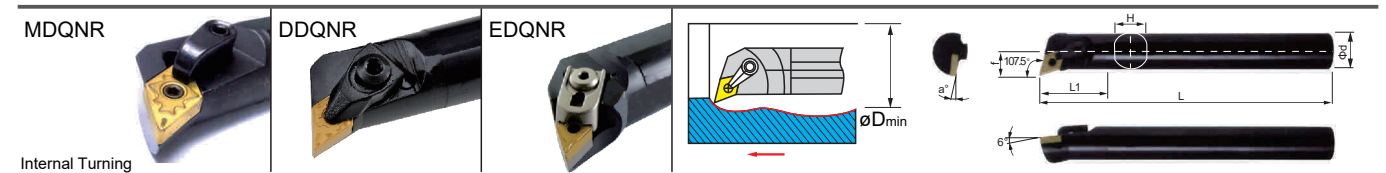

Ordering code	Dimensions							Insert	Shim	Pin	Clamp	Screw	Wrench	Stock	
	øD _{min}	ød	L	L1	H	f	α°							R	L
S20R-MDQNR/L11	25	20	200	40	19	14.5	15°	DN..1104..	/	230001	230129	230116	230046/30	•	•
S25S-MDQNR/L15	31	25	250	45	24	17	12°							•	•
S32T-MDQNR/L15	38	32	300	50	30	20.5	17°							•	•
S40T-MDQNR/L15	50	40	300	60	38	27	15°							•	•

Ordering code	Dimensions							Insert	Shim	Shim Screw	Clamp	Screw	Wrench	Stock	
	øD _{min}	ød	L	L1	H	f	α°							R	L
S20R-DDQNR/L11	25	20	200	40	19	14.5	15°	DN..1104..	/	/	/	/	/	•	•
S25S-DDQNR/L15	31	25	250	45	24	17	12°							•	•
S32T-DDQNR/L15	38	32	300	50	30	20.5	17°							•	•
S40T-DDQNR/L15	50	40	300	60	38	27	15°							•	•

Ordering code	Dimensions							Insert	Shim	Pin	Clamp	Screw	Wrench	Stock	
	øD _{min}	ød	L	L1	H	f	α°							R	L
S32T-EDQNR/L15	40	32	300	50	30	22	10°	DN..1504..	230023	230015	230142	230112	230048 230049	•	•
S40T-EDQNR/L15	50	40	300	60	38	27	10°							•	•

M | D | E | P Type Internal Turning Tool

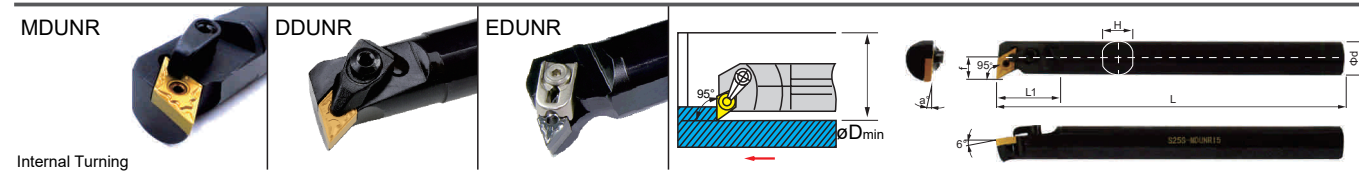

Ordering code	Dimensions							Insert	Shim	Pin	Clamp	Screw	Wrench	Stock	
	ϕD_{min}	ϕd	L	L1	H	f	α°							R	L
S20R-MDUNR/L11	26	20	200	40	19	14.5	15°	DN..1104.. DN..1504.. DN..1506..		230001	230129	230116	230046/30	●	●
S25S-MDUNR/L15	30	25	250	45	24	16	12°							●	●
S32T-MDUNR/L15	38	32	300	50	30	21	17°							●	●
S40T-MDUNR/L15	48	40	300	60	38	26	15°							●	●
S20R-DDUNR/L11	26	20	200	40	19	14.5	15°	DN..1104.. DN..1504.. DN..1506..			230138		230048	●	●
S25S-DDUNR/L15	30	25	250	45	24	16	12°							●	●
S32T-DDUNR/L15	38	32	300	50	30	21	17°							●	●
S40T-DDUNR/L15	48	40	300	60	38	26	15°							●	●
S32T-EDUNR/L15	40	32	300	50	30	22	10°	DN..1504.. DN..1506..	230023	230015	230142	230112	230048	○	○
S40T-EDUNR/L15	50	40	300	60	38	27	10°							230022	230049

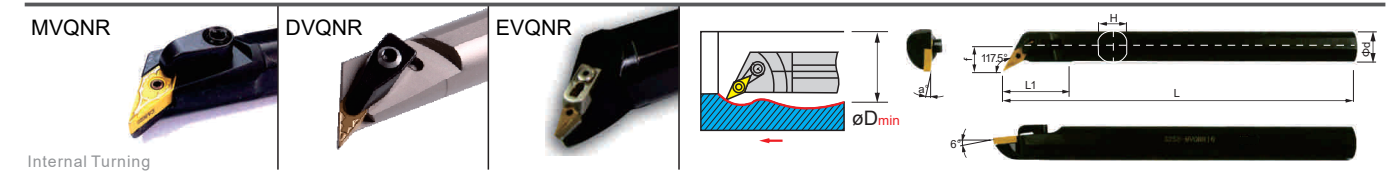

Ordering code	Dimensions							刀片 Insert	Shim	Pin	Clamp	Screw	Wrench	Stock	
	ϕD_{min}	ϕd	L	L1	H	f	α°							R	L
S20R-MVQNR/L16	28	20	200	45	19	16	15°	VN..1604..		230001	230133	230116	230046/30	●	●
S25S-MVQNR/L16	31	25	250	45	24	17	12°							●	●
S32T-MVQNR/L16	39	32	300	50	30	23	17°							●	●
S40T-MVQNR/L16	50	40	300	55	38	27	15°							●	●
S20R-DVQNR/L16	28	20	200	45	19	16	15°	VN..1604..			230138	230108	230048	○	○
S25S-DVQNR/L16	31	25	250	45	24	17	12°							○	○
S32T-DVQNR/L16	39	32	300	50	30	23	17°							○	○
S40T-DVQNR/L16	50	40	300	55	38	27	15°							○	○
S32T-EVQNR/L16	42	32	300	50	30	23	17°	VN..1604..	230029	230005	230146	230112	230047	○	○
S40T-EVQNR/L16	50	40	300	55	38	27	15°							230049	○

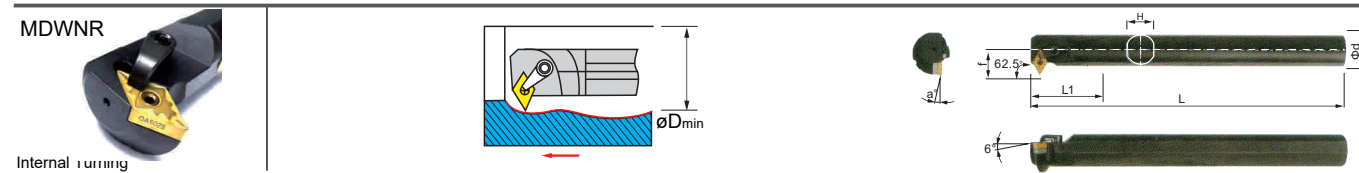

Ordering code	Dimensions							Insert	Shim	Pin	Clamp	Screw	Wrench	Stock	
	ϕD_{min}	ϕd	L	L1	H	f	α°							R	L
S20R-MDWNR/L11	28	20	200	36	19	16	15°	DN..1104.. DN..1504.. DN..1506..		230001	230129	230116	230046/48	●	●
S25S-MDWNR/L15	37	25	250	45	24	22.5	12°							●	●
S32T-MDWNR/L15	45	32	300	50	30	27	17°							●	●
S40T-MDWNR/L15	53	40	300	55	38	31	15°							●	●

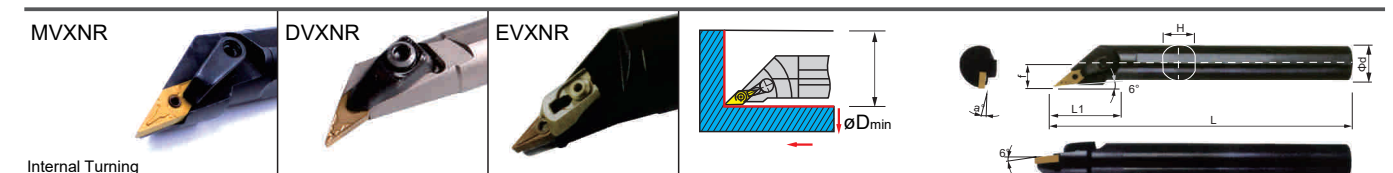

Ordering code	Dimensions							Insert	Shim	Pin	Clamp	Screw	Wrench	Stock	
	ϕD_{min}	ϕd	L	L1	H	f	α°							R	L
S20R-MVXNR/L16	27	20	200	40	19	14	15°	VN..1604..		230001	230135	230116	230046/30	●	●
S25S-MVXNR/L16	32	25	250	45	24	17	12°							●	●
S32T-MVXNR/L16	42	32	300	50	30	23	17°							●	●
S40T-MVXNR/L16	50	40	300	55	38	27	15°							●	●
S20R-DVXNR/L16	27	20	200	40	19	14	15°	VN..1604..			230139	230108	230048	○	○
S25S-DVXNR/L16	32	25	250	45	24	17	12°							○	○
S32T-DVXNR/L16	42	32	300	50	30	23	17°							○	○
S40T-DVXNR/L16	50	40	300	55	38	27	15°							○	○
S32T-EVXNR/L16	42	32	300	50	30	23	17°	VN..1604..	230029	230005	230146	230112	230047	○	○
S40T-EVXNR/L16	50	40	300	55	38	27	15°							230049	○

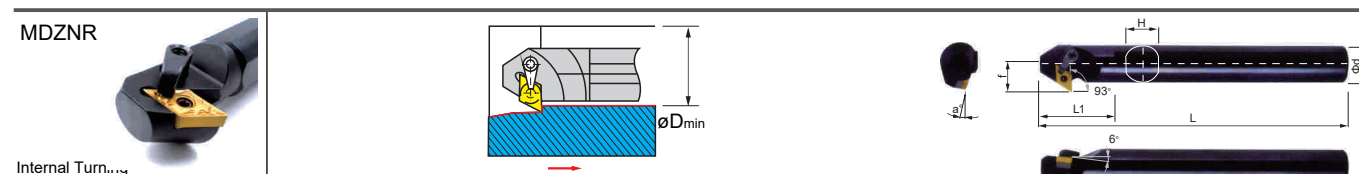

Ordering code	Dimensions							Insert	Shim	Pin	Clamp	Screw	Wrench	Stock	
	ϕD_{min}	ϕd	L	L1	H	f	α°							R	L
S25S-MDZNR/L15	35	25	250	46	24	20.5	15°	DN..1504.. DN..1506..	230023	230010	230133	230116	230048	●	●
S32T-MDZNR/L15	40	32	300	50	30	23	17°							●	●
S40T-MDZNR/L15	50	40	300	55	38	27	15°							230022	●

M | D | E | P Type Internal Turning Tool

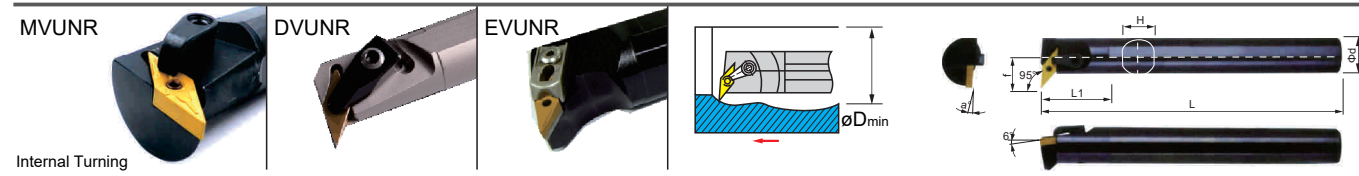

Ordering code	Dimensions							Insert	Shim	Pin	Clamp	Screw	Wrench	Stock	
	ϕD_{min}	ϕd	L	L1	H	f	α°							R	L
S20R-MVUNR/L16	32	20	200	45	19	20	15°	VN..1604..		230001	230133	230116	230046 230048	●	●
S25S-MVUNR/L16	34	25	250	45	24	20	12°							●	●
S32T-MVUNR/L16	40	32	300	50	30	22	17°							●	●
S40T-MVUNR/L16	48	40	300	55	38	26	15°							●	●

Ordering code	Dimensions							Insert	Shim	Shim Screw	压板 Clamp	Screw	Wrench	Stock	
	ϕD_{min}	ϕd	L	L1	H	f	α°							R	L
S20R-DVUNR/L16	32	20	200	45	19	20	15°	VN..1604..		230013	230138	230108	230048	○	○
S25S-DVUNR/L16	34	25	250	45	24	20	12°							○	○
S32T-DVUNR/L16	40	32	300	50	30	22	17°							○	○
S40T-DVUNR/L16	48	40	300	55	38	26	15°							○	○

Ordering code	Dimensions							Insert	Shim	Pin	Clamp	Screw	Wrench	Stock	
	ϕD_{min}	ϕd	L	L1	H	f	α°							R	L
S32T-EVUNR/L16	42	32	300	50	30	23	17°	VN..1604..	230029	230005	230146	230112	230047 230049	○	○
S40T-EVUNR/L16	50	40	300	55	38	27	15°							○	○

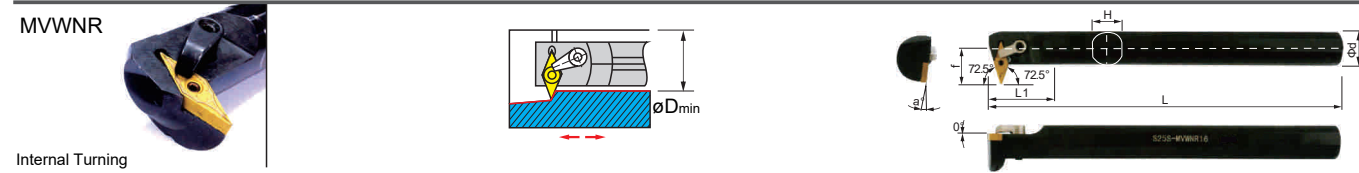

Ordering code	Dimensions							Insert	Shim	Pin	Clamp	Screw	Wrench	Stock	
	ϕD_{min}	ϕd	L	L1	H	f	α°							R	L
S25S-MVWNR/L16	40	25	250	45	24	26	12°	VN..1504..		230001	230133	230115	230046 230048	●	●
S32T-MVWNR/L16	48	32	300	50	30	30	17°							●	●

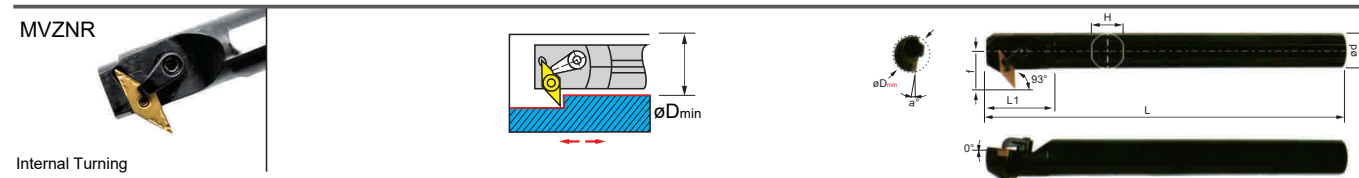

Ordering code	Dimensions							Insert	Shim	Pin	Clamp	Screw	Wrench	Stock	
	ϕD_{min}	ϕd	L	L1	H	f	α°							R	L
S25S-MVZNR/L16	40	25	250	45	23	26	12°	VN..1504..		230001	230133	230115	230046 230048	●	●
S32T-MVZNR/L16	48	32	300	50	30	30	17°							●	●

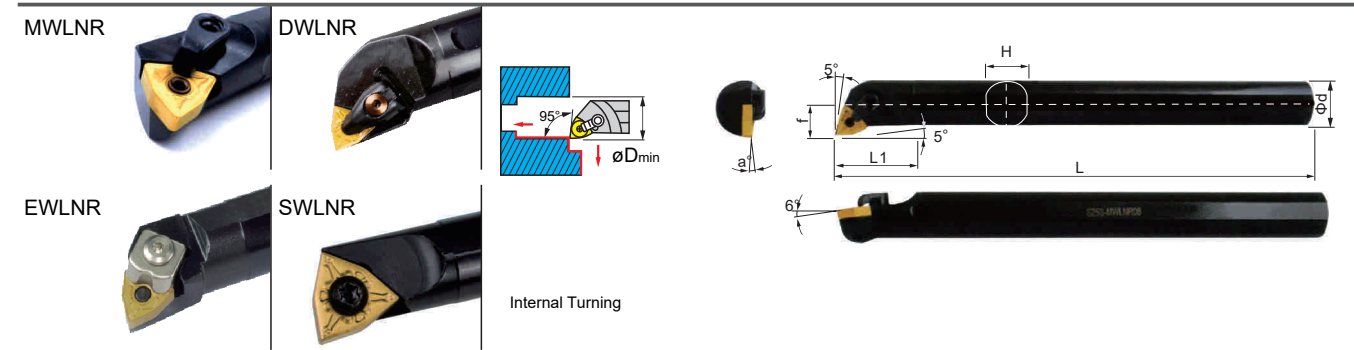

Ordering code	Dimensions							Insert	Shim	Pin	Clamp	Screw	Wrench	Stock	
	ϕD_{min}	ϕd	L	L1	H	f	α°							R	L
S16Q-MWLNR/L06	20	16	180	35	15	11	18°	WN..0604..		230001	230127	230114	230046 230048	●	●
S18Q-MWLNR/L06	22	18	180	35	17	12	15°							●	●
S20R-MWLNR/L06	24	20	200	40	19	13	15°							●	●
S25S-MWLNR/L06	32	25	250	45	23	17	12°							●	●
S32T-MWLNR/L06	40	32	300	50	30	22	17°							●	●
S40T-MWLNR/L06	50	40	300	60	37	27	15°							●	●
S16Q-MWLNR/L08	20	16	180	35	15	11	15°	WN..0804..		230006	230129	230115	230046 230048	●	●
S18Q-MWLNR/L08	22	18	180	35	17	12	15°							●	●
S20R-MWLNR/L08	25	20	200	40	19	13	15°							●	●
S25S-MWLNR/L08	30	25	250	46	23	16.5	12°							●	●
S32T-MWLNR/L08	38	32	300	50	30	20	17°							●	●
S40T-MWLNR/L08	46	40	300	60	37	24	15°							●	●
S50U-MWLNR/L08	60	50	350	70	48	31	12°	●	●						
S60V-MWLNR/L08	70	60	400	70	58	36	10°	●	●						

Ordering code	Dimensions							Insert	Shim	Pin	Clamp	Screw	Wrench	Stock	
	ϕD_{min}	ϕd	L	L1	H	f	α°							R	L
S25S-WWLNR/L16	32	25	250	40	23	17	12°	WN..0804..	230031	230009	230149	230104	230048 230049	●	○
S32T-WWLNR/L16	40	32	300	50	30	22	17°							●	○
S40U-WWLNR/L16	45	40	350	60	38	27	15°							●	○
S50W-WWLNR/L16	55	50	450	70	48	31	12°							●	○

Ordering code	Dimensions							Insert	Shim	Shim Screw	Clamp	Screw	Wrench	Stock	
	ϕD_{min}	ϕd	L	L1	H	f	α°							R	L
S20R-DWLNR/L06	24	20	200	40	19	13	15°	WN..0604..		230013	230138	230108	230048	○	○
S25S-DWLNR/L06	32	25	250	45	24	17	12°							○	○
S32T-DWLNR/L06	40	32	300	50	30	22	17°							○	○
S40T-DWLNR/L06	50	40	300	60	38	27	15°							○	○
S20R-DWLNR/L08	25	20	200	40	19	13	15°	WN..0804..		230014	230136	230108	230048	○	○
S25S-DWLNR/L08	30	25	250	45	24	16.5	12°							○	○
S32T-DWLNR/L08	38	32	300	50	30	20	17°							○	○
S40T-DWLNR/L08	46	40	300	60	38	24	15°							○	○

Ordering code	Dimensions							Insert	Shim	Pin	Clamp	Screw	Wrench	Stock	
	ϕD_{min}	ϕd	L	L1	H	f	α°							R	L
S25S-EWLNR/L08	32	25	250	45	24	17	15°	WN..0804..		230015	230147	230112	230048 230049	○	○
S32T-EWLNR/L08	40	32	300	50	30	22	15°							○	○
S40T-EWLNR/L08	50	40	300	60	38	27	12°							○	○
S50U-EWLNR/L08	60	50	350	70	48	35	12°							○	○

Ordering code	Dimensions							Insert	Screw	Wrench	Stock	
	ϕD_{min}	ϕd	f	L	L1	H	α°				R	L
S16Q-SWLNR/L08	21	16	11.5	180	26	14.8	15°	WN..0804..	230099	230058	●	●
S18Q-SWLNR/L08	23	18	12.5	180	28	16.8	15°				●	●
S20R-SWLNR/L08	25	20	13.5	200	28	18.4	15°				●	●

S Type Internal Turning Tool

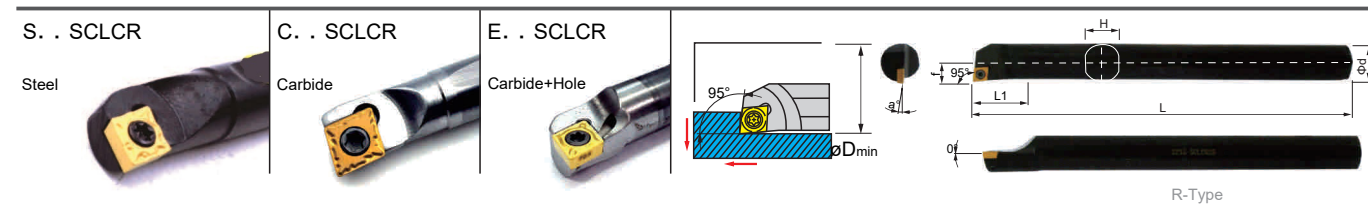

Internal Turning

Ordering code	Dimensions							Insert	Screw	Wrench	Stock	
	øD _{min}	ød	f	L	L1	H	α°				R	L
S07K-SCLCR/L06	9	7	4.9	125	14	6	15°	CC..0602..	230073	230054	•	•
S08K-SCLCR/L06	10	8	5	125	14	7	15°				•	•
S10K-SCLCR/L06	12	10	6	125	14	9	13°				•	•
S12M-SCLCR/L06	16	12	9	150	25	11	10°				•	•
S16Q-SCLCR/L06	20	16	11	180	32	15	8°				•	•
S12M-SCLCR/L09	16	12	9	150	25	11	10°	CC..09T3..	230090	230057	•	•
S14N-SCLCR/L09	18	14	10	160	26	13	12°				•	•
S16Q-SCLCR/L09	20	16	11	180	28	15	12°				•	•
S18Q-SCLCR/L09	22	18	12	180	28	17	8°				•	•
S20R-SCLCR/L09	25	20	13	200	32.5	18	8°				•	•
S25S-SCLCR/L09	32	25	17	250	45	23	6°	CC..1204..	230101	230058	•	•
S25S-SCLCR/L12	32	25	17	250	45	23	6°				•	•
S32T-SCLCR/L12	40	32	22	300	20	30	10°				•	•
S40T-SCLCR/L12	50	40	27	300	60	37	8°				•	•
S10K-SCLPR/L08	12	10	6	125	14	9	13°				CP..0802..	230076
S12M-SCLPR/L08	14	12	7	150	25	11	10°	•	•			
S12M-SCLPR/L09	14	12	7	150	25	11	10°	CP..0903..	230090	230057	•	•
S16Q-SCLPR/L09	18	16	9	180	28	15	10°				•	•
S20R-SCLPR/L09	22	20	11	200	32	19	8°				•	•

Carbide Steel Shock-Proof Toolholder(Shock-Proof Effect > 8 Times Toolholder Diameter)

Ordering code	Dimensions							Insert	Screw	Wrench	Stock	
	øD _{min}	ød	f	L	L1	H	α°				R	L
C04G-SCLCR/L03-05	5	4	2.8	90	10	3.6	15°	CC..0301..	230065	230052	•	•
C05H-SCLCR/L03-06	6	5	3	100	10	4.5	15°				•	•
C05H-SCLCR/L04-06	6	5	3	100	10	4.5	15°	CC..0401..	230069	230053	•	•
C06J-SCLCR/L04-07	7	6	3.5	110	12	5.4	15°				•	•
C07J-SCLCR/L04-08	8	7	4	110	15	6	15°				•	•
C08K-SCLCR/L06-10	10	8	5	125	15	7	15°	CC..0602..	230074	230054	•	•
C10M-SCLCR/L06-12	12	10	6	150	15	9	13°				•	•
C12M-SCLCR/L06-14	14	12	7	150	20	11	10°				•	•
C12Q-SCLCR/L06-14	14	12	7	180	20	11	10°				•	•
C16R-SCLCR/L06-18	18	16	9	200	25	15	8°				•	•
C12M-SCLCR/L09-14	14	12	7	150	20	11	12°	CC..09T3..	230090	230057	•	•
C12Q-SCLCR/L09-14	14	12	7	180	20	11	12°				•	•
C14M-SCLCR/L09-16	16	14	8	150	20	13	12°				•	•
C16M-SCLCR/L09-18	18	16	9	150	25	15	12°				•	•
C16R-SCLCR/L09-18	18	16	9	200	25	15	12°				•	•
C20R-SCLCR/L09-22	22	20	11	200	30	19	8°	CP..0802..	230076	230055	•	•
C20S-SCLCR/L09-22	22	20	11	250	30	19	8°				•	•
C25R-SCLCR/L09-32	29	25	14.5	200	35	24	6°				•	•
C25S-SCLCR/L09-32	29	25	14.5	250	35	24	6°	CP..0903..	230090	230057	•	•
C10M-SCLPR/L08-12	12	10	6	150	15	9	13°				•	•
C12Q-SCLPR/L08-14	14	12	7	180	20	11	10°				•	•
C12Q-SCLPR/L09-14	14	12	7	180	20	11	12°	CP..0903..	230090	230057	•	•
C16R-SCLPR/L09-18	18	16	9	200	25	15	12°				•	•
C04G-SJLCL/L03-055	5.5	4	2.95	90	10	3.6	15°				JC..0301..	230065

Carbide Steel Shock-Proof Hollow Toolholder(Shock-Proof Effect > 8 Times Toolholder Diameter)

Ordering code	Dimensions							Insert	Screw	Wrench	Stock	
	øD _{min}	ød	f	L	L1	H	α°				R	L
E05H-SCLCR/L03-06	6	5	3	100	10	4.5	15°	CC..0301..	230065	230052	•	•
E06J-SCLCR/L04-07	7	6	3.5	110	12	5.4	15°				•	•
E08K-SCLCR/L06-10	10	8	5	125	15	7	15°	CC..0602..	230074	230054	•	•
E10M-SCLCR/L06-12	12	10	6	150	15	9	13°				•	•
E12M-SCLCR/L06-14	14	12	7	150	20	11	10°				•	•
E12Q-SCLCR/L06-14	14	12	7	180	20	11	10°				•	•
E16R-SCLCR/L06-18	18	16	9	200	25	15	8°				•	•
E12M-SCLCR/L09-14	14	12	7	150	20	11	12°	CC..09T3..	230090	230057	•	•
E12Q-SCLCR/L09-14	14	12	7	180	20	11	12°				•	•
E16R-SCLCR/L09-18	18	16	9	200	25	15	12°				•	•
E20R-SCLCR/L09-22	22	20	11	200	30	19	8°				•	•
E20S-SCLCR/L09-22	22	20	11	250	30	19	8°				•	•

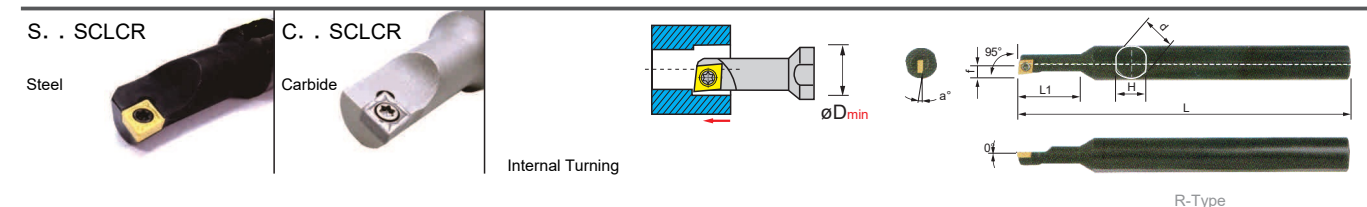

Internal Turning

R-Type

Ordering code	Dimensions							Insert	Screw	Wrench	Stock	
	øD _{min}	ød	f	L	L1	H	α°				R	L
S07M-SCLCR/L06-A16	9	16	4.5	150	20	15	15°	CC..0602..	230073	230054	•	•
S08M-SCLCR/L06-A16	10	16	5	150	20	15	13°				•	•
S10M-SCLCR/L06-A16	12	16	6	150	20	15	12°				•	•
S12M-SCLCR/L06-A16	14	16	7	150	25	15	10°				•	•
S12M-SCLCR/L09-A16	16	16	8	150	25	15	10°				•	•
S14Q-SCLCR/L09-A16	16	16	8	180	35	15	10°	CC..09T3..	230090	230057	•	•
S14Q-SCLCR09/L-A16-60L	16	16	8	180	60	15	10°				•	•

Carbide Steel Shock-Proof Toolholder(Shock-Proof Effect > 8 Times Toolholder Diameter)

C0604H-SCLCR/L03-05-10	5	6	2.5	100	10	5.5	15°	CC..0301..	230065	230052	•	•
C0605H-SCLCR/L03-06-10	6	6	3	100	10	5.5	15°				•	•
C0807K-SCLCR/L04-08-15	8	8	4	125	15	7	15°	CC..0301..	230069	230053	•	•

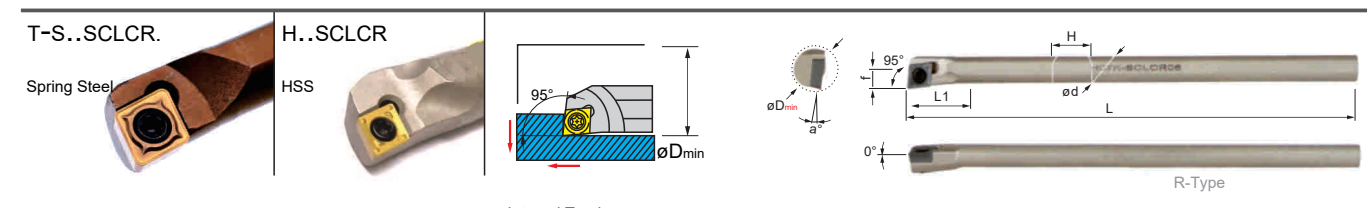

Internal Turning

R-Type

Spring Steel Shock-Proof Toolholder(Shock-Proof Effect > 4 Times Toolholder Diameter)

Ordering code	Dimensions							Insert	Screw	Wrench	Stock	
	øD _{min}	ød	f	L	L1	H	α°				R	L
T-S07K-SCLCR/L06	9	7	4.9	125	14	6	15°	CC..0602..	230073	230054	•	•
T-S08K-SCLCR/L06	10	8	5	125	14	7	15°				•	•
T-S10K-SCLCR/L06	12	10	6	125	14	9	13°				•	•
T-S12M-SCLCR/L06	16	12	9	150	25	11	10°				•	•
T-S16Q-SCLCR/L06	20	16	11	180	32	15	8°				•	•
T-S12M-SCLCR/L09	16	12	9	150	25	11	10°	CC..09T3..	230090	230057	•	•
T-S14N-SCLCR/L09	18	14	10	160	26	13	12°				•	•
T-S16Q-SCLCR/L09	20	16	11	180	28	15	12°				•	•
T-S18Q-SCLCR/L09	22	18	12	180	28	17	8°				•	•
T-S20R-SCLCR/L09	25	20	13	200	32.5	18	8°				•	•
T-S25S-SCLCR/L09	32	25	17	250	45	23	6°	•	•			

High-Speed Steel Shock-Proof Toolholder(Shock-Proof Effect > 5 Times Toolholder Diameter)

H04F-SCLCR/L03	4.8	4	2.5	80	15	3.6	15°	CC..0301..	230065	230052	•	•
H05G-SCLCR/L03	5.5	5	2.8	90	15	4.5	15°				•	•
H05H-SCLCR/L04	5.8	5	2.8	100	22	4.5	15°	CC..0401..	230069	230053	•	•
H06J-SCLCR/L04	7	6	3.5	110	25	5	15°				•	•
H07K-SCLCR/L06	9	7	4.9	125	35	6	15°				•	•
H08K-SCLCR/L06	10	8	5	125	40	7	15°	CC..0602..	230074	230054	•	•
H10K-SCLCR/L06	12	10	6	125	50	9	13°				•	•
H12M-SCLCR/L06	14	12	7	150	60	11	10°				•	•
H12M-SCLCR/L09	16	12	9	150	60	11	12°				•	•
H14Q-SCLCR/L09	16	14	8.5	180	70	13	12°				•	•
H16R-SCLCR/L09	18	16	9.5	200	80	15	12°	CC..09T3..	230090	230057	•	•
H18R-SCLCR/L09	20	18	10.5	200	90	17	8°				•	•
H20X-SCLCR/L09	22	20	11.5	230	100	19	8°				•	•
H25S-SCLCR/L09	28	25	15	250	100	23	6°				•	•

S Type Internal Turning Tool

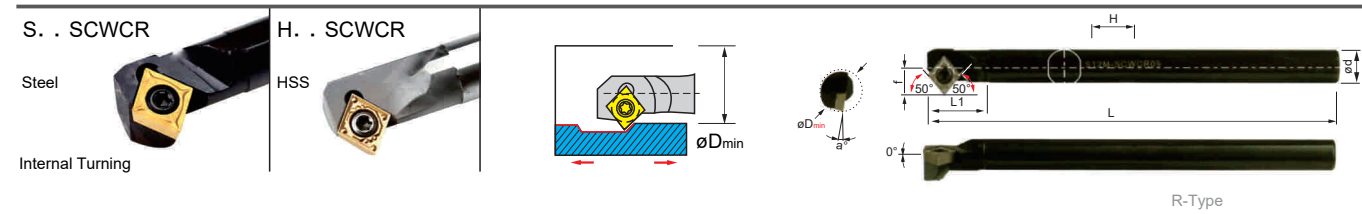

Ordering code	Dimensions							Insert	Screw	Wrench	Stock	
	ϕD_{min}	ϕd	f	L	L1	H	α°				R	L
S08K-SCWCR/L06	12	8	7	125	14	7	13°	CC..0602..	230074	230054	•	•
S10K-SCWCR/L06	14	10	8	125	14	9	13°				•	•
S12M-SCWCR/L06	16	12	9	150	16	11	10°				•	•
S12M-SCWCR/L09	17	12	9.5	150	18	11	10°	CC..09T3..	230090	230057	•	•
S16Q-SCWCR/L09	21	16	11.5	180	20	15	10°				•	•
S20R-SCWCR/L09	25	20	13.5	200	22	19	8°				•	•
High-Speed Steel Shock-Proof Toolholder (Shock-Proof Effect > 5 Times Toolholder Diameter)												
H08K-SCWCR/L06	12	8	7	125	14	7	13°	CC..0602..	230074	230054	•	•
H10K-SCWCR/L06	14	10	8	125	14	9	13°				•	•
H12M-SCWCR/L06	16	12	9	150	16	11	10°				•	•
H12M-SCWCR/L09	17	12	9.5	150	18	11	10°	CC..09T3..	230090	230057	•	•
H16Q-SCWCR/L09	21	16	11.5	180	20	15	10°				•	•
H20R-SCWCR/L09	25	20	13.5	200	22	19	8°				•	•

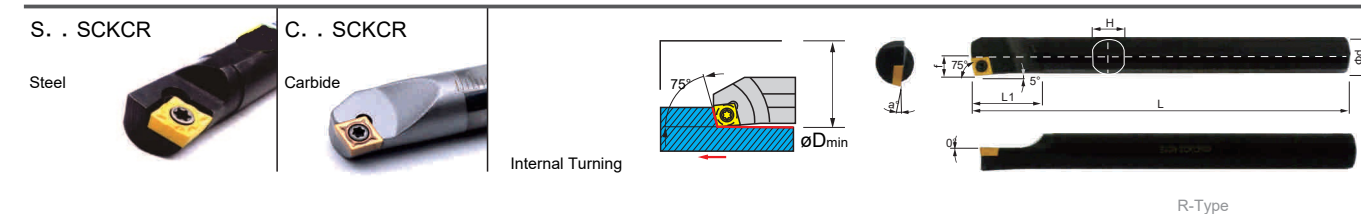

Ordering code	Dimensions							Insert	Screw	Wrench	Stock	
	ϕD_{min}	ϕd	f	L	L1	H	α°				R	L
S08K-SCKCR/L06	10.5	8	5.5	125	20	7	13°	CC..0602..	230074	230054	•	•
S10K-SCKCR/L06	13.5	10	6	125	22	9	12°				•	•
S12M-SCKCR/L06	16	12	7	150	23	11	10°				•	•
S12M-SCKCR/L09	14	12	8	150	30	11	12°	CC..09T3..	230090	230057	•	•
S14N-SCKCR/L09	15	14	8	160	30	13	10°				•	•
S16Q-SCKCR/L09	18	16	9.5	180	30	15	10°				•	•
S20R-SCKCR/L09	23	20	11.5	200	35	19	8°	CC..1204..	230090	230057	•	•
S25S-SCKCR/L09	31	25	14	250	40	24	6°				•	•
S16Q-SCKCR/L12	19	16	9.5	180	30	15	10°				•	•
S20R-SCKCR/L12	23	20	12	200	40	19	10°	•	•			
Carbide Steel Shock-Proof Toolholder (Shock-Proof Effect > 8 Times Toolholder Diameter)												
C08K-SCKCR/L06	10	8	5.5	125	15	7	13°	CC..0602..	230074	230054	•	•
C10K-SCKCR/L06	13	10	6	125	15	9	12°				•	•
C12M-SCKCR/L06	16	12	7	150	20	11	10°				•	•
C12M-SCKCR/L09	16	12	7	150	20	11	12°	CC..09T3..	230090	230057	•	•
C16Q-SCKCR/L09	20	16	9	180	25	13	10°				•	•
C20R-SCKCR/L09	24	20	11.5	200	30	15	10°				•	•
C20S-SCKCR/L09	24	20	11.5	250	30	19	8°	•	•			

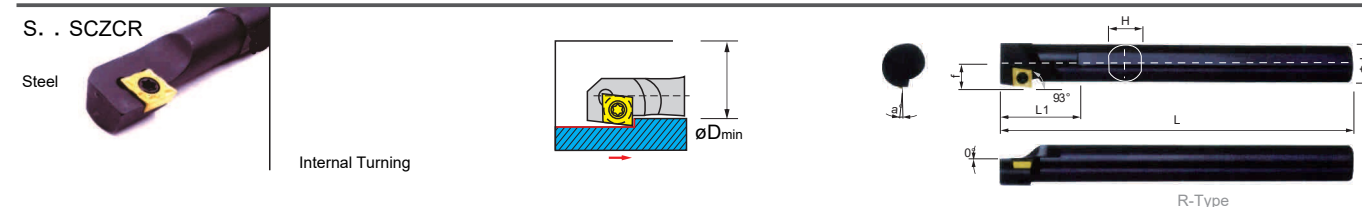

Ordering code	Dimensions							Insert	Screw	Wrench	Stock	
	ϕD_{min}	ϕd	f	L	L1	H	α°				R	L
S08K-SCZCR/L06	12	8	6.5	125	25	7	13°	CC..0602..	230074	230054	•	•
S10K-SCZCR/L06	14	10	7.5	125	27	9	12°				•	•
S12M-SCZCR/L06	16	12	8.5	150	30	11	10°				•	•
S16Q-SCZCR/L06	20	16	10.5	180	35	15	18°	CC..09T3..	230090	230057	•	•
S12M-SCZCR/L09	17	12	10	150	30	11	12°				•	•
S16Q-SCZCR/L09	21	16	11.5	180	35	15	10°				•	•
S20R-SCZCR/L09	25	20	13.5	200	40	19	8°	CC..09T3..	230090	230057	•	•
S25S-SCZCR/L09	32	25	16	250	42	24	6°				•	•
Carbide Steel Shock-Proof Toolholder (Shock-Proof Effect > 8 Times Toolholder Diameter)												
C04X-SJZCR/L03-065	6.5	4	4	93	4.8	3.6	15°	JC..0301..	230065	230052	•	•

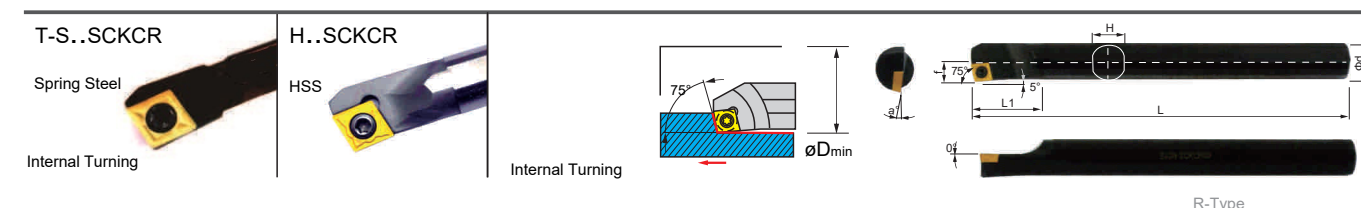

Ordering code	Dimensions							Insert	Screw	Wrench	Stock	
	ϕD_{min}	ϕd	f	L	L1	H	α°				R	L
T-S08K-SCKCR/L06	10.5	8	5.5	125	20	7	13°	CC..0602..	230074	230054	•	•
T-S10K-SCKCR/L06	13.5	10	6	125	22	9	12°				•	•
T-S12M-SCKCR/L06	16	12	7	150	23	11	10°				•	•
T-S12M-SCKCR/L09	14	12	8	150	30	11	12°	CC..09T3..	230090	230057	•	•
T-S14N-SCKCR/L09	15	14	8	160	30	13	10°				•	•
T-S16Q-SCKCR/L09	18	16	9.5	180	30	15	10°				•	•
T-S20R-SCKCR/L09	23	20	11.5	200	35	19	8°	CC..09T3..	230090	230057	•	•
T-S25S-SCKCR/L09	31	25	14	250	40	24	6°				•	•
H08K-SCKCR/L06	10.5	8	5.5	125	20	7	13°				CC..0602..	230074
H10K-SCKCR/L06	13.5	10	6	125	22	9	12°	•	•			
H12M-SCKCR/L06	16	12	7	150	23	11	10°	•	•			
H12M-SCKCR/L09	14	12	8	150	30	11	12°	CC..09T3..	230090	230057	•	•
H14N-SCKCR/L09	15	14	8	160	30	13	10°				•	•
H16Q-SCKCR/L09	18	16	9.5	180	30	15	10°				•	•
H20R-SCKCR/L09	23	20	11.5	200	35	19	8°	CC..09T3..	230090	230057	•	•
H25S-SCKCR/L09	31	25	14	250	40	24	6°				•	•

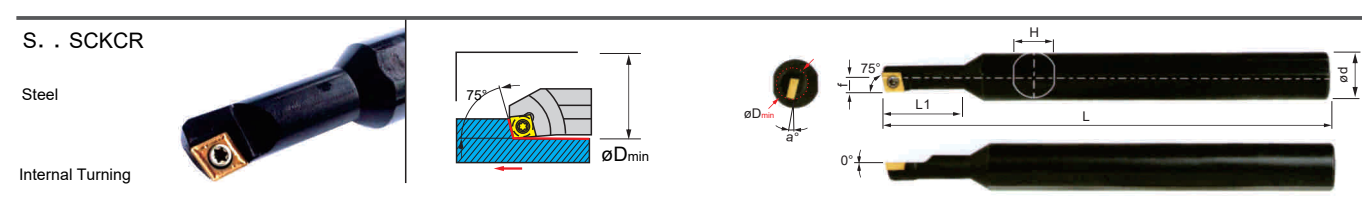

Ordering code	Dimensions							Insert	Screw	Wrench	Stock	
	ϕD_{min}	ϕd	f	L	L1	H	α°				R	L
S07M-SCKCR/L06-A16	9	16	4.9	150	25	15	15°	CC..0602..	230074	230054	•	•
S08M-SCKCR/L06-A16	10	16	5.5	150	28	15	13°				•	•
S10M-SCKCR/L06-A16	12	16	6	150	30	15	12°				•	•
S12M-SCKCR/L06-A16	14	16	7	150	35	15	10°				•	•

S Type Internal Turning Tool

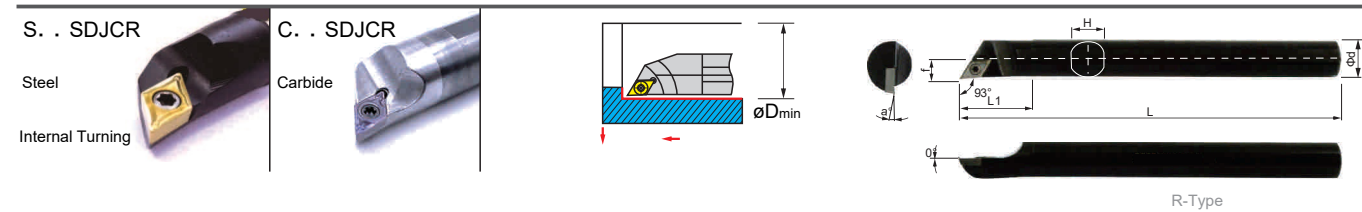

Ordering code	Dimensions							Insert	Screw	Wrench	Stock	
	ϕD_{min}	ϕd	f	L	L1	H	α°				R	L
S08K-SDJCR/L07	10	8	5.5	125	20	5.5	12°	DC..0702..	230074	230054	•	•
S10K-SDJCR/L07	13	10	7	125	25	7	10°				•	•
S12M-SDJCR/L07	16	12	9	150	30	8.5	8°				•	•
S16Q-SDJCR/L07	20	16	11	180	30	11	6°	•	•	•	•	
S16Q-SDJCR/L11	20	16	9.5	180	35	11	10°	DC..11T3..	230092	230057	•	•
S20R-SDJCR/L11	25	20	13	200	40	13	6°				•	•
S25S-SDJCR/L11	32	25	17	250	40	17	4°				•	•

Carbide Steel Shock-Proof Toolholder(Shock-Proof Effect > 8 Times Toolholder Diameter)

Ordering code	Dimensions							Insert	Screw	Wrench	Stock	
	ϕD_{min}	ϕd	f	L	L1	H	α°				R	L
C08K-SDJCR/L07	10	8	5.5	125	15	7	12°	DC..0702..	230074	230054	•	•
C10M-SDJCR/L07	13	10	7	150	15	9	10°				•	•
C12M-SDJCR/L07	16	12	9	150	20	11	8°				•	•
C16R-SDJCR/L07	20	16	11	200	25	15	6°	•	•	•	•	
C20R-SDJCR/L11	25	20	13	200	30	19	6°	DC..11T3..	230092	230057	•	•
C20S-SDJCR/L11	25	20	13	250	30	19	6°				•	•
C25R-SDJCR/L11	32	25	17	200	35	24	4°				•	•
C25S-SDJCR/L11	32	25	17	250	35	24	4°	•	•			

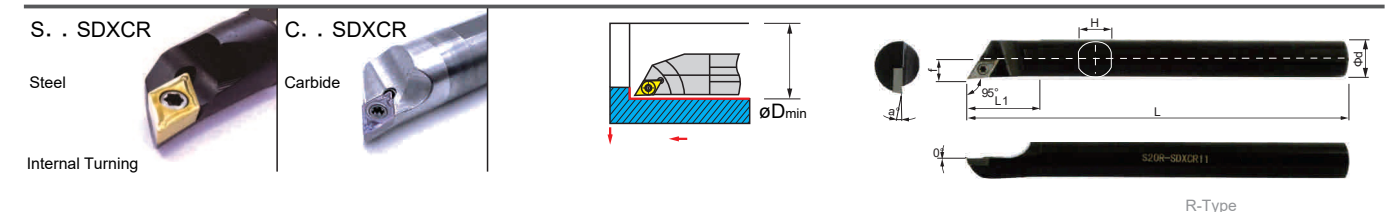

Ordering code	Dimensions							Insert	Screw	Wrench	Stock	
	ϕD_{min}	ϕd	f	L	L1	H	α°				R	L
S08K-SDXCR/L07	10	8	5.5	125	20	5.5	12°	DC..0702..	230074	230054	•	•
S10K-SDXCR/L07	13	10	7	125	25	7	10°				•	•
S12M-SDXCR/L07	16	12	9	150	30	8.5	8°				•	•
S16Q-SDXCR/L07	20	16	11	180	30	11	6°	•	•	•	•	
S16Q-SDXCR/L11	20	16	9.5	180	35	11	10°	DC..11T3..	230092	230057	•	•
S20R-SDXCR/L11	25	20	13	200	40	13	6°				•	•
S25S-SDXCR/L11	32	25	17	250	40	17	4°				•	•

Carbide Steel Shock-Proof Toolholder(Shock-Proof Effect > 8 Times Toolholder Diameter)

Ordering code	Dimensions							Insert	Screw	Wrench	Stock	
	ϕD_{min}	ϕd	f	L	L1	H	α°				R	L
C08K-SDXCR/L07	10	8	5.5	125	15	7	12°	DC..0702..	230074	230054	•	•
C10M-SDXCR/L07	13	10	7	150	15	9	10°				•	•
C12M-SDXCR/L07	16	12	9	150	20	11	8°				•	•
C16R-SDXCR/L07	20	16	11	200	25	15	6°	•	•	•	•	
C20R-SDXCR/L11	25	20	13	200	30	19	6°	DC..11T3..	230092	230057	•	•
C20S-SDXCR/L11	25	20	13	250	30	19	6°				•	•
C25R-SDXCR/L11	32	25	17	200	35	24	4°				•	•
C25S-SDXCR/L11	32	25	17	250	35	24	4°	•	•			

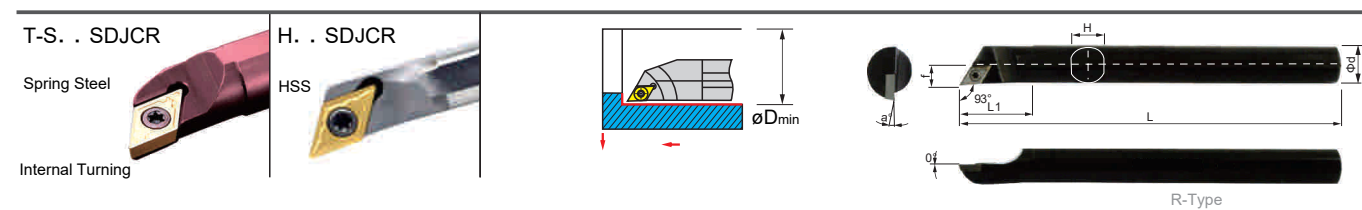

Ordering code	Dimensions							Insert	Screw	Wrench	Stock	
	ϕD_{min}	ϕd	f	L	L1	H	α°				R	L
T-S08K-SDJCR/L07	10	8	5.5	125	20	5.5	12°	DC..0702..	230074	230054	•	•
T-S10K-SDJCR/L07	13	10	7	125	25	7	10°				•	•
T-S12M-SDJCR/L07	16	12	9	150	30	8.5	8°				•	•
T-S16Q-SDJCR/L07	20	16	11	180	30	11	6°	•	•	•	•	
T-S16Q-SDJCR/L11	20	16	9.5	180	35	11	10°	DC..11T3..	230092	230057	•	•
T-S20R-SDJCR/L11	25	20	13	200	40	13	6°				•	•
T-S25S-SDJCR/L11	32	25	17	250	40	17	4°				•	•

Spring Steel Shock-Proof Toolholder (Shock-Proof Effect > 4 Times Toolholder Diameter)

Ordering code	Dimensions							Insert	Screw	Wrench	Stock	
	ϕD_{min}	ϕd	f	L	L1	H	α°				R	L
H08K-SDJCR/L07	10	8	5.5	125	20	5.5	12°	DC..0702..	230074	230054	•	•
H10K-SDJCR/L07	13	10	7	125	25	7	10°				•	•
H12M-SDJCR/L07	16	12	9	150	30	8.5	8°				•	•
H16Q-SDJCR/L07	20	16	11	180	30	11	6°	•	•	•	•	
H16Q-SDJCR/L11	20	16	9.5	180	35	11	10°	DC..11T3..	230092	230057	•	•
H20R-SDJCR/L11	25	20	13	200	40	13	6°				•	•
H25S-SDJCR/L11	32	25	17	250	40	17	4°				•	•

High-Speed Steel Shock-Proof Toolholder (Shock-Proof Effect > 5 Times Toolholder Diameter)

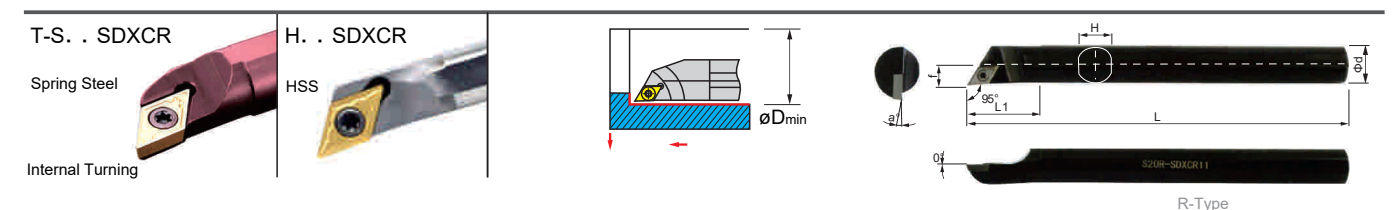

Ordering code	Dimensions							Insert	Screw	Wrench	Stock	
	ϕD_{min}	ϕd	f	L	L1	H	α°				R	L
T-S08K-SDXCR/L07	10	8	5.5	125	20	5.5	12°	DC..0702..	230074	230054	•	•
T-S10K-SDXCR/L07	13	10	7	125	25	7	10°				•	•
T-S12M-SDXCR/L07	16	12	9	150	30	8.5	8°				•	•
T-S16Q-SDXCR/L07	20	16	11	180	30	11	6°	•	•	•	•	
T-S16Q-SDXCR/L11	20	16	9.5	180	35	11	10°	DC..11T3..	230092	230057	•	•
T-S20R-SDXCR/L11	25	20	13	200	40	13	6°				•	•
T-S25S-SDXCR/L11	32	25	17	250	40	17	4°				•	•

Spring Steel Shock-Proof Toolholder (Shock-Proof Effect > 4 Times Toolholder Diameter)

High-Speed Steel Shock-Proof Toolholder (Shock-Proof Effect > 5 Times Toolholder Diameter)

Ordering code	Dimensions							Insert	Screw	Wrench	Stock	
	ϕD_{min}	ϕd	f	L	L1	H	α°				R	L
H08K-SDXCR/L07	10	8	5.5	125	20	5.5	12°	DC..0702..	230074	230054	•	•
H10K-SDXCR/L07	13	10	7	125	25	7	10°				•	•
H12M-SDXCR/L07	16	12	9	150	30	8.5	8°				•	•
H16Q-SDXCR/L07	20	16	11	180	30	11	6°	•	•	•	•	
H16Q-SDXCR/L11	20	16	9.5	180	35	11	10°	DC..11T3..	230092	230057	•	•
H20R-SDXCR/L11	25	20	13	200	40	13	6°				•	•
H25S-SDXCR/L11	32	25	17	250	40	17	4°				•	•

High-Speed Steel Shock-Proof Toolholder (Shock-Proof Effect > 5 Times Toolholder Diameter)

S Type Internal Turning Tool

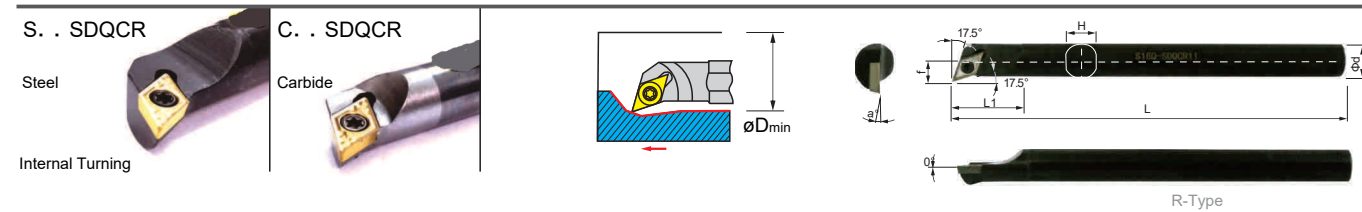

Ordering code	Dimensions							刀片 Insert	Screw	Wrench	Stock	
	ϕD_{min}	ϕd	f	L	L1	H	α°				R	L
S08K-SDQCR/L07	12	8	7	125	23	7	13°	DC..0702..	230074	230054	●	●
S10K-SDQCR/L07	13	10	7	125	23	9	10°				●	●
S12M-SDQCR/L07	16	12	9	150	30	11	8°				●	●
S14N-SDQCR/L07	17	14	9	160	30	13	8°				●	●
S16Q-SDQCR/L07	20	16	10.5	180	30	15	6°				●	●
S16Q-SDQCR/L11	20	16	10.5	180	30	15	6°	DC..11T3..	230090	230057	●	●
S20R-SDQCR/L11	23	20	13	200	39	19	6°				●	●
S25S-SDQCR/L11	30	25	16	250	40	24	4°				●	●
S32T-SDQCR/L11	38	32	20	300	43	30	4°				●	●

Carbide Steel Shock-Proof Toolholder(Shock-Proof Effect > 8 Times Toolholder Diameter)

C10M-SDQCR/L07	13	10	7	150	15	9	10°	DC..0702..	230074	230054	●	●
C12M-SDQCR/L07	16	12	9	150	20	11	8°				●	●
C12Q-SDQCR/L07	16	12	9	180	20	11	8°				●	●
C14M-SDQCR/L07	18	14	10	150	25	13	8°				●	●
C16M-SDQCR/L07	20	16	11	150	25	15	6°				●	●
C16R-SDQCR/L07	20	16	11	200	25	15	6°	DC..11T3..	230090	230057	●	●
C16M-SDQCR/L11	20	16	11	150	25	15	6°				●	●
C16R-SDQCR/L11	20	16	11	200	25	15	6°				●	●
C20R-SDQCR/L11	23	20	13	200	30	19	6°				●	●
C20S-SDQCR/L11	23	20	13	250	30	19	6°				●	●
C25R-SDQCR/L11	31	25	16	200	35	24	4°	●	●			
C25S-SDQCR/L11	31	25	16	250	35	24	4°	●	●			

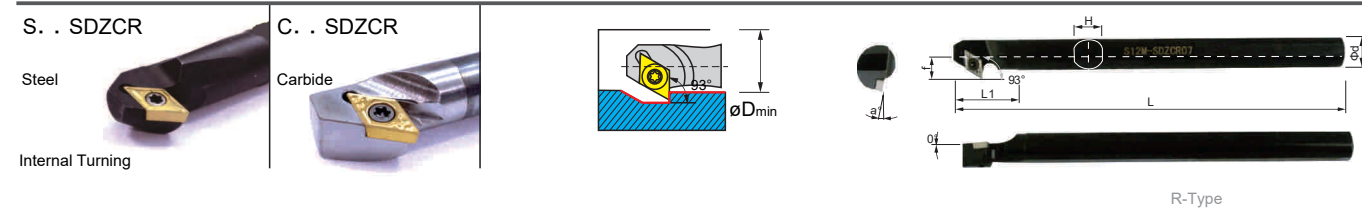

Ordering code	Dimensions							刀片 Insert	Screw	Wrench	Stock	
	ϕD_{min}	ϕd	f	L	L1	H	α°				R	L
S10K-SDZCR/L07	15	10	8.5	125	28	9	12°	DC..0702..	230074	230054	●	●
S12M-SDZCR/L07	18	12	9.5	150	30	11	10°				●	●
S16Q-SDZCR/L07	24	16	11.5	180	30	15	8°				●	●
S16Q-SDZCR/L11	25	16	13.3	180	35	15	10°				●	●
S20R-SDZCR/L11	28	20	14.5	200	40	19	8°				●	●
S25S-SDZCR/L11	34	25	17	250	45	24	6°	DC..11T3..	230090	230057	●	●
S32T-SDZCR/L11	38	32	20.5	300	50	30	4°				●	●

Carbide Steel Shock-Proof Toolholder(Shock-Proof Effect > 8 Times Toolholder Diameter)

C10M-SDZCR/L07	14	10	8.5	150	15	9	12°	DC..0702..	230074	230054	●	●
C12M-SDZCR/L07	17	12	10.5	150	20	11	10°				●	●
C16R-SDZCR/L07	21	16	12.5	200	25	15	8°				●	●
C20R-SDZCR/L11	26	20	15.5	200	30	19	8°				●	●
C20S-SDZCR/L11	26	20	15.5	250	30	19	8°				●	●
C25R-SDZCR/L11	33	25	18	200	35	24	6°	DC..11T3..	230090	230057	●	●
C25S-SDZCR/L11	33	25	18	250	35	24	6°				●	●

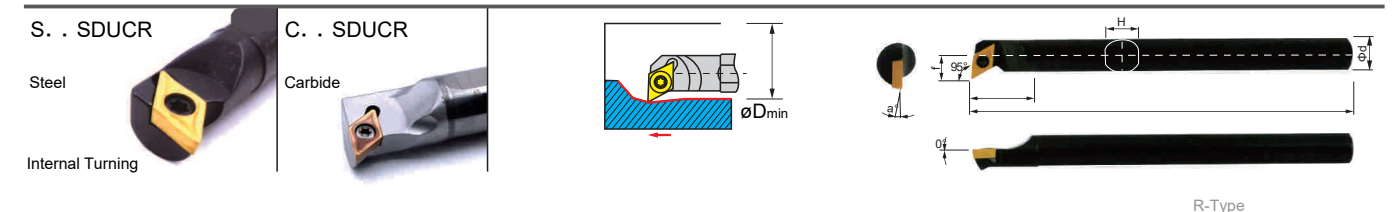

Ordering code	Dimensions							刀片 Insert	Screw	Wrench	Stock	
	ϕD_{min}	ϕd	f	L	L1	H	α°				R	L
S08K-SDUCR/L07	13	8	6.5	125	20	7	12°	DC..0702..	230074	230054	●	●
S10K-SDUCR/L07	15	10	8	125	25	9	10°				●	●
S12M-SDUCR/L07	17	12	9	150	28	11	8°				●	●
S14N-SDUCR/L07	17	14	9	160	28	13	8°				●	●
S16Q-SDUCR/L07	22	16	11	180	30	15	6°				●	●
S16Q-SDUCR/L11	22	16	11	180	30	15	6°	DC..11T3..	230090	230057	●	●
S18Q-SDUCR/L11	24	18	13	180	40	17	6°				●	●
S20R-SDUCR/L11	32	20	16	200	40	19	6°				●	●
S25S-SDUCR/L11	39	25	20	150	40	24	4°				●	●
S32T-SDUCR/L11	50	32	24	300	45	30	4°				●	●

Carbide Steel Shock-Proof Toolholder(Shock-Proof Effect > 8 Times Toolholder Diameter)

C10M-SDUCR/L07	13	10	7	150	15	9	10°	DC..0702..	230074	230054	●	●
C12M-SDUCR/L07	16	12	9	150	20	11	8°				●	●
C12Q-SDUCR/L07	16	12	9	180	20	11	8°				●	●
C14M-SDUCR/L07	18	14	10	150	25	13	8°				●	●
C16M-SDUCR/L07	20	16	11	150	25	15	6°				●	●
C16R-SDUCR/L07	20	16	11	200	25	15	6°	DC..11T3..	230090	230057	●	●
C16M-SDUCR/L11	20	16	11	150	25	15	6°				●	●
C16R-SDUCR/L11	20	16	11	200	25	15	6°				●	●
C20R-SDUCR/L11	23	20	12.5	200	30	19	6°				●	●
C20S-SDUCR/L11	23	20	12.5	250	30	19	6°				●	●
C25R-SDUCR/L11	31	25	16	200	35	24	4°	●	●			
C25S-SDUCR/L11	31	25	16	250	35	24	4°	●	●			

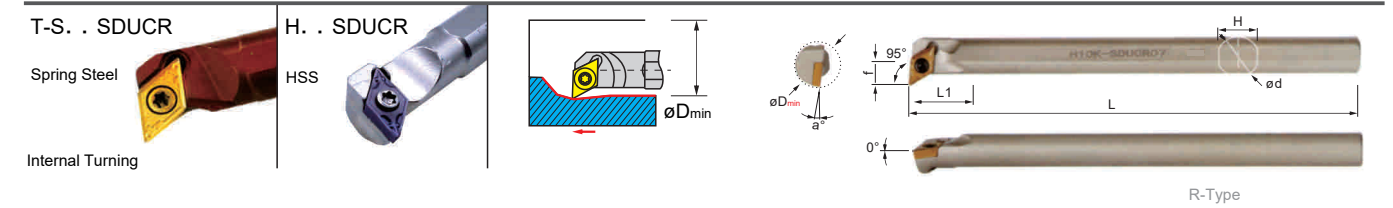

Spring Steel Shock-Proof Toolholder (Shock-Proof Effect > 4 Times Toolholder Diameter)

Ordering code	Dimensions							刀片 Insert	Screw	Wrench	Stock	
	ϕD_{min}	ϕd	f	L	L1	H	α°				R	L
T-S08K-SDUCR/L07	13	8	6.5	125	20	7	12°	DC..0702..	230074	230054	●	●
T-S10K-SDUCR/L07	15	10	8	125	25	9	10°				●	●
T-S12M-SDUCR/L07	17	12	9	150	28	11	8°				●	●
T-S14N-SDUCR/L07	17	14	9	160	28	13	8°				●	●
T-S16Q-SDUCR/L07	22	16	11	180	30	15	6°				●	●
T-S16Q-SDUCR/L11	22	16	11	180	30	15	6°	DC..11T3..	230090	230057	●	●
T-S18Q-SDUCR/L11	24	18	13	180	40	17	6°				●	●
T-S20R-SDUCR/L11	32	20	16	200	40	19	6°				●	●
T-S25S-SDUCR/L11	39	25	20	150	40	24	4°				●	●

High-Speed Steel Shock-Proof Toolholder (Shock-Proof Effect > 5 Times Toolholder Diameter)

H08K-SDUCR/L07	13	8	6.5	125	20	7	12°	DC..0702..	230074	230054	●	●
H10K-SDUCR/L07	15	10	8	125	25	9	10°				●	●
H12M-SDUCR/L07	17	12	9	150	28	11	8°				●	●
H14N-SDUCR/L07	17	14	9	160	28	13	8°				●	●
H16Q-SDUCR/L07	22	16	11	180	30	15	6°				●	●
H16Q-SDUCR/L11	22	16	11	180	30	15	6°	DC..11T3..	230090	230057	●	●
H18Q-SDUCR/L11	24	18	13	180	40	17	6°				●	●
H20R-SDUCR/L11	32	20	16	200	40	19	6°				●	●
H25S-SDUCR/L11	39	25	20	150	40	24	4°				●	●

S Type Internal Turning Tool

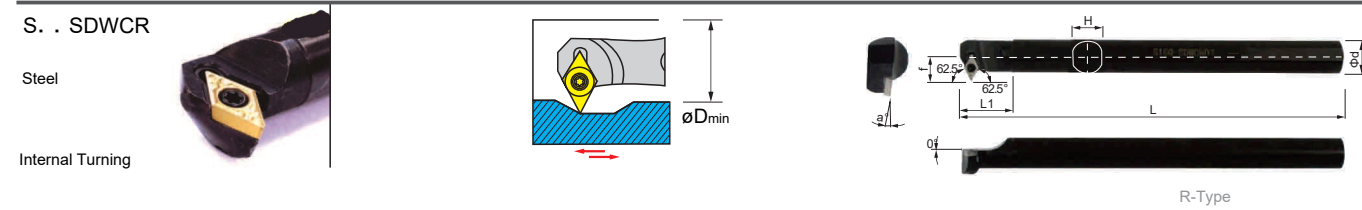

Ordering code	Dimensions							刀片 Insert	Screw	Wrench	Stock			
	ϕD_{min}	ϕd	f	L	L1	H	α°				R	L		
S10K-SDWCR/L07	16	10	10	125	20	9	10°	DC..0702..	230074	230054	•	•		
S12M-SDWCR/L07	19	12	10.5	150	28	11	10°				•	•		
S14N-SDWCR/L07	20	14	11.5	160	30	13	10°				•	•		
S16Q-SDWCR/L07	23	16	12.5	180	30	15	8°				•	•		
S20R-SDWCR/L07	26	20	14.5	200	30	19	6°				•	•		
S16Q-SDWCR/L11	24	16	15	180	25	15	8°	DC..11T3..	230090	230057	•	•		
S20R-SDWCR/L11	26	20	14.5	200	40	19	6°				•	•		
S25S-SDWCR/L11	32	25	17	250	45	24	4°				•	•		
S32T-SDWCR/L11	38	32	20	300	50	30	2°				•	•		
High-Speed Steel Shock-Proof Toolholder (Shock-Proof Effect > 5 Times Toolholder Diameter)														
H10K-SDWCR/L07	16	10	10	125	20	9	10°	DC..0702..	230074	230054	•	•		
H12M-SDWCR/L07	19	12	10.5	150	28	11	10°				•	•		
H14N-SDWCR/L07	20	14	11.5	160	30	13	10°				•	•		
H16Q-SDWCR/L07	23	16	12.5	180	30	15	8°				•	•		
H20R-SDWCR/L07	26	20	14.5	200	30	19	6°				•	•		
H16Q-SDWCR/L11	24	16	15	180	25	15	8°	DC..11T3..	230090	230057	•	•		
H20R-SDWCR/L11	26	20	14.5	200	40	19	6°				•	•		
H25S-SDWCR/L11	32	25	17	250	45	24	4°				•	•		
High-Speed Steel Shock-Proof Toolholder (Shock-Proof Effect > 8 Times Toolholder Diameter)														
C12M-SSKCR/L09	16	12	8.5	150	30	11	12°				SC..09T3..	230090	230057	•
C14N-SSKCR/L09	19	14	9.5	160	30	13	12°	•	•					
C16Q-SSKCR/L09	20	16	10.5	180	30	15	10°	•	•					
C18Q-SSKCR/L09	22	18	11.5	180	40	17	10°	•	•					
C20R-SSKCR/L09	25	20	12.5	200	40	19	8°	•	•					
C25S-SSKCR/L09	31	25	15	250	40	24	6°	•	•					
High-Speed Steel Shock-Proof Toolholder (Shock-Proof Effect > 5 Times Toolholder Diameter)														
H12M-SSKCR/L09	16	12	8.5	150	30	11	12°	SC..09T3..	230090	230057	•	•		
H14N-SSKCR/L09	19	14	9.5	160	30	13	12°				•	•		
H16Q-SSKCR/L09	20	16	10.5	180	30	15	10°				•	•		
H18Q-SSKCR/L09	22	18	11.5	180	40	17	10°				•	•		
H20R-SSKCR/L09	25	20	12.5	200	40	19	8°				•	•		
H25S-SSKCR/L09	31	25	15	250	40	24	6°	•	•					

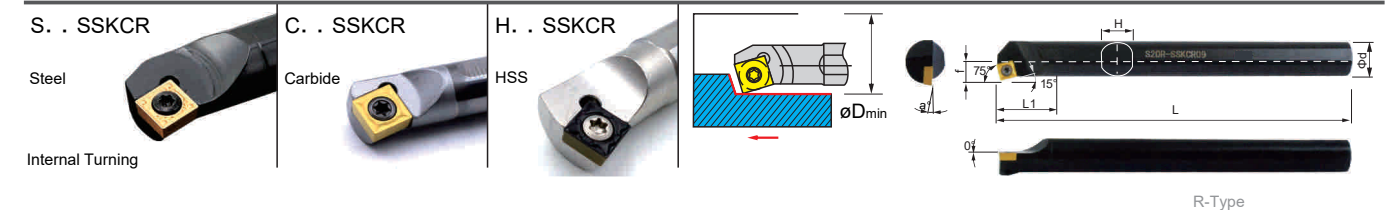

Ordering code	Dimensions							刀片 Insert	Screw	Wrench	Stock	
	ϕD_{min}	ϕd	f	L	L1	H	α°				R	L
S12M-SSKCR/L09	16	12	8.5	150	30	11	12°	SC..09T3..	230090	230057	•	•
S14N-SSKCR/L09	19	14	9.5	160	30	13	12°				•	•
S16Q-SSKCR/L09	20	16	10.5	180	30	15	10°				•	•
S18Q-SSKCR/L09	22	18	11.5	180	40	17	10°				•	•
S20R-SSKCR/L09	25	20	12.5	200	40	19	8°				•	•
S25S-SSKCR/L09	31	25	15	250	40	24	6°	•	•			
Carbide Steel Shock-Proof Toolholder (Shock-Proof Effect > 8 Times Toolholder Diameter)												
C12M-SSKCR/L09	16	12	8.5	150	30	11	12°	SC..09T3..	230090	230057	•	•
C14N-SSKCR/L09	19	14	9.5	160	30	13	12°				•	•
C16Q-SSKCR/L09	20	16	10.5	180	30	15	10°				•	•
C18Q-SSKCR/L09	22	18	11.5	180	40	17	10°				•	•
C20R-SSKCR/L09	25	20	12.5	200	40	19	8°				•	•
C25S-SSKCR/L09	31	25	15	250	40	24	6°	•	•			
High-Speed Steel Shock-Proof Toolholder (Shock-Proof Effect > 5 Times Toolholder Diameter)												
H12M-SSKCR/L09	16	12	8.5	150	30	11	12°	SC..09T3..	230090	230057	•	•
H14N-SSKCR/L09	19	14	9.5	160	30	13	12°				•	•
H16Q-SSKCR/L09	20	16	10.5	180	30	15	10°				•	•
H18Q-SSKCR/L09	22	18	11.5	180	40	17	10°				•	•
H20R-SSKCR/L09	25	20	12.5	200	40	19	8°				•	•
H25S-SSKCR/L09	31	25	15	250	40	24	6°	•	•			

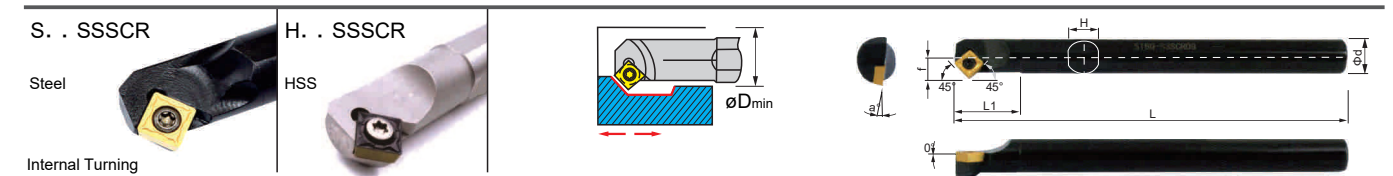

Ordering code	Dimensions							刀片 Insert	Screw	Wrench	Stock	
	ϕD_{min}	ϕd	f	L	L1	H	α°				R	L
S12M-SSSCR/L09	16	12	8.5	150	30	11	12°	SC..09T3..	230090	230057	•	•
S14N-SSSCR/L09	19	14	9.5	160	30	13	12°				•	•
S16Q-SSSCR/L09	20	16	11.5	180	35	15	10°				•	•
S18Q-SSSCR/L09	22	18	12.5	180	40	17	10°				•	•
S20R-SSSCR/L09	26	20	13.5	200	40	19	8°				•	•
S25S-SSSCR/L09	32	25	16	250	40	24	6°	•	•			
S32T-SSSCR/L09	38	32	19.5	300	45	30	4°	•	•			
High-Speed Steel Shock-Proof Toolholder (Shock-Proof Effect > 5 Times Toolholder Diameter)												
H12M-SSSCR/L09	16	12	8.5	150	30	11	12°	SC..09T3..	230090	230057	•	•
H14N-SSSCR/L09	19	14	9.5	160	30	13	12°				•	•
H16Q-SSSCR/L09	20	16	11.5	180	35	15	10°				•	•
H18Q-SSSCR/L09	22	18	12.5	180	40	17	10°				•	•
H20R-SSSCR/L09	26	20	13.5	200	40	19	8°				•	•
H25S-SSSCR/L09	32	25	16	250	40	24	6°	•	•			

S Type Internal Turning Tool

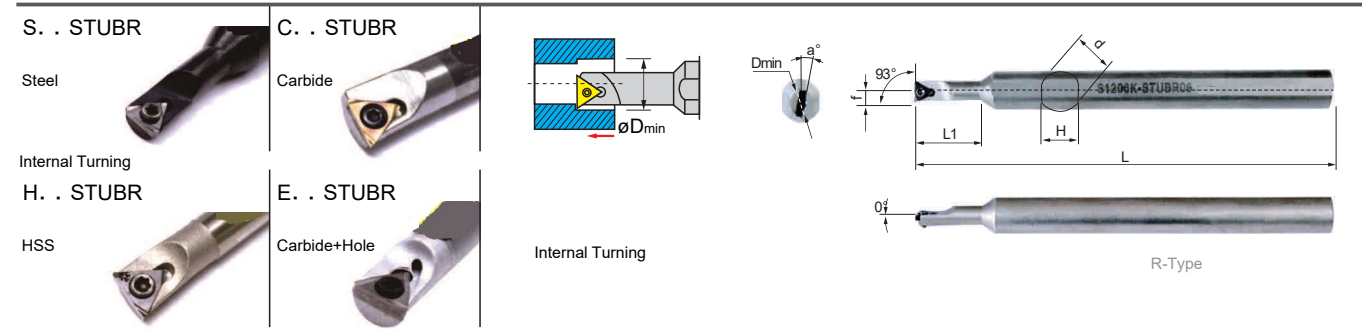

Ordering code	Dimensions							Insert	Screw	Wrench	Stock	
	ϕD_{min}	ϕd	f	L	L1	H	α°				R	L
S06H-STUBR/L06	7	6	4	100	15	5.4	12°	TB..0601..	230066	230052	•	•
S0806H-STUBR/L06	7	8	3.5	110	20	7	12°				•	•
S1006K-STUBR/L06	7	10	3.5	125	20	9	12°				•	•
S1207K-STUBR/L06	8	12	4	125	25	11	12°				•	•
S1607M-STUBR/L06	7	16	4	125	20	15	12°				•	•
S1607M-STUBR/L06	8	16	4	150	25	15	12°				•	•
Carbide Steel Shock-Proof Toolholder(Shock-Proof Effect > 8 Times Toolholder Diameter)												
C06J-STUBR/L06-07	7	6	3.5	110	10	5.5	12°	TB..0601..	230066	230052	•	•
C07J-STUBR/L06-08	8	7	4	110	12	6	12°				•	•
C08K-STUBR/L06-09	9	8	4.5	125	15	7	12°				•	•
Carbide Steel Shock-Proof Toolholder(Shock-Proof Effect > 8 Times Toolholder Diameter)												
C0807K-STUBR06-08	8	8	4	125	15	7	12°	TB..0601..	230066	230052	•	•
Carbide Steel Shock-Proof Hollow Toolholder(Shock-Proof Effect > 8 Times Toolholder Diameter)												
E06J-STUBR06/L-07	7	6	3.5	110	10	5	12°	TB..0601..	230066	230052	•	•
High-Speed Steel Shock-Proof Toolholder (Shock-Proof Effect > 5 Times Toolholder Diameter)												
H06H-STUBR/L06	7	6	4	100	15	5.4	12°	TB..0601..	230066	230052	•	•
H0806H-STUBR/L06	7	8	3.5	110	20	7	12°				•	•
H1006K-STUBR/L06	7	10	3.5	125	20	9	12°				•	•
H1207K-STUBR/L06	8	12	4	125	25	11	12°				•	•
H1607M-STUBR/L06	7	16	4	125	20	15	12°				•	•
H1607M-STUBR/L06	8	16	4	150	25	15	12°				•	•

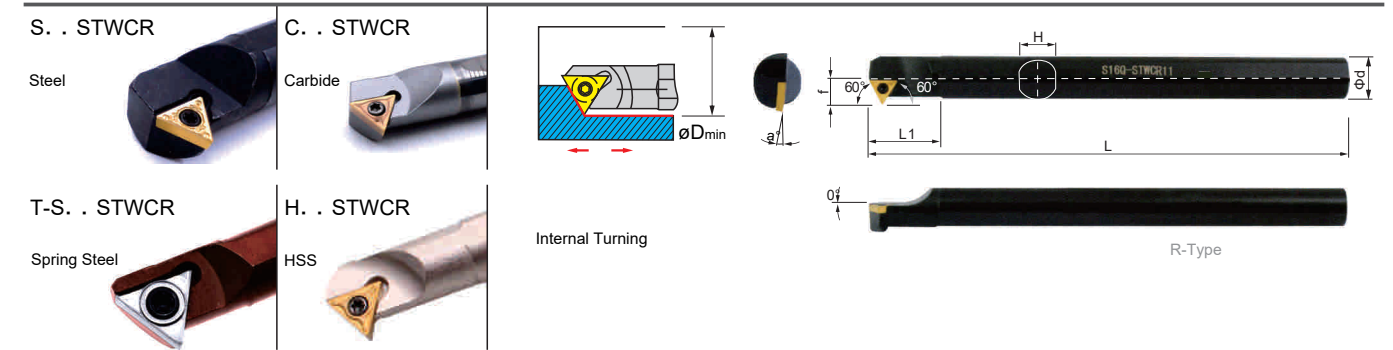

Ordering code	Dimensions							Insert	Screw	Wrench	Stock				
	ϕD_{min}	ϕd	f	L	L1	H	α°				R	L			
S08K-STWCR/L09	11	8	5.5	125	25	7	12°	TC..0902..	230072	230052	•	•			
S10K-STWCR/L11	14	10	8	125	25	9	10°	TC..1102..	230075	230054	•	•			
S12M-STWCR/L11	16	12	9	150	30	11	8°				•	•			
S16Q-STWCR/L11	20	16	11	180	30	15	6°				•	•			
S20R-STWCR/L11	25	20	13	200	35	19	4°				•	•			
S20R-STWCR/L16	25	20	13	200	35	19	4°				TC..16T3..	230092	230057	•	•
S25S-STWCR/L16	32	25	15	250	40	24	2°				TC..16T3..	230092	230057	•	•
Carbide Steel Shock-Proof Toolholder(Shock-Proof Effect > 8 Times Toolholder Diameter)															
C08K-STWCR/L09	11	8	5.5	125	15	7	12°	TC..0902..	230072	230052	•	•			
C10M-STWCR/L11	14	10	8	150	20	9	10°	TC..1102..	230075	230054	•	•			
C12M-STWCR/L11	16	12	9	150	20	11	8°				•	•			
C16R-STWCR/L11	20	16	11	200	25	15	6°				•	•			
C20R-STWCR/L11	25	20	13	200	30	19	4°				•	•			
C20R-STWCR/L11	25	20	13	200	30	19	4°				•	•			
C20S-STWCR/L11	25	20	13	250	30	19	4°				•	•			
Spring Steel Shock-Proof Toolholder (Shock-Proof Effect > 4 Times Toolholder Diameter)															
T-S08K-STWCR/L09	11	8	5.5	125	25	7	12°	TC..0902..	230072	230052	•	•			
T-S10K-STWCR/L11	14	10	8	125	25	9	10°	TC..1102..	230075	230054	•	•			
T-S12M-STWCR/L11	16	12	9	150	30	11	8°				•	•			
T-S16Q-STWCR/L11	20	16	11	180	30	15	6°				•	•			
T-S20R-STWCR/L11	25	20	13	200	35	19	4°				•	•			
T-S20R-STWCR/L16	25	20	13	200	35	19	4°				TC..16T3..	230092	230057	•	•
T-S25S-STWCR/L16	32	25	15	250	40	24	2°				TC..16T3..	230092	230057	•	•
High-Speed Steel Shock-Proof Toolholder (Shock-Proof Effect > 5 Times Toolholder Diameter)															
H08K-STWCR/L09	11	8	5.5	125	25	7	12°	TC..0902..	230072	230052	•	•			
H10K-STWCR/L11	14	10	8	125	25	9	10°	TC..1102..	230075	230054	•	•			
H12M-STWCR/L11	16	12	9	150	30	11	8°				•	•			
H16Q-STWCR/L11	20	16	11	180	30	15	6°				•	•			
H20R-STWCR/L11	25	20	13	200	35	19	4°				•	•			
H20R-STWCR/L16	25	20	13	200	35	19	4°				TC..16T3..	230092	230057	•	•
H25S-STWCR/L16	32	25	15	250	40	24	2°				TC..16T3..	230092	230057	•	•

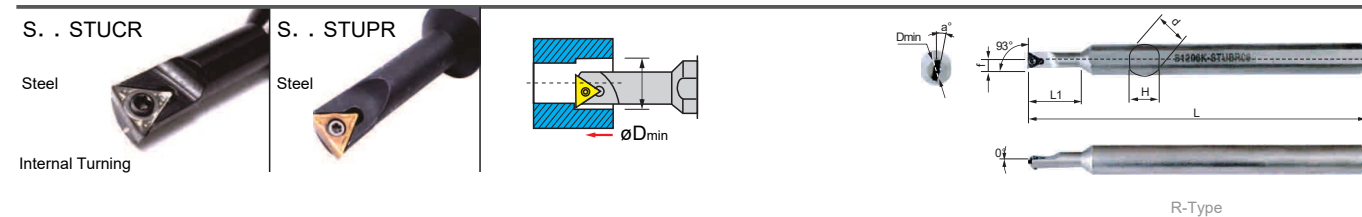

Ordering code	Dimensions							Insert	Screw	Wrench	Stock	
	ϕD_{min}	ϕd	f	L	L1	H	α°				R	L
S07K-STUPR/L08-A12	9	12	4.5	125	25	11	12°	TP..0802..	230072	230052	•	•
S08M-STUPR/L08-A16	10	16	5	150	28	15	13°				•	•
S10M-STUPR/L11-A16	12	16	6	150	30	15	12°				•	•
S12M-STUPR/L11-A16	14	16	7	150	33	15	10°	TP..1103..	230078	230054	•	•
S08K-STUCR/L09-A12	10	12	5.5	125	28	11	15°	TC..0902..	230074	230054	•	•
S08M-STUCR/L09-A16	10	16	5.5	150	28	15	10°				•	•
S10M-STUCR/L11-A16	12	16	6	150	30	15	12°				•	•
S12M-STUCR/L11-A16	14	16	7	150	33	15	10°	TC..1102..	230074	230054	•	•

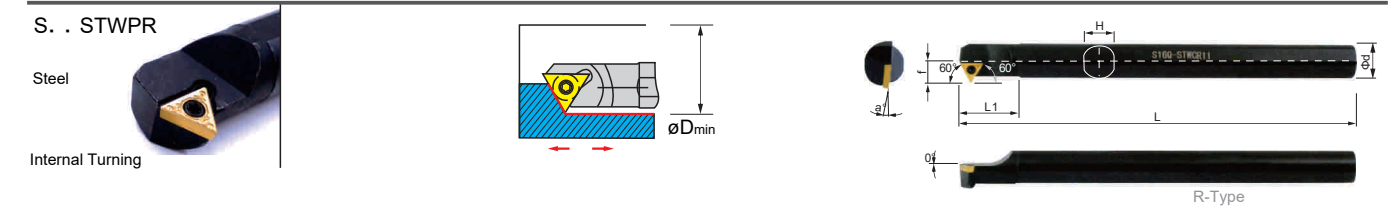

Ordering code	Dimensions							Insert	Screw	Wrench	Stock	
	ϕD_{min}	ϕd	f	L	L1	H	α°				R	L
S08K-STWPR/L09	11	8	5.5	125	25	7	12°	TP..0902..	230074	230054	•	•
S10K-STWPR/L11	14	10	8	125	25	9	10°	TP..1102..	230078	230056	•	•
S12M-STWPR/L11	16	12	9	150	30	11	8°				•	•
S16Q-STWPR/L11	20	16	11	180	30	15	6°				•	•
S20R-STWPR/L11	25	20	13	200	35	19	4°				•	•

S Type Internal Turning Tool

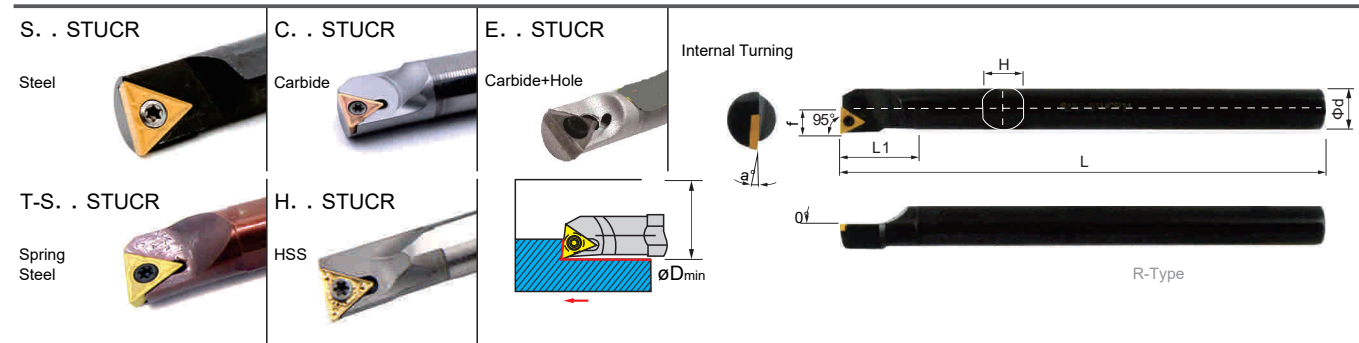

Ordering code	Dimensions							Insert	Screw	Wrench	Stock	
	ØD _{min}	ød	f	L	L1	H	α°				R	L
S08K-STUCR/L09B	10	8	5	125	23	7	15°	TC..0902..	230074	230054	•	•
S10K-STUCR/L09B	12	10	6	125	24	9	13°				•	•
S08K-STUCR/L09	10	8	5	125	23	7	15°				•	•
S10K-STUCR/L09	12	10	6	125	24	9	13°	TC..0902..	230072	230052	•	•
S12M-STUCR/L09	14	12	7	150	27	11	10°				•	•
S10K-STUCR/L11	12	10	6	125	24	9	12°				•	•
S12M-STUCR/L11	14	12	7	150	27	11	10°	TC..1102..	230074	230054	•	•
S14Q-STUCR/L11	16	14	8	180	30	13	9°				•	•
S16Q-STUCR/L11	18	16	9	180	30	15	8°				•	•
S20R-STUCR/L11	23	20	11	200	35	19	6°	TC..16T3..	230092	230057	•	•
S25S-STUCR/L11	28	25	13.5	250	40	24	4°				•	•
S16Q-STUCR/L16	18	16	9.5	180	28	15	10°				•	•
S20R-STUCR/L16	23	20	11.5	200	40	19	8°	TC..16T3..	230092	230057	•	•
S25S-STUCR/L16	28	25	14	250	40	24	6°				•	•
S32T-STUCR/L16	35	32	17.5	300	45	30	4°				•	•

Carbide Steel Shock-Proof Toolholder (Shock-Proof Effect > 8 Times Toolholder Diameter)

C08K-STUCR/L09	10	8	5	125	12	7	15°	TC..0902..	230072	230052	•	•
C10M-STUCR/L09	12	10	6	150	15	9	13°				•	•
C12M-STUCR/L09	14	12	7	150	20	11	10°				•	•
C12Q-STUCR/L09	14	12	7	180	20	11	10°	TC..1102..	230074	230054	•	•
C10M-STUCR/L11	12	10	6	150	15	9	12°				•	•
C12M-STUCR/L11	14	12	7	150	20	11	10°				•	•
C12Q-STUCR/L11	14	12	7	180	20	11	10°	TC..1102..	230074	230054	•	•
C14M-STUCR/L11	16	14	8	150	20	13	9°				•	•
C16M-STUCR/L11	18	16	9	150	25	15	8°				•	•
C16R-STUCR/L11	18	16	9	200	25	15	8°	TC..1102..	230074	230054	•	•
C20R-STUCR/L11	22	20	11	200	30	19	6°				•	•
C20S-STUCR/L11	22	20	11	250	30	19	6°				•	•
C25R-STUCR/L11	32	25	16	200	35	24	4°	TC..1102..	230074	230054	•	•
C25S-STUCR/L11	32	25	16	250	35	24	4°				•	•

Carbide Steel Shock-Proof Hollow Toolholder (Shock-Proof Effect > 8 Times Toolholder Diameter)

E08K-STUCR/L09	10	8	5	125	12	7	15°	TC..0902..	230072	230052	•	•
E10M-STUCR/L11	12	10	6	150	15	9	13°				•	•
E12M-STUCR/L11	14	12	7	150	20	11	10°				•	•
E12Q-STUCR/L11	14	12	7	180	20	11	10°	TC..1102..	230074	230054	•	•
E16R-STUCR/L11	18	16	9	200	25	15	8°				•	•
E20R-STUCR/L11	22	20	11	200	30	19	6°				•	•
E20S-STUCR/L11	22	20	11	250	35	19	6°	TC..1102..	230074	230054	•	•

Spring Steel Shock-Proof Toolholder (Shock-Proof Effect > 4 Times Toolholder Diameter)

T-S08K-STUCR/L09	10	8	5	125	23	7	15°	TC..0902..	230074	230054	•	•
T-S10K-STUCR/L09	12	10	6	125	24	9	13°				•	•
T-S12M-STUCR/L09	14	12	7	150	27	11	10°				•	•
T-S10K-STUCR/L11	12	10	6	125	24	9	12°	TC..1102..	230074	230054	•	•
T-S12M-STUCR/L11	14	12	7	150	27	11	10°				•	•
T-S14Q-STUCR/L11	16	14	8	180	30	13	9°				•	•
T-S16Q-STUCR/L11	18	16	9	180	30	15	8°	TC..1102..	230074	230054	•	•
T-S20R-STUCR/L11	23	20	11	200	35	19	6°				•	•
T-S25S-STUCR/L11	28	25	13.5	250	40	24	4°				•	•

High-Speed Steel Shock-Proof Toolholder (Shock-Proof Effect > 5 Times Toolholder Diameter)

H08K-STUCR/L09	10	8	5	125	23	7	15°	TC..0902..	230074	230054	•	•
H10K-STUCR/L09	12	10	6	125	24	9	13°				•	•
H12M-STUCR/L09	14	12	7	150	27	11	10°				•	•
H10K-STUCR/L11	12	10	6	125	24	9	12°	TC..1102..	230074	230054	•	•
H12M-STUCR/L11	14	12	7	150	27	11	10°				•	•
H14Q-STUCR/L11	16	14	8	180	30	13	9°				•	•
H16Q-STUCR/L11	18	16	9	180	30	15	8°	TC..1102..	230074	230054	•	•
H20R-STUCR/L11	23	20	11	200	35	19	6°				•	•
H25S-STUCR/L11	28	25	13.5	250	40	24	4°				•	•

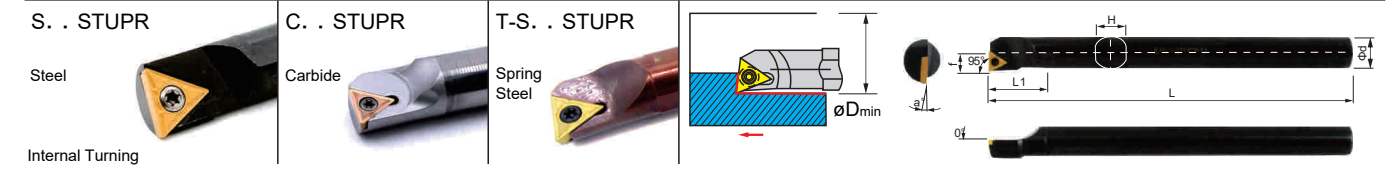

R-Type

Ordering code	Dimensions							Insert	Screw	Wrench	Stock	
	ØD _{min}	ød	f	L	L1	H	α°				R	L
S08K-STUPR/L08	10	8	5	125	20	7	15°	TP..0802..	230072	230052	•	•
S10K-STUPR/L08	11	10	6	125	20	9	13°				•	•
S08K-STUPR/L09	10.5	8	5.5	125	23	7	15°				•	•
S10K-STUPR/L09	13.5	10	6.5	125	24	9	13°	TP..0902..	230074	230054	•	•
S12M-STUPR/L09	16	12	7.5	150	27	11	10°				•	•
S10K-STUPR/L11	13.5	10	6.5	125	24	9	12°				•	•
S12M-STUPR/L11	16	12	7.5	150	27	11	10°	TP..1103..	230078	230056	•	•
S14Q-STUPR/L11	18	14	8.5	180	30	13	9°				•	•
S16Q-STUPR/L11	20	16	9.5	180	30	15	8°				•	•
S20R-STUPR/L11	25	20	11.5	200	35	19	6°	TP..1603..	230090	230057	•	•
S25S-STUPR/L11	31	25	14	250	40	24	4°				•	•
S20R-STUPR/L16	25	20	12	200	40	19	8°				•	•
S25S-STUPR/L16	31	25	14.5	250	40	24	6°	TP..1603..	230090	230057	•	•
S32T-STUPR/L16	39	32	18	300	45	30	4°				•	•

Carbide Steel Shock-Proof Toolholder (Shock-Proof Effect > 8 Times Toolholder Diameter)

C08K-STUPR/L09	10	8	5.5	125	15	7	15°	TP..0902..	230074	230054	•	•
C10M-STUPR/L09	12	10	6.5	150	15	9	13°				•	•
C12M-STUPR/L09	14	12	7.5	150	20	11	10°				•	•
C12Q-STUPR/L09	14	12	7.5	180	20	11	10°	TP..1103..	230078	230056	•	•
C10M-STUPR/L11	12	10	6.5	150	15	9	12°				•	•
C12M-STUPR/L11	14	12	7.5	150	20	11	10°				•	•
C12Q-STUPR/L11	14	12	7.5	180	20	11	10°	TP..1103..	230078	230056	•	•
C14M-STUPR/L11	16	14	8.5	150	20	13	9°				•	•
C16M-STUPR/L11	18	16	9.5	150	25	15	8°				•	•
C16R-STUPR/L11	18	16	9.5	200	25	15	6°	TP..1103..	230078	230056	•	•
C20R-STUPR/L11	22	20	11.5	200	30	19	4°				•	•
C20S-STUPR/L11	22	20	11.5	250	30	19	8°				•	•
S25R-STUPR/L11	32	25	16.5	200	35	24	6°	TP..1103..	230078	230057	•	•
S25S-STUPR/L11	32	25	16.5	250	35	24	4°				•	•

Carbide Steel Shock-Proof Hollow Toolholder (Shock-Proof Effect > 8 Times Toolholder Diameter)

E08K-STUPR/L09	10	8	5.5	125	15	7	15°	TP..0902..	230074	230054	•	•
E10M-STUPR/L11	12	10	6.5	150	15	9	13°				•	•
E12M-STUPR/L11	14	12	7.5	150	20	11	10°				•	•
E12Q-STUPR/L11	14	12	7.5	180	20	11	10°	TP..1103..	230078	230057	•	•
E16R-STUPR/L11	18	16	9.5	200	25	15	8°				•	•
E20R-STUPR/L11	22	20	11.5	200	30	19	6°				•	•
E20S-STUPR/L11	22	20	11.5	250	30	19	6°	TP..1103..	230078	230057	•	•

STUP 1102 type

S10K-STUPR/L1102	13.5	10	6.5	125	24	9	13°	TP..1102..	230078	230057	•	•
S12M-STUPR/L1102	16	12	7.5	150	27	11	10°				•	•
S14Q-STUPR/L1102	18	14	8.5	180	30	13	9°				•	•
S16Q-STUPR/L1102	20	16	9.5	180	30	15	8°	TP..1102..	230078	230057	•	•
S20R-STUPR/L1102	25	20	12	200	35	19	6°				•	•
S25S-STUPR/L1102	31	25	14.5	250	40	24	4°				•	•

Spring Steel Shock-Proof Toolholder (Shock-Proof Effect > 4 Times Toolholder Diameter)

T-S08K-STUPR/L09	10	8	5	125	23	7	15°	TP..0902..	230074	230054	•	•
T-S10K-STUPR/L09	12	10	6	125	24	9	13°				•	•
T-S12M-STUPR/L09	14	12	7	150	27	11	1					

S Type Internal Turning Tool

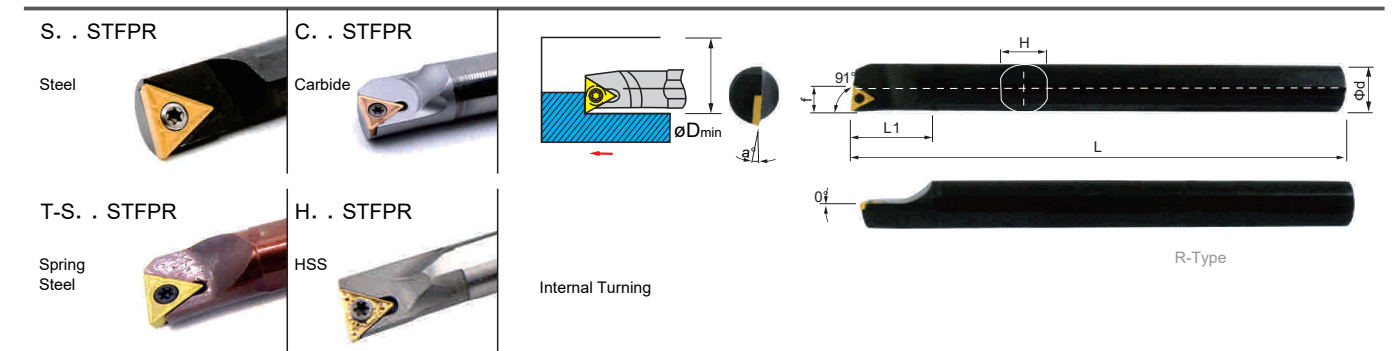
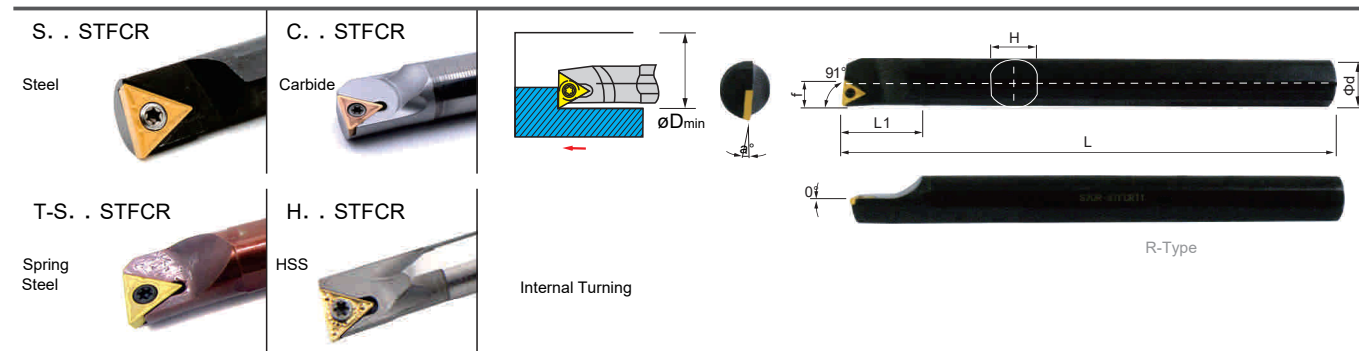

Ordering code	Dimensions							Insert	Screw	Wrench	Stock	
	ϕd	f	L	L1	H	α°	R				L	
S08K-STFCR/L09	10.5	8	5	125	23	7	15°	TC..0902..	230072	230052	•	•
S10K-STFCR/L09	13.5	10	6	125	24	9	13°				•	•
S12M-STFCR/L09	16	12	7	150	27	11	10°				•	•
S10K-STFCR/L11	13.5	10	6	125	24	9	12°	TC..1102..	230074	230054	•	•
S12M-STFCR/L11	16	12	7	150	27	11	10°				•	•
S14Q-STFCR/L11	18	14	8	180	30	13	9°				•	•
S16Q-STFCR/L11	20	16	9	180	30	15	8°				•	•
S20R-STFCR/L11	25	20	11	200	35	19	6°				•	•
S25S-STFCR/L11	31	25	13.5	250	40	24	4°	TC..16T3..	230092	230057	•	•
S20R-STFCR/L16	25	20	11.5	200	40	19	8°				•	•
S25S-STFCR/L16	31	25	14	250	40	24	6°				•	•
S32T-STFCR/L16	39	32	17.5	300	45	30	4°				•	•

Carbide Steel Shock-Proof Toolholder (Shock-Proof Effect > 8 Times Toolholder Diameter)

C08K-STFCR/L09	10	8	5	125	15	7	15°	TC..0902..	230072	230052	•	•
C10M-STFCR/L09	12	10	6	150	20	9	13°				•	•
C12M-STFCR/L09	14	12	7	150	20	11	10°				•	•
C12Q-STFCR/L09	14	12	7	180	20	11	12°				•	•
C10M-STFCR/L11	12	10	6	150	20	9	10°	TC..1102..	230074	230054	•	•
C12M-STFCR/L11	14	12	7	150	20	11	9°				•	•
C12Q-STFCR/L11	14	12	7	180	20	11	8°				•	•
C14M-STFCR/L11	16	14	8	150	25	13	6°				•	•
C16M-STFCR/L11	18	16	9	150	25	15	4°				•	•
C16R-STFCR/L11	18	16	9	200	25	15	8°				•	•
C20R-STFCR/L11	22	20	11	200	30	19	6°				•	•
C20S-STFCR/L11	22	20	11	250	30	19	6°				•	•

Spring Steel Shock-Proof Toolholder (Shock-Proof Effect > 4 Times Toolholder Diameter)

T-S08K-STFCR/L09	10	8	5	125	23	7	15°	TC..0902..	230074	230054	•	•
T-S10K-STFCR/L09	12	10	6	125	24	9	13°				•	•
T-S12M-STFCR/L09	14	12	7	150	27	11	10°				•	•
T-S10K-STFCR/L11	12	10	6	125	24	9	12°	TC..1102..	230074	230054	•	•
T-S12M-STFCR/L11	14	12	7	150	27	11	10°				•	•
T-S14Q-STFCR/L11	16	14	8	180	30	13	9°				•	•
T-S16Q-STFCR/L11	18	16	9	180	30	15	8°				•	•
T-S20R-STFCR/L11	23	20	11	200	35	19	6°				•	•
T-S25S-STFCR/L11	28	25	13.5	250	40	24	4°				•	•

High-Speed Steel Shock-Proof Toolholder (Shock-Proof Effect > 5 Times Toolholder Diameter)

H08K-STFCR/L09	10	8	5	125	23	7	15°	TC..0902..	230074	230054	•	•
H10K-STFCR/L09	12	10	6	125	24	9	13°				•	•
H12M-STFCR/L09	14	12	7	150	27	11	10°				•	•
H10K-STFCR/L11	12	10	6	125	24	9	12°	TC..1102..	230074	230054	•	•
H12M-STFCR/L11	14	12	7	150	27	11	10°				•	•
H14Q-STFCR/L11	16	14	8	180	30	13	9°				•	•
H16Q-STFCR/L11	18	16	9	180	30	15	8°				•	•
H20R-STFCR/L11	23	20	11	200	35	19	6°				•	•
H25S-STFCR/L11	28	25	13.5	250	40	24	4°				•	•

Ordering code	Dimensions							Insert	Screw	Wrench	Stock	
	ϕD_{min}	ϕd	f	L	L1	H	α°				R	L
S08K-STFPR/L09	10.5	8	5.5	125	23	7	15°	TP..0902..	230074	230054	•	•
S10K-STFPR/L09	13.5	10	6.5	125	24	9	13°				•	•
S12M-STFPR/L09	16	12	7.5	150	27	11	10°				•	•
S10K-STFPR/L11	13.5	10	6.5	125	24	9	12°	TP..1103..	230078	230056	•	•
S12M-STFPR/L11	16	12	7.5	150	27	11	10°				•	•
S14Q-STFPR/L11	18	14	8.5	180	30	13	9°				•	•
S16Q-STFPR/L11	20	16	9.5	180	30	15	8°				•	•
S20R-STFPR/L11	25	20	11.5	200	35	19	6°				•	•
S25S-STFPR/L11	31	25	14	250	40	24	4°	TP..1603..	230090	230057	•	•
S20R-STFPR/L16	25	20	12	200	40	19	8°				•	•
S25S-STFPR/L16	31	25	14.5	250	40	24	6°				•	•
S32T-STFPR/L16	39	32	18	300	45	30	4°				•	•

Carbide Steel Shock-Proof Toolholder (Shock-Proof Effect > 8 Times Toolholder Diameter)

C08K-STFPR/L09	10	8	5.5	125	15	7	15°	TP..0902..	230074	230054	•	•
C10M-STFPR/L09	12	10	6.5	150	20	9	13°				•	•
C12M-STFPR/L09	14	12	7.5	150	20	11	10°				•	•
C12Q-STFPR/L09	14	12	7.5	180	20	11	12°				•	•
C10M-STFPR/L11	12	10	6.5	150	20	9	10°	TP..1103..	230078	230056	•	•
C12M-STFPR/L11	14	12	7.5	150	20	11	9°				•	•
C12Q-STFPR/L11	14	12	7.5	180	20	11	8°				•	•
C14M-STFPR/L11	16	14	8.5	150	25	13	6°				•	•
C16M-STFPR/L11	18	16	9.5	150	25	15	4°				•	•
C16R-STFPR/L11	18	16	9.5	200	25	15	8°				•	•
C20R-STFPR/L11	22	20	11.5	200	30	19	6°				•	•
C20S-STFPR/L11	22	20	11.5	250	30	19	6°				•	•
C25S-STFPR/L16	32	25	16	250	35	24	4°				•	•

Spring Steel Shock-Proof Toolholder (Shock-Proof Effect > 4 Times Toolholder Diameter)

T-S08K-STFPR/L09	10	8	5	125	23	7	15°	TP..0902..	230074	230054	•	•
T-S10K-STFPR/L09	12	10	6	125	24	9	13°				•	•
T-S12M-STFPR/L09	14	12	7	150	27	11	10°				•	•
T-S10K-STFPR/L11	12	10	6	125	24	9	12°	TP..1103..	230078	230056	•	•
T-S12M-STFPR/L11	14	12	7	150	27	11	10°				•	•
T-S14Q-STFPR/L11	16	14	8	180	30	13	9°				•	•
T-S16Q-STFPR/L11	18	16	9	180	30	15	8°				•	•
T-S20R-STFPR/L11	23	20	11	200	35	19	6°				•	•
T-S25S-STFPR/L11	28	25	13.5	250	40	24	4°				•	•

High-Speed Steel Shock-Proof Toolholder (Shock-Proof Effect > 5 Times Toolholder Diameter)

H08K-STFPR/L09	10	8	5	125	23	7	15°	TP..0902..	230074	230054	•	•
H10K-STFPR/L09	12	10	6	125	24	9	13°				•	•
H12M-STFPR/L09	14	12	7	150	27	11	10°				•	•
H10K-STFPR/L11	12	10	6	125	24	9	12°	TP..1103..	230078	230056	•	•
H12M-STFPR/L11	14	12	7	150	27	11	10°				•	•
H14Q-STFPR/L11	16	14	8	180	30	13	9°				•	•
H16Q-STFPR/L11	18	16	9	180	30	15	8°				•	•
H20R-STFPR/L11	23	20	11	200	35	19	6°				•	•
H25S-STFPR/L11	28	25	13.5	250	40	24	4°				•	•

S Type Internal Turning Tool

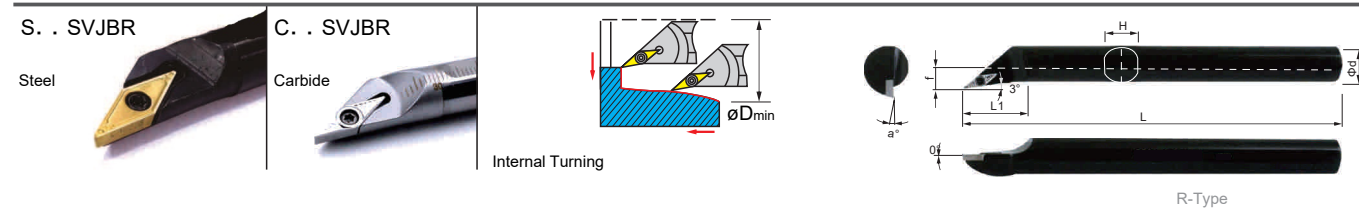

Ordering code	Dimensions							Insert	Screw	Wrench	Stock	
	δD_{min}	δd	f	L	L1	H	α°				R	L
S08H-SVJBR/L08	10	8	5	100	20	7	15°	VB..0802..	230066	230052	•	•
S10K-SVJBR/L08	12	10	6	125	25	9	15°				•	•
S10K-SVJBR/L11	12	10	6	125	25	9	12°				•	•
S12M-SVJBR/L11	14	12	7	150	30	11	12°	VB..1103..	230075	230054	•	•
S16Q-SVJBR/L11	22	16	11.5	180	40	15	10°				•	•
S20R-SVJBR/L11	27	20	13.5	200	45	19	8°				•	•
S20R-SVJBR/L16	27	20	13.5	200	50	19	10°	VB..1604..	230092	230057	•	•
S25S-SVJBR/L16	32	25	16	250	50	24	8°				•	•
S32T-SVJBR/L16	40	32	19.5	300	60	30	10°				•	•
S40T-SVJBR/L16	50	40	23.5	300	65	38	8°	•	•			

Carbide Steel Shock-Proof Toolholder(Shock-Proof Effect > 8 Times Toolholder Diameter)

C06J-SVJBR/L08	8.5	6	3.25	110	15	5	15°	VB..0802..	230066	230052	•	•
C08K-SVJBR/L08	10	8	5	125	15	7	15°				•	•
C10M-SVJBR/L08	12	10	6	150	20	9	15°				•	•
C10M-SVJBR/L11	12	10	6	150	20	9	12°	VB..1103..	230075	230054	•	•
C12M-SVJBR/L11	14	12	7	150	20	11	12°				•	•
C12Q-SVJBR/L11	14	12	7	180	20	11	12°				•	•
C16R-SVJBR/L11	18	16	9	200	25	15	10°	VB..1604..	230092	230057	•	•
C20R-SVJBR/L11	22	20	11	200	30	19	8°				•	•
C20S-SVJBR/L11	22	20	11	250	30	19	10°				•	•
C25S-SVJBR/L16	28	25	14	200	35	24	8°	•	•			

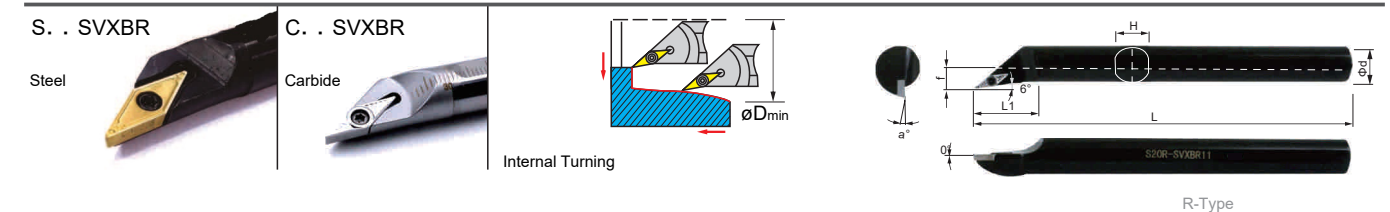

Ordering code	Dimensions							Insert	Screw	Wrench	Stock	
	δD_{min}	δd	f	L	L1	H	α°				R	L
S08H-SVXBR/L08	10	8	5	100	20	7	15°	VB..0802..	230066	230052	•	•
S10K-SVXBR/L08	12	10	6	125	25	9	15°				•	•
S10K-SVXBR/L11	12	10	6	125	25	9	12°				•	•
S12M-SVXBR/L11	14	12	7	150	30	11	12°	VB..1103..	230075	230054	•	•
S16Q-SVXBR/L11	22	16	11.5	180	40	15	10°				•	•
S20R-SVXBR/L11	27	20	13.5	200	45	19	8°				•	•
S20R-SVXBR/L16	27	20	13.5	200	50	19	10°	VB..1604..	230092	230057	•	•
S25S-SVXBR/L16	32	25	16	250	50	24	8°				•	•
S32T-SVXBR/L16	40	32	19.5	300	60	30	10°				•	•
S40T-SVXBR/L16	50	40	23.5	300	65	38	8°	•	•			

Carbide Steel Shock-Proof Toolholder(Shock-Proof Effect > 8 Times Toolholder Diameter)

C06J-SVXBR/L08	8.5	6	3.25	110	15	5	15°	VB..0802..	230066	230052	•	•
C08K-SVXBR/L08	10	8	5	125	15	7	15°				•	•
C10M-SVXBR/L08	12	10	6	150	20	9	15°				•	•
C10M-SVXBR/L11	12	10	6	150	20	9	12°	VB..1103..	230075	230054	•	•
C12M-SVXBR/L11	14	12	7	150	20	11	12°				•	•
C12Q-SVXBR/L11	14	12	7	180	20	11	12°				•	•
C16R-SVXBR/L11	18	16	9	200	25	15	10°	VB..1604..	230092	230057	•	•
C20R-SVXBR/L11	22	20	11	200	30	19	8°				•	•
C20S-SVXBR/L11	22	20	11	250	30	19	10°				•	•
C25S-SVXBR/L16	28	25	14	200	35	24	8°	•	•			

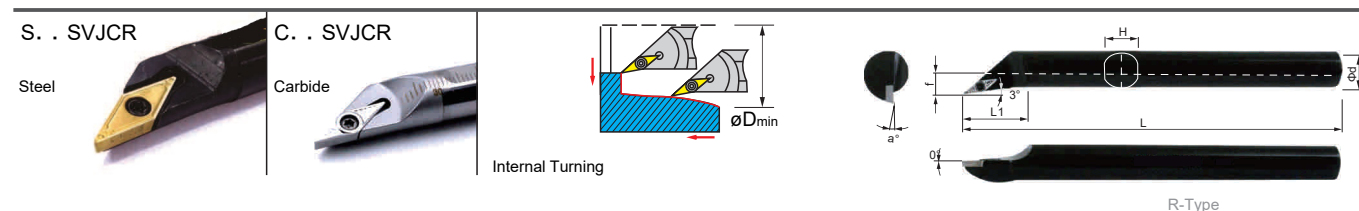

Ordering code	Dimensions							Insert	Screw	Wrench	Stock	
	δD_{min}	δd	f	L	L1	H	α°				R	L
S08H-SVJCR/L08	10	8	5	100	20	7	15°	VC..0802..	230066	230052	•	•
S10K-SVJCR/L08	12	10	6	125	25	9	15°				•	•
S10K-SVJCR/L11	12	10	6	125	25	9	12°				•	•
S12M-SVJCR/L11	14	12	7	150	30	11	12°	VC..1103..	230075	230054	•	•
S16Q-SVJCR/L11	22	16	11.5	180	40	15	10°				•	•
S20R-SVJCR/L11	27	20	13.5	200	45	19	8°				•	•
S20R-SVJCR/L16	27	20	13.5	200	50	19	10°	VC..1604..	230092	230057	•	•
S25S-SVJCR/L16	32	25	16	250	50	24	8°				•	•
S32T-SVJCR/L16	40	32	19.5	300	60	30	10°				•	•
S40T-SVJCR/L16	50	40	23.5	300	65	38	8°	•	•			

Carbide Steel Shock-Proof Toolholder(Shock-Proof Effect > 8 Times Toolholder Diameter)

C06J-SVJCR/L08	8.5	6	3.25	110	15	5	15°	VC..0802..	230066	230052	•	•
C08K-SVJCR/L08	10	8	5	125	15	7	15°				•	•
C10M-SVJCR/L08	12	10	6	150	20	9	15°				•	•
C10M-SVJCR/L11	12	10	6	150	20	9	12°	VC..1103..	230075	230054	•	•
C12M-SVJCR/L11	14	12	7	150	20	11	12°				•	•
C12Q-SVJCR/L11	14	12	7	180	20	11	12°				•	•
C16R-SVJCR/L11	18	16	9	200	25	15	10°	VC..1604..	230092	230057	•	•
C20R-SVJCR/L11	22	20	11	200	30	19	8°				•	•
C20S-SVJCR/L11	22	20	11	250	30	19	10°				•	•
C25S-SVJCR/L16	28	25	14	200	35	24	8°	•	•			

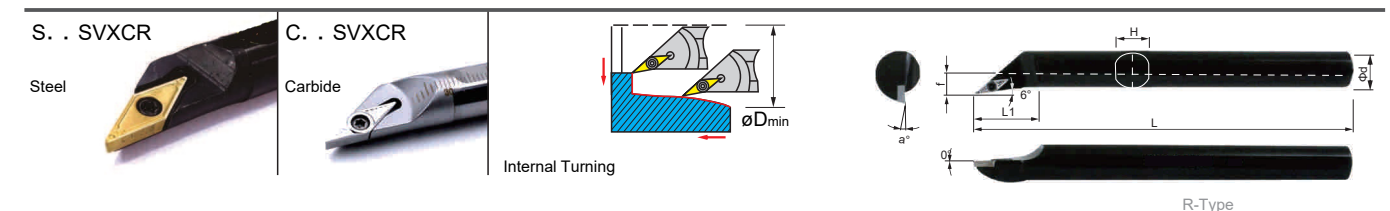

Ordering code	Dimensions							Insert	Screw	Wrench	Stock	
	δD_{min}	δd	f	L	L1	H	α°				R	L
S08H-SVXCR/L08	10	8	5	100	20	7	15°	VC..0802..	230066	230052	•	•
S10K-SVXCR/L08	12	10	6	125	25	9	15°				•	•
S10K-SVXCR/L11	12	10	6	125	25	9	12°				•	•
S12M-SVXCR/L11	14	12	7	150	30	11	12°	VC..1103..	230075	230054	•	•
S16Q-SVXCR/L11	22	16	11.5	180	40	15	10°				•	•
S20R-SVXCR/L11	27	20	13.5	200	45	19	8°				•	•
S20R-SVXCR/L16	27	20	13.5	200	50	19	10°	VC..1604..	230092	230057	•	•
S25S-SVXCR/L16	32	25	16	250	50	24	8°				•	•
S32T-SVXCR/L16	40	32	19.5	300	60	30	10°				•	•
S40T-SVXCR/L16	50	40	23.5	300	65	38	8°	•	•			

Carbide Steel Shock-Proof Toolholder(Shock-Proof Effect > 8 Times Toolholder Diameter)

C06J-SVXCR/L08	8.5	6	3.25	110	15	5	15°	VC..0802..	230066	230052	•	•
C08K-SVXCR/L08	10	8	5	125	15	7	15°				•	•
C10M-SVXCR/L08	12	10	6	150	20	9	15°				•	•
C10M-SVXCR/L11	12	10	6	150	20	9	12°	VC..1103..	230075	230054	•	•
C12M-SVXCR/L11	14	12	7	150	20	11	12°				•	•
C12Q-SVXCR/L11	14	12	7	180	20	11	12°				•	•
C16R-SVXCR/L11	18	16	9	200	25	15	10°	VC..1604..	230092	230057	•	•
C20R-SVXCR/L11	22	20	11	200	30	19	8°				•	•
C20S-SVXCR/L11	22	20	11	250	30	19	10°				•	•
C25S-SVXCR/L16	28	25	14	200	35	24	8°	•	•			

S Type Internal Turning Tool

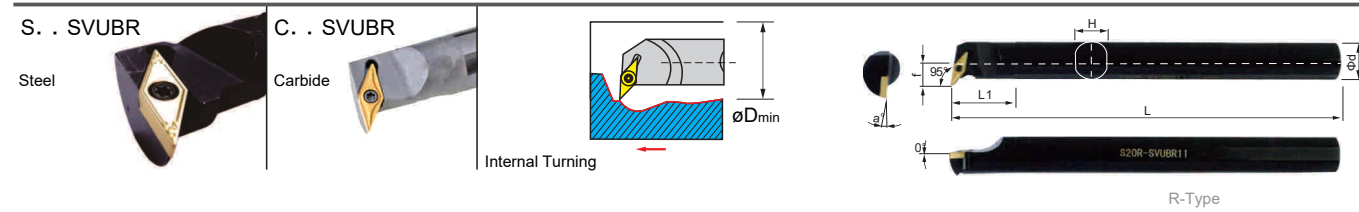

Ordering code	Dimensions							Insert	Screw	Wrench	Stock	
	ϕD_{min}	ϕd	f	L	L1	H	α°				R	L
S16Q-SVUBR/L11	22	16	12.5	180	30	15	10°	VB..1103..	230075	230054	•	•
S20R-SVUBR/L11	27	20	14	200	32	19	8°				•	•
S20R-SVUBR/L16	31	20	20	200	50	19	10°	VB..1604..	230092	230057	•	•
S25S-SVUBR/L16	35	25	20	250	50	24	8°				•	•
S32T-SVUBR/L16	42	32	22.5	300	50	30	6°				•	•
S40T-SVUBR/L16	51	40	27	300	55	38	6°				•	•
Carbide Steel Shock-Proof Toolholder(Shock-Proof Effect > 8 Times Toolholder Diameter2)												
C16R-SVUBR/L11	22	16	13	200	25	15	10°	VB..1103..	230075	230054	•	•
C20R-SVUBR/L11	27	20	15	200	30	19	8°				•	•
C20S-SVUBR/L11	27	20	15	250	30	19	8°				•	•
C20R-SVUBR/L16	31	20	19	200	30	19	10°	VB..1604..	230092	230057	•	•
C20S-SVUBR/L16	31	20	19	250	30	19	8°				•	•
C25R-SVUBR/L16	35	25	20	200	35	24	8°				•	•
C25S-SVUBR/L16	35	25	20	250	35	24	8°				•	•

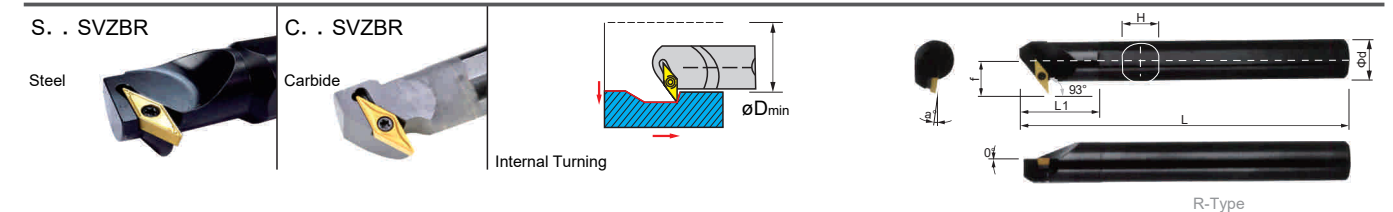

Ordering code	Dimensions							Insert	Screw	Wrench	Stock	
	ϕD_{min}	ϕd	f	L	L1	H	α°				R	L
S16Q-SVZBR/L11	22	16	11.5	180	34	15	10°	VB..1103..	230075	230054	•	•
S20R-SVZBR/L11	27	20	14	200	38	19	8°				•	•
S25S-SVZBR/L16	34	25	19.5	250	50	20	8°	VB..1604..	230092	230057	•	•
S32T-SVZBR/L16	42	32	23.5	300	50	30	10°				•	•
S40T-SVZBR/L16	50	40	27	300	60	38	8°				•	•
Carbide Steel Shock-Proof Toolholder(Shock-Proof Effect > 8 Times Toolholder Diameter)												
C16R-SVZBR/L11	22	16	11.5	200	25	15	10°	VB..1103..	230075	230054	•	•
C20R-SVZBR/L11	27	20	14	200	30	19	8°				•	•
C20S-SVZBR/L11	27	20	14	250	30	19	8°				•	•
C20R-SVZBR/L16	27	20	14	200	30	19	10°	VB..1604..	230092	230057	•	•
C20S-SVZBR/L16	27	20	14	250	30	19	10°				•	•
C25R-SVZBR/L16	34	25	19.5	200	35	24	8°				•	•
C25S-SVZBR/L16	34	25	19.5	250	35	24	8°				•	•

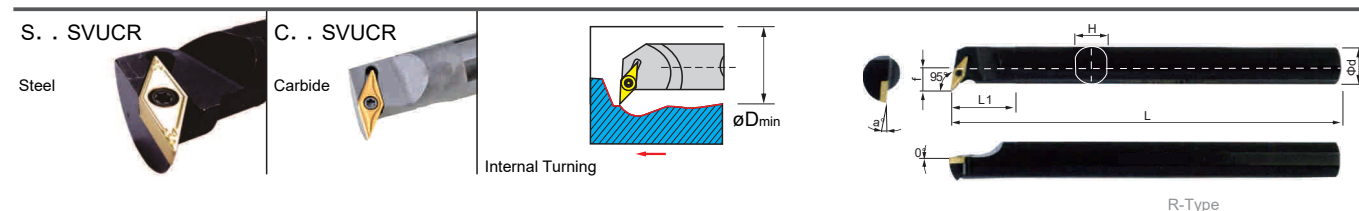

Ordering code	尺寸 Dimensions							Insert	Screw	Wrench	Stock	
	ϕD_{min}	ϕd	f	L	L1	H	α°				R	L
S16Q-SVUCR/L11	22	16	12.5	180	30	15	10°	VC..1103..	230075	230054	•	•
S20R-SVUCR/L11	27	20	14	200	32	19	8°				•	•
S20R-SVUCR/L16	31	20	20	200	50	19	10°	VC..1604..	230092	230057	•	•
S25S-SVUCR/L16	35	25	20	250	50	24	8°				•	•
S32T-SVUCR/L16	42	32	22.5	300	50	30	6°				•	•
S40T-SVUCR/L16	51	40	27	300	55	38	6°				•	•
Carbide Steel Shock-Proof Toolholder(Shock-Proof Effect > 8 Times Toolholder Diameter)												
C16R-SVUCR/L11	22	16	13	200	25	15	10°	VC..1103..	230075	230054	•	•
C20R-SVUCR/L11	27	20	15	200	30	19	8°				•	•
C20S-SVUCR/L11	27	20	15	250	30	19	8°				•	•
C20R-SVUCR/L16	31	20	19	200	30	19	10°	VC..1604..	230092	230057	•	•
C20S-SVUCR/L16	31	20	19	250	30	19	8°				•	•
C25R-SVUCR/L16	35	25	20	200	35	24	8°				•	•
C25S-SVUCR/L16	35	25	20	250	35	24	8°				•	•

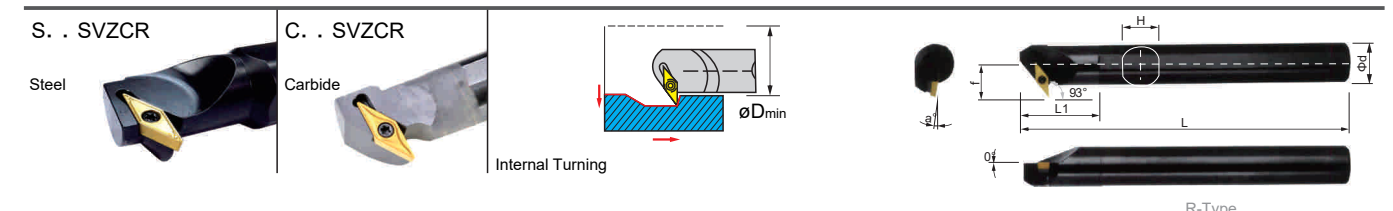

Ordering code	Dimensions							Insert	Screw	Wrench	Stock	
	ϕD_{min}	ϕd	f	L	L1	H	α°				R	L
S16Q-SVZCR/L11	22	16	11.5	180	34	15	10°	VC..1103..	230075	230054	•	•
S20R-SVZCR/L11	27	20	14	200	38	19	8°				•	•
S25S-SVZCR/L16	34	25	19.5	250	50	20	8°	VC..1604..	230092	230057	•	•
S32T-SVZCR/L16	42	32	23.5	300	50	30	10°				•	•
S40T-SVZCR/L16	50	40	27	300	60	38	8°				•	•
Carbide Steel Shock-Proof Toolholder(Shock-Proof Effect > 8 Times Toolholder Diameter)												
C16R-SVZCR/L11	22	16	11.5	200	25	15	10°	VC..1103..	230075	230054	•	•
C20R-SVZCR/L11	27	20	14	200	30	19	8°				•	•
C20S-SVZCR/L11	27	20	14	250	30	19	8°				•	•
C20R-SVZCR/L16	27	20	14	200	30	19	10°	VC..1604..	230092	230057	•	•
C20S-SVZCR/L16	27	20	14	250	30	19	10°				•	•
C25R-SVZCR/L16	34	25	19.5	200	35	24	8°				•	•
C25S-SVZCR/L16	34	25	19.5	250	35	24	8°				•	•

S Type Internal Turning Tool

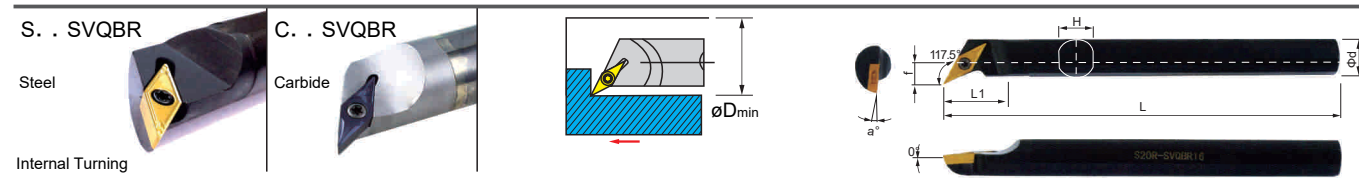

Ordering code	Dimensions							Insert	Screw	Wrench	Stock	
	ϕD_{min}	ϕd	f	L	L1	H	α°				R	L
S16Q-SVQBR/L11	22	16	11.5	180	35	15	10°	VB..1103..	230075	230054	•	•
S20R-SVQBR/L11	27	20	14	200	39	19	8°				•	•
S20R-SVQBR/L16	27	20	14	200	50	19	10°				•	•
S25S-SVQBR/L16	32	25	16.5	250	50	24	8°				•	•
S32T-SVQBR/L16	41	32	22.5	300	55	30	10°				•	•
S40T-SVQBR/L16	50	40	27	300	55	38	8°	•	•			
Carbide Steel Shock-Proof Toolholder(Shock-Proof Effect > 8 Times Toolholder Diameter)												
C16R-SVQBR/L11	22	16	11.5	200	25	15	10°	VB..1103..	230075	230054	•	•
C20R-SVQBR/L11	27	20	14	200	30	19	8°				•	•

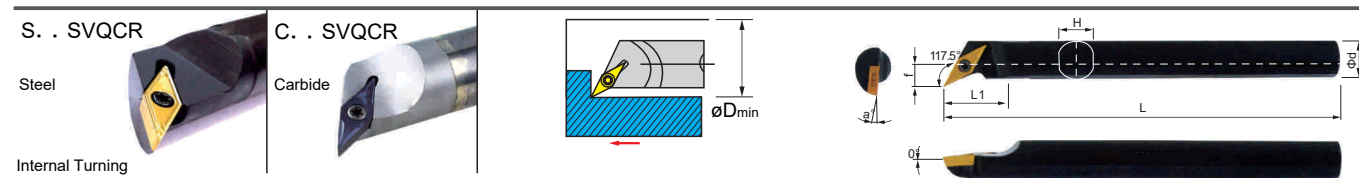

Ordering code	Dimensions							Insert	Screw	Wrench	Stock	
	ϕD_{min}	ϕd	f	L	L1	H	α°				R	L
S16Q-SVQCR/L11	22	16	11.5	180	35	15	10°	VC..1103..	230075	230054	•	•
S20R-SVQCR/L11	27	20	14	200	39	19	8°				•	•
S20R-SVQCR/L16	27	20	14	200	50	19	10°				•	•
S25S-SVQCR/L16	32	25	16.5	250	50	24	8°				•	•
S32T-SVQCR/L16	41	32	22.5	300	55	30	10°				•	•
S40T-SVQCR/L16	50	40	27	300	55	38	8°	•	•			
Carbide Steel Shock-Proof Toolholder(Shock-Proof Effect > 8 Times Toolholder Diameter)												
C16R-SVQCR/L11	22	16	11.5	200	25	15	10°	VC..1103..	230075	230054	•	•
C20R-SVQCR/L11	27	20	14	200	30	19	8°				•	•

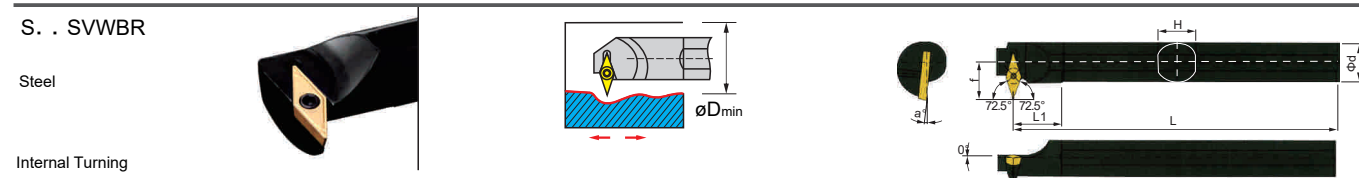

Ordering code	Dimensions							Insert	Screw	Wrench	Stock	
	ϕD_{min}	ϕd	f	L	L1	H	α°				R	L
S25S-SVWBR/L16	38	25	23	250	33	24	6°	VB..1604..	230092	230057	•	•
S32T-SVWBR/L16	45	32	26	300	41	30	6°				•	•

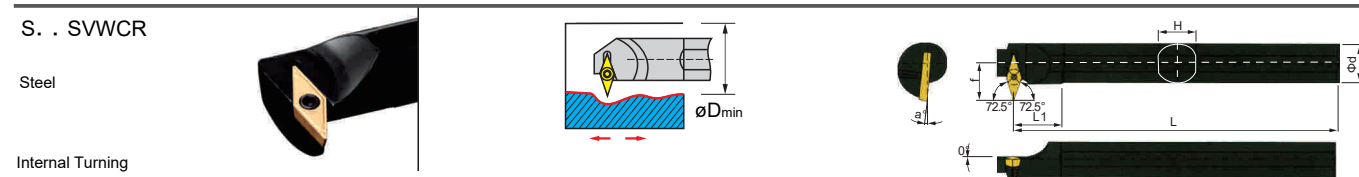

Ordering code	Dimensions							Insert	Screw	Wrench	Stock	
	ϕD_{min}	ϕd	f	L	L1	H	α°				R	L
S25S-SVWCR/L16	38	25	23	250	33	24	6°	VC..1604..	230092	230057	•	•
S32T-SVWCR/L16	45	32	26	300	41	30	6°				•	•

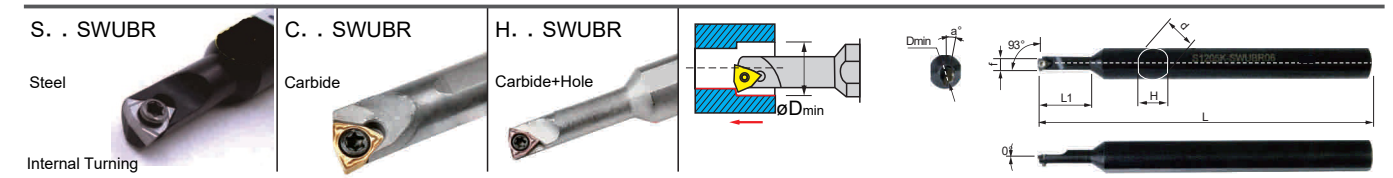

Ordering code	Dimensions							Insert	Screw	Wrench	Stock				
	ϕD_{min}	ϕd	f	L	L1	H	α°				R	L			
S06H-SWUBR/L06	7	6	3.5	100	16	5.4	15°	WB..0601..	230066	230052	•	•			
S0705H-SWUBR/L06	6	7	3	100	16	6	15°				•	•			
S0805H-SWUBR/L06	6	8	3	100	16	7	15°				•	•			
S1005K-SWUBR/L06	6	10	3	125	16	9	15°				•	•			
S1205K-SWUBR/L06	6	12	3	125	20	11	15°				•	•			
S1605H-SWUBR/L06	6	16	3	125	20	15	15°				•	•			
S0806J-SWUBR/L06	7	8	3.5	110	20	7	15°				•	•			
S1006K-SWUBR/L06	7	10	3.5	125	20	9	12°				•	•			
S1207K-SWUBR/L06	8	12	4	125	25	11	12°				•	•			
S1607M-SWUBR/L06	8	16	4	150	25	15	12°				•	•			
Carbide Steel Shock-Proof Toolholder(Shock-Proof Effect > 8 Times Toolholder Diameter)															
C04G-SWUBR/L06	5	4	2.6	90	15	3.6	15°				WB..0601..	230066	230052	•	•
C05H-SWUBR/L06	6	5	3	100	15	4.5	15°							•	•
C06J-SWUBR/L06	7	6	3.5	110	15	5.5	12°							•	•
C07K-SWUBR/L06	8	7	4	125	15	6	12°							•	•
C0807K-SWUBR/L06	8	8	4	125	15	7	12°	•	•						
High-Speed Steel Shock-Proof Toolholder (Shock-Proof Effect > 5 Times Toolholder Diameter)															
H06J-SWUBR/L06	7	6	3.4	110	12	5.4	15°	WB..0601..	230066	230052	•	•			
H1005K-SWUBR/L06	6	10	3	125	22	9	15°				•	•			
H1205K-SWUBR/L06	6	12	3	125	22	11	15°				•	•			

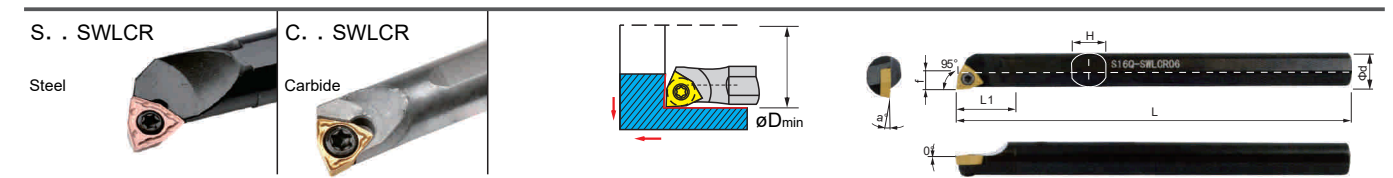

Ordering code	Dimensions							Insert	Screw	Wrench	Stock				
	ϕD_{min}	ϕd	f	L	L1	H	α°				R	L			
S08K-SWLCR/L03	10	8	5	125	25	7	13°	WC..0302..	230074	230054	•	•			
S10K-SWLCR/L03	12	10	6	125	25	9	10°				•	•			
S08K-SWLCR/L04	10	8	5	125	25	7	13°				•	•			
S10K-SWLCR/L04	13	10	6.5	125	30	9	10°				•	•			
S12M-SWLCR/L04	16	12	7.5	150	37	11	13°				•	•			
S12M-SWLCR/L05	15	12	7	150	37	11	12°				•	•			
S14N-SWLCR/L05	17	14	8.5	160	40	13	10°				•	•			
S16Q-SWLCR/L06	20	16	9.5	180	40	15	10°				•	•			
S20R-SWLCR/L06	25	20	11.5	200	40	19	8°				•	•			
S25S-SWLCR/L06	31	25	14	250	40	24	6°				•	•			
Carbide Steel Shock-Proof Toolholder(Shock-Proof Effect > 8 Times Toolholder Diameter)															
C08K-SWLCR/L03	10	8	5	125	15	7	13°				WC..0302..	230074	230054	•	•
C10K-SWLCR/L03	12	10	6	125	20	9	10°							•	•
C08K-SWLCR/L04	10	8	5	125	15	7	13°							•	•
C10K-SWLCR/L04	13	10	6.5	125	20	9	10°							•	•
C12M-SWLCR/L04	16	12	7.5	150	20	11	13°	•	•						
C12M-SWLCR/L05	15	12	7	150	20	11	12°	•	•						
C14N-SWLCR/L05	17	14	8.5	160	25	13	10°	•	•						
C16Q-SWLCR/L06	20	16	9.5	180	25	15	10°	•	•						
C20R-SWLCR/L06	25	20	11.5	200	30	19	8°	•	•						
C25S-SWLCR/L06	31	25	14	250	35	24	6°	•	•						

Thread turning tool system

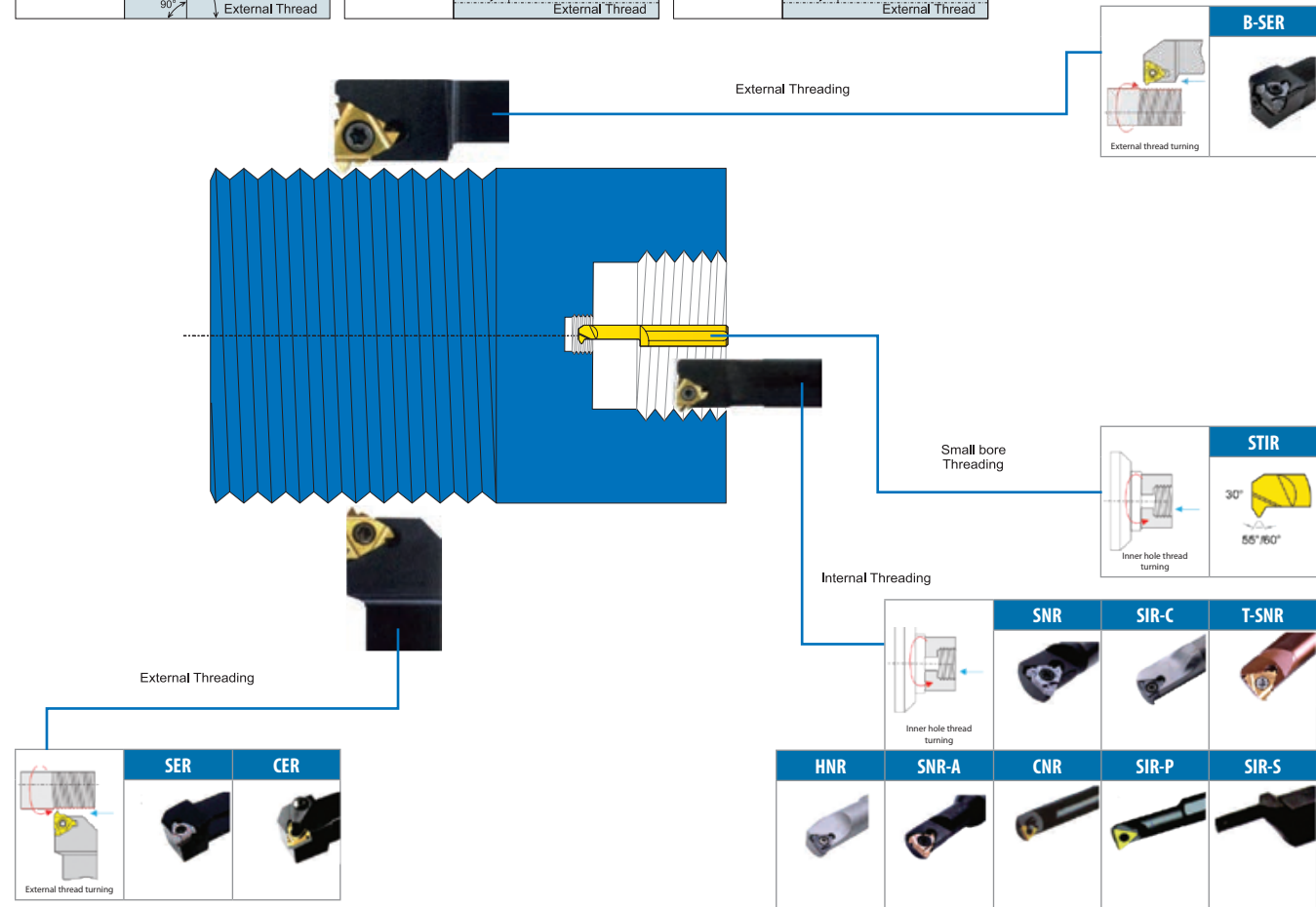

Thread turning tool system

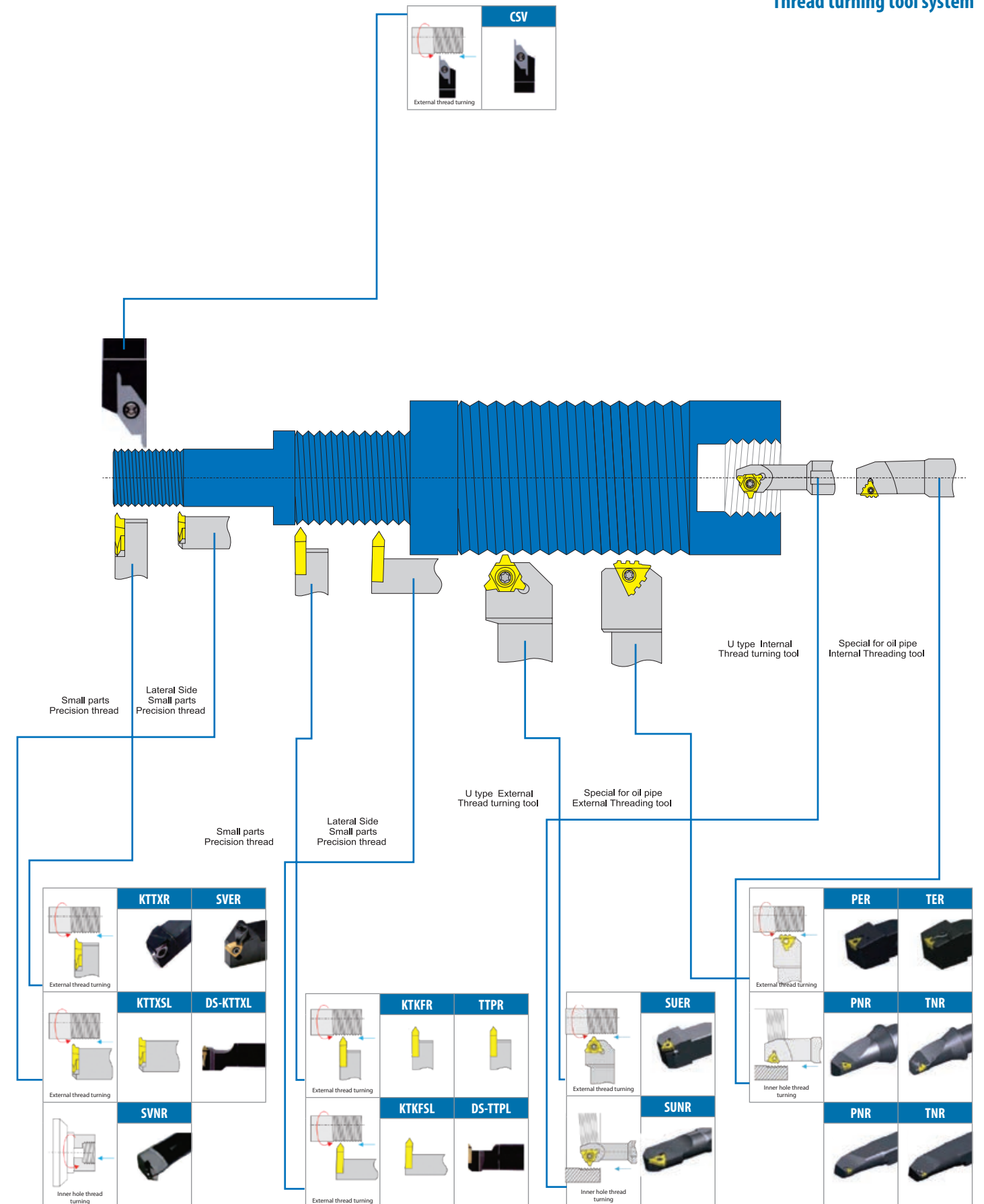

External / internal thread turning tool

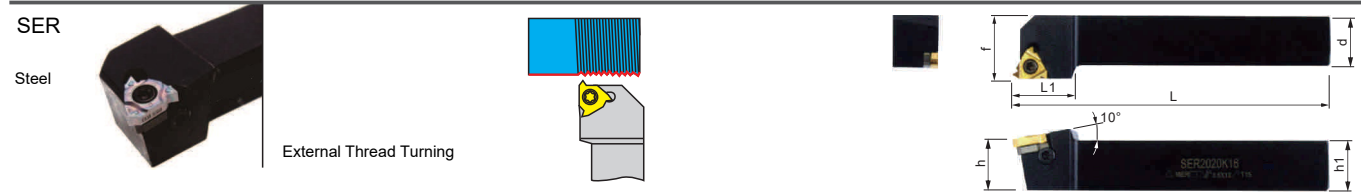

Ordering code	Dimensions						Insert	Shim	Screw	Screw	Wrench	Stock	
	h	b	L	L1	h1	f						R	L
SER/L1010H11	10	10	100	16	10	12	11ER/L..		230074		230054	•	•
SER/L1212H11	12	12	100	16	12	16						•	•
SER/L1616H11	16	16	100	20	16	20						•	•
SER/L1212H16	12	12	100	20	12	18	16ER/L..	230032 230033	230087	230079	230057	•	•
SER/L1616H16	16	16	100	20	16	20						•	•
SER/L2020K16	20	20	125	22	20	25						•	•
SER/L2525M16	25	25	150	22	25	32	22ER/L..	230034 230035	230098	230079	230058 230057	•	•
SER/L3225P16	32	32	170	25	32	32						•	•
SER/L2020K22	20	20	125	26	20	32						•	•
SER/L2525M22	25	25	150	26	25	32						•	•
SER/L3225P22	32	32	170	28	32	32						•	•

R-Type

UER

DIN103

Application

Specification	Depth	Pitch	Dimension (mm)						PCD1	CBN1	CBN2	PM30	PMK25	PMK26	PMK27	PMK30	PMK31
			Hmin	φd	L	A	S	F									
22UER 6.0 TR 7.0 TR	3.50 4.00	6.0 7.0	5.1	22	12.7	2.0	11.0					•	•	•	•	•	•
27UER 8.0 TR 9.0 TR 10.0 TR	4.57 9.0 10.0	8.0 6.35 6.35	27	15.87	2.6	13.7						•	•	•	•	•	•

SUER

Application

Ordering code	Dimensions					Insert	Screw	Wrench	Shim	Screw	Wrench	Stock	
	h	b	L	h1	f							R	L
SUER/L 3232P22	32	32	170	32	37	22UE..	230124	230057	230036	230076	230047	•	•
4040R22	40	40	200	40	45							•	•
3232P27	32	32	170	32	37							•	•
4040R27	40	40	200	40	45	27UE..	230105	230058	230037	230076	230047	•	•
5050S27	50	50	250	50	55							•	•

UNR

SAGE

Application

Specification	Depth	Pitch	Dimension (mm)						PCD1	CBN1	CBN2	PM30	PMK25	PMK26	PMK27	PMK30	PMK31
			Hmin	φd	L	A	S	F									
22UIR 6.0 TR 7.0 TR	3.50 4.00	6.0 7.0	5.1	22	12.7	2.0	11.0					•	•	•	•	•	•
27UIR 8.0 TR 9.0 TR 10.0 TR	4.57 9.0 10.0	8.0 6.35 6.35	27	15.87	2.6	13.7						•	•	•	•	•	•

SUNR

Application

Ordering code	Dimensions					Insert	Screw	Wrench	Shim	Screw	Wrench	Stock	
	Dmin	Ød	L	L1	f							R	L
SUNR/L 0032S22	32	32	250	60	25.5	22UE..	230124	230057	230036	230076	230047	•	•
0040T22	40	40	300	60	29.5							•	•
0032S27	32	32	250	60	24.7							•	•
0040T27	40	40	300	60	29.4	27UE..	230105	230058	230037	230076	230047	•	•
0050U27	50	50	350	75	34.3							•	•
0060V27	60	60	400	75	39.3							•	•

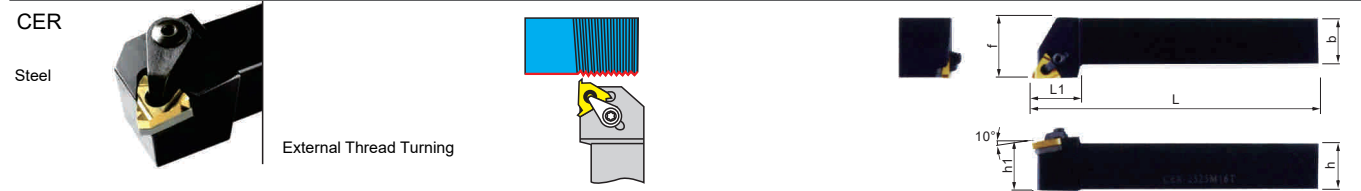

Ordering code	Dimensions						Insert	Shim	Screw	Clamp	Screw	Wrench	Stock	
	h	b	L	L1	h1	f							R	L
CER/L1616H16	16	16	100	20	16	20	16ER/L..	230032 230033	230087	230128	230114	230057 230047	•	•
CER/L2020K16	20	20	125	22	20	25							•	•
CER/L2525M16	25	25	150	22	25	32							•	•
CER/L3225P16	32	32	170	25	32	32	22ER/L..	230034 230035	230100	230128	230114	230057 230047	•	•
CER/L2525M22	25	25	150	26	25	32							•	•
CER/L3225P22	32	32	170	28	32	32							•	•

R-Type

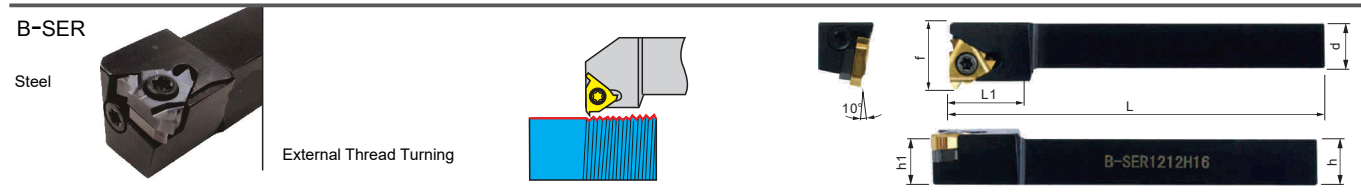

Ordering code	Dimensions						Insert	Shim	Screw	Screw	Wrench	Stock	
	h	b	L	L1	h1	f						R	L
B-SER/L1010H16	10	10	100	20	10	18	16ER/L..	230032 230033	230087	230079	230057	•	•
B-SER/L1212H16	12	12	100	20	12	18						•	•
B-SER/L1616H16	16	16	100	20	16	20						•	•
B-SER/L2020K16	20	20	125	22	20	25	22ER/L..	230034 230035	230098	230079	230058 230057	•	•
B-SER/L2525M16	25	25	150	22	25	32						•	•

R-Type

Material	Cutting Environment	Stable Cutting	General Cutting	Unstable Cutting	PCD1	CBN1	CBN2	PM30	PMK25	PMK26	PMK27	PMK30	PMK31
					•	•	•	•	•	•	•	•	•
P Steel	•	•	•	•	•	•	•	•	•	•	•	•	•
M Stainless Steel	•	•	•	•	•	•	•	•	•	•	•	•	•
K Iron	•	•	•	•	•	•	•	•	•	•	•	•	•
N Aluminum/Copper/Magnesium/Zinc/Plastic/Wood	•	•	•	•	•	•	•	•	•	•	•	•	•
S Carbide/Powder Metallurgy	•	•	•	•	•	•	•	•	•	•	•	•	•
H Titanium/Superalloy/Carbon Fiber	•	•	•	•	•	•	•	•	•	•	•	•	•

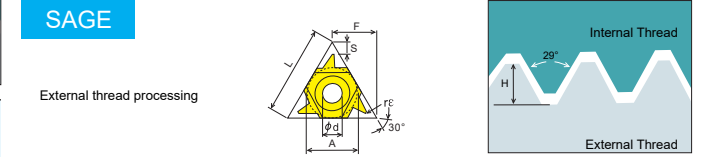

Specification	Depth	Pitch	Dimension (mm)						PCD1	CBN1	CBN2	PM30	PMK25	PMK26	PMK27	PMK30	PMK31
			Hmin	φd	L	A	S	F									
22UER 5.0 SAGE 6.0 SAGE	5.0 6.0	5.1	22	0.62 0.75	12.7	11.0						•	•	•	•	•	•

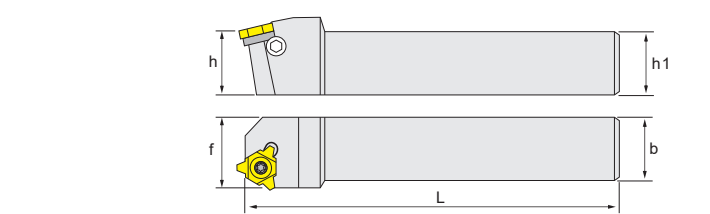

Ordering code	Dimensions					Insert	Screw	Wrench	Shim	Screw	Wrench	Stock	
	h	b	L	h1	f							R	L
SUER/L 3232P22	32	32	170	32	37	22UE..	230124	230057	230036	230076	230047	•	•
4040R22	40	40	200	40	45							•	•
3232P27	32	32	170	32	37							•	•
4040R27	40	40	200	40	45	27UE..	230105	230058	230037	230076	230047	•	•
5050S27	50	50	250	50	55							•	•

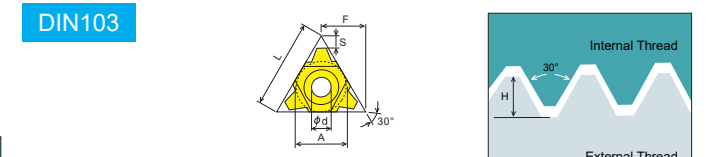

Specification	Depth	Pitch	Dimension (mm)						PCD1	CBN1	CBN2	PM30	PMK25	PMK26	PMK27	PMK30	PMK31
			Hmin	φd	L	A	S	F									
22UIR 6.0 TR 7.0 TR	3.50 4.00	6.0 7.0	5.1	22	12.7	2.0	11.0					•	•	•	•	•	•
27UIR 8.0 TR 9.0 TR 10.0 TR	4.57 9.0 10.0	8.0 6.35 6.35	27	15.87	2.6	13.7						•	•	•	•	•	•

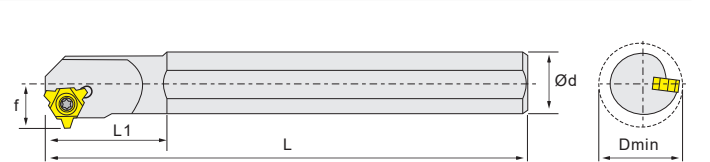

Ordering code	Dimensions					Insert	Screw	Wrench	Shim	Screw	Wrench	Stock	
	Dmin	Ød	L	L1	f							R	L
SUNR/L 0032S22	32	32	250	60	25.5	22UE..	230124	230057	230036	230076	230047	•	•
0040T22	40	40	300	60	29.5							•	•
0032S27	32	32	250	60	24.7							•	•
0040T27	40	40	300	60	29.4	27UE..	230105	230058	230037	230076	230047	•	•
0050U27	50	50	350	75	34.3							•	•
0060V27	60	60	400	75	39.3							•	•

TTX

Thread Application: General Industry

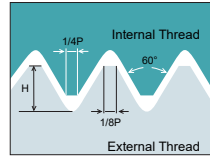

Material	Cutting Environment		General Cutting		Unstable Cutting		Material											
	Stable Cutting	General Cutting(Second recommend)	General Cutting	Unstable Cutting	PCD1	CBN1	CBN2	PM30	NO21	PMK25	PMK26	PMK27	PMK30	PMK31	PMK35	PMK37	PMK38	
P Steel	●	○	●	○	●	○	○	○	○	○	○	○	○	○	○	○	○	○
M Stainless Steel	○	○	○	○	○	○	○	○	○	○	○	○	○	○	○	○	○	○
K Iron	○	○	○	○	○	○	○	○	○	○	○	○	○	○	○	○	○	○
N Aluminum/Copper/Magnesium/Zinc/Plastic/Wood	○	○	○	○	○	○	○	○	○	○	○	○	○	○	○	○	○	○
S Carbide/Powder Metallurgy	○	○	○	○	○	○	○	○	○	○	○	○	○	○	○	○	○	○
H Titanium/Superalloy/Carbon Fiber	○	○	○	○	○	○	○	○	○	○	○	○	○	○	○	○	○	○

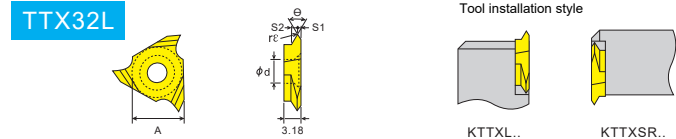
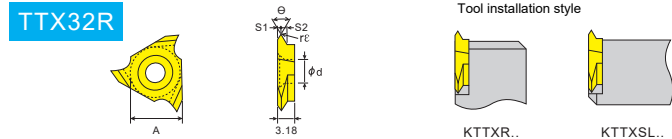

Application	Specification	Pitch of Screw		Dimension (mm)						Material														
		(mm)	(tpi)	rE	S1	S2	A	phi d	PCD1	CBN1	CBN2	PM30	NO21	PMK25	PMK26	PMK27	PMK30	PMK31	PMK35	PMK37	PMK38			
Thread (external thread)	TTX32R 6000	0.5-1.0	56-32	0.00	0.6	1.12																		
	6000S	0.5-1.0	56-32	0.00	0.3	1.12																		
	60005S	0.5-1.0	48-32	0.05	0.6	1.12																		
	6001	0.5-1.0	48-32	0.05	0.3	1.12	9.525	4.4																
	6002	1.0-2.0	28-14	0.1	1.1	1.62																		
	6003	1.5-2.5	16-10	0.2	1.1	1.62																		
Thread (internal thread)	TTX32R 5501	-	28-10	0.1	1.1	0.5	9.525	4.4																
	5502	-	14-10	0.2	1.1	0.5																		

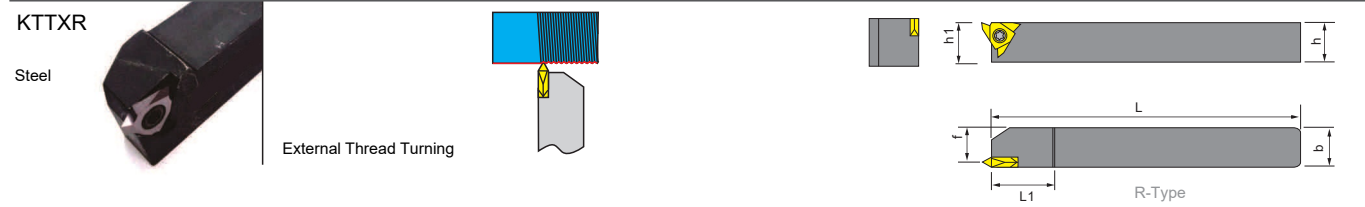

Ordering code	Dimensions						Insert	Screw	Wrench	Stock		
	h	b	L	L1	h1	f				R	L	
KTTXR/L1010F32	10	10	90	20	10	12	TTX32..	230092	230059	230057	●	●
KTTXR/L1212H32	12	12	100	20	12	16					●	●
KTTXR/L1616H32	16	16	100	20	16	20					●	●
KTTXR/L2020K32	20	20	125	22	20	25	TT43..	230101			●	●
KTTXR/L2020K43	20	20	125	28	20	25					●	●
KTTXR/L2525M43	25	25	150	30	25	32					●	●
KTTXR/L3232P43	32	32	170	30	32	40					●	●

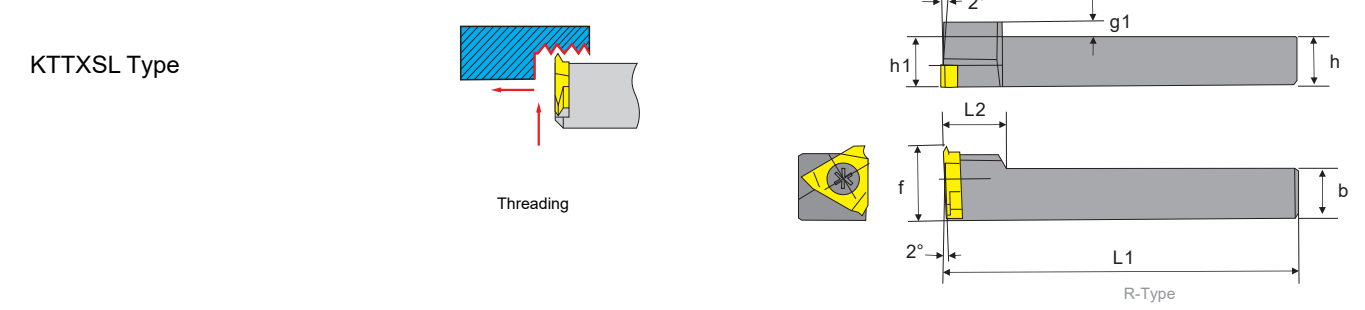

Ordering code	Dimensions						Insert	Wrench	Screw	Stock	
	g1	h=h1	b	L1	L2	f				R	L
KTTXSR/L 1010H16	2	10	10	100	12	16	TTX32..	230057	230092	○	●
1212H16	0	12	12	100	16	20				○	●
1616H16	0	16	16	100	20	24				○	●
2020K16	0	20	20	125	25	30				○	●
2525M16	0	25	25	150	32	35				○	○

External / internal thread turning tool

TKFT

Thread Application: General Industry

Material	Cutting Environment		General Cutting		Unstable Cutting		Material											
	Stable Cutting	General Cutting(Second recommend)	General Cutting	Unstable Cutting	PCD1	CBN1	CBN2	PM30	NO21	PMK25	PMK26	PMK27	PMK30	PMK31	PMK35	PMK37	PMK38	
P Steel	●	○	●	○	●	○	○	○	○	○	○	○	○	○	○	○	○	○
M Stainless Steel	○	○	○	○	○	○	○	○	○	○	○	○	○	○	○	○	○	○
K Iron	○	○	○	○	○	○	○	○	○	○	○	○	○	○	○	○	○	○
N Aluminum/Copper/Magnesium/Zinc/Plastic/Wood	○	○	○	○	○	○	○	○	○	○	○	○	○	○	○	○	○	○
S Carbide/Powder Metallurgy	○	○	○	○	○	○	○	○	○	○	○	○	○	○	○	○	○	○
H Titanium/Superalloy/Carbon Fiber	○	○	○	○	○	○	○	○	○	○	○	○	○	○	○	○	○	○

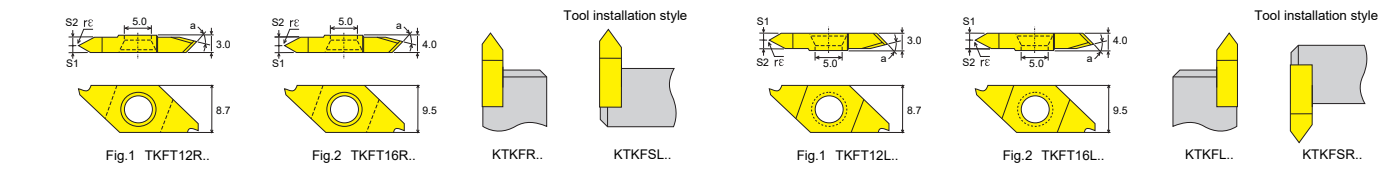

Application	Specification	Pitch of Screw		Dimension (mm)						Material														
		(mm)	(tpi)	rE	S1	S2	a	Fig	PCD1	CBN1	CBN2	PM30	NO21	PMK25	PMK26	PMK27	PMK30	PMK31	PMK35	PMK37	PMK38			
Thread (external thread)	TKFT12R A6000 B6000 A60005 B60005 N6001	0.2-0.6	64-48	<0.05	0.4	2.1			1															
		0.2-0.6	64-48	<0.05	2.1	0.4																		
		0.5-1.25	48-24	0.05	0.8	1.7	60°																	
		0.5-1.25	48-24	0.05	1.7	0.8																		
		1.0-1.50	24-18	0.1	1.25	1.25																		
Thread (external thread)	TKFT16R A6000 B6000 A60005 B60005 N6001	0.2-0.6	64-48	<0.05	0.4	2.1			0															
		0.2-0.6	64-48	<0.05	2.1	0.4																		
		0.5-1.25	48-24	0.05	0.8	1.7	60°																	
		0.5-1.25	48-24	0.05	1.7	0.8																		
		1.0-1.50	24-18	0.1	1.25	1.25																		
Thread (external thread)	TKFT12R A55005 B55005	-	40-16	0.05	0.8	1.7			55°															
		-	40-16	0.05	1.7	0.8																		
Thread (external thread)	TKFT16R A55005 B55005	-	40-16	0.05	0.8	1.7			55°															
		-	40-16	0.05	1.7	0.8																		

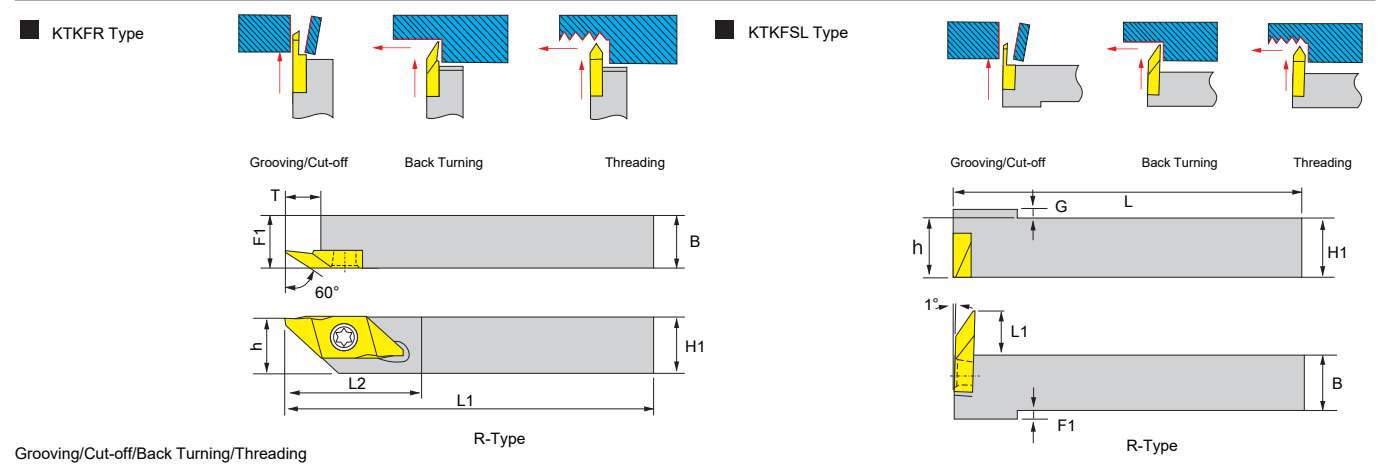

Ordering code	Dimensions							Insert	Wrench	Screw	Stock	
	H1=h	B	L1	L2	T	F1	R				L	
KTKFR/L	0808K-12	8	8	125	15	6	8	TKF..12R.. TKFB..12R.. TKFT..12R..	230058	230096	●	●
	1010K-12	10	10	125	15	6	10				●	●
	1212F-12	12	12	85	-	6	12				●	●
	1212M-12	12	12	150	-	6	12				●	●
KTKFR/L	1616M-12	16	16	150	-	6	16	TKF..12R.. TKFB..12R.. TKFT..12R..	230058	230096	●	●
	0808K-16	8	8	125	15	8	8				●	●
	1010K-16	10	10	125	20	8	10				●	●
	1212F-16	12	12	85	-	8	12				●	●
KTKFR/L	1212M-16	12	12	150	-	8	12	TKF..12R.. TKFB..12R.. TKFT..12R..	230058	230096	●	●
	1616M-16	16	16	150	-	8	16				●	●
	1010JX12	10	10	120	6.0	2	6				●	●
	1212JX12	12	12	120	6.0	0	4				●	●
KTKFSL/L	1616JX12	16	16	120	6.0	0	2	TKF..12R.. TKFB..12R.. TKFT..12R..	230058	230096	●	●
	2020JX12	20	20	120	6.0	0	0				●	●
	1010JX16	10	10	120	8.0	2	8				●	●
	1212JX16	12	12	120	8.0	0	6				●	●
KTKFSL/L	1616JX16	16	16	120	8.0	0	4	TKF..12R.. TKFB..12R.. TKFT..12R..	230058	230096	●	●
	2020JX16	20	20	120	8.0	0	2				●	●

External / internal thread turning tool

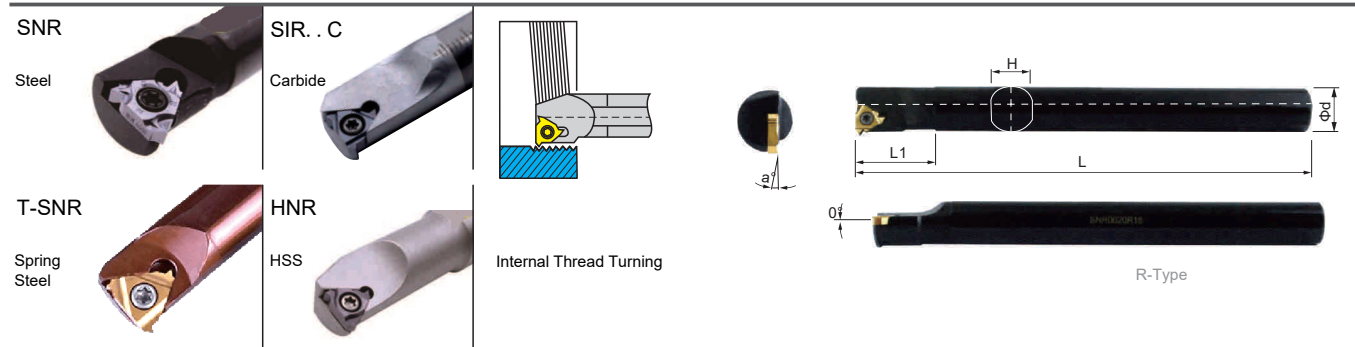

Ordering code	Dimensions							Insert	Shim	Screw	Wrench	Screw	Stock	
	øD _{min}	ød	f	L	L1	H	α°						R	L
SNR/L0007J08	9	7	5.3	110	15	6.4	15°	08NR/L..		230070	230053		●	●
SNR/L0008K08	11	8	6.6	125	15	7							●	●
SNR/L0008K11	11	8	6	125	15	7							●	●
SNR/L0010K11	13	10	7.2	125	18	9	15°	11NR/L..		230075	230054		●	●
SNR/L0012M11	16	12	8.7	150	18	11							●	●
SNR/L0013N11	15	13	8	160	18	12							●	●
SNR/L0016Q11	18	16	9.5	180	20	15							●	●
SNR/L0013N16	17	13	10.2	160	25	12							●	●
SNR/L0014N16	17	14	9.5	160	25	13							●	●
SNR/L0016Q16	20	16	11.5	180	25	14.6							●	●
SNR/L0018Q16	21	18	11.5	180	25	16.8							●	●
SNR/L0020R16	24	20	13.5	200	28	18.4	15°	16NR/L..		230086	230057		●	●
SNR/L0025S16	29	25	16	250	32	23.4							●	●
SNR/L0032T16	36	32	19.5	300	38	30							●	●
SNR/L0040T16	44	40	23.5	300	42	38		230032	230033	230087	230079		●	●
SNR/L0050U16	54	50	28.5	350	50	48							●	●
SNR/L0020R22	24	20	13.5	200	32	18.4							●	●
SNR/L0025S22	31	25	18	250	32	23.4							●	●
SNR/L0032T22	38	32	21.5	300	38	30	15°	22NR/L..	230032	230098	230057	230079	●	●
SNR/L0040T22	46	40	25.5	300	42	38							●	●
SNR/L0050U22	56	50	30.5	350	50	48							●	●

Carbide Steel Shock-Proof Toolholder (Shock-Proof Effect > 8 Times Toolholder Diameter)

Ordering code	øD _{min}	ød	f	L	L1	H	α°	Insert	Shim	Screw	Wrench	Screw	Stock	
SIR0005H-06C-6.4	6.4	5	4.3	100	15	4.5		06NR/L..		230066	230052		●	●
SIR0008K-08C-09-20	9	8	5	125	20	7		08NR/L..		230070	230052		●	●
SIR0008K-08C-10-20	10	8	5.5	125	20	7							●	●
SIR0008K-08C-10	10	8	5.9	125	20	7							●	●
SIR0010M-11C-12	12	10	7.4	150	20	9		11NR/L..		230074	230054		●	●
SIR0012M-11C-15	15	12	8.5	150	20	11							●	●
SIR0016M-16C-19	19	16	11.7	150	25	14.6		16NR/L..		230086	230057		●	●
SIR0016R-16C-19	19	16	11.7	200	25	14.6							●	●
SIR0020R-16C-24	24	20	13.7	200	30	18.4							●	●
SIR0020S-16C-24	24	20	13.7	250	30	18.4							●	●
SIR0025S-16C-29	29	25	16.2	250	35	23.4							●	●

Spring Steel Shock-Proof Toolholder (Shock-Proof Effect > 4 Times Toolholder Diameter)

Ordering code	øD _{min}	ød	f	L	L1	H	α°	Insert	Shim	Screw	Clamp	Screw	Wrench	Stock
T-SNR0006J06	8	6	4	110	12	5.4		06NR/L..		230066		230118	230052	●
T-SNR0006K06-A10	8	10	4	125	25	9		08NR/L..		230070		230118	230052	●
T-SNR0007J08	10	7	5.3	110	12	6.2		11NR/L..		230074		230119	230054	●
T-SNR0008K08	10	8	5.5	125	12	7							●	
T-SNR0008K11	10	8	6	125	15	7							●	
T-SNR0010K11	12	10	6.6	125	15	9							●	
T-SNR0012M11	16	12	6.8	150	15	11							●	
T-SNR0013N16	18	13	9	160	22	12		16NR/L..		230086		230118	230057	●
T-SNR0016Q16	20	16	10.5	180	25	15							●	
T-SNR0020R16	25	20	13.5	200	30	18.4							●	
T-SNR0025S16	30	25	16.5	250	35	23.4							●	

High-Speed Steel Shock-Proof Toolholder (Shock-Proof Effect > 5 Times Toolholder Diameter)

Ordering code	øD _{min}	ød	f	L	L1	H	α°	Insert	Shim	Screw	Clamp	Screw	Wrench	Stock
HNR0006J06	8	6	4	110	12	5.4		06NR/L..		230066		230118	230052	●
HNR0006K06-A10	8	10	4	125	25	9		08NR/L..		230070		230118	230052	●
HNR0007J08	10	7	5.3	110	12	6.2		11NR/L..		230074		230119	230054	●
HNR0008K08	10	8	5.5	125	12	7							●	
HNR0008K11	10	8	6	125	15	7							●	
HNR0010K11	12	10	6.6	125	15	9							●	
HNR0012M11	16	12	6.8	150	15	11							●	
HNR0013N16	18	13	9	160	22	12		16NR/L..		230086		230118	230057	●
HNR0016Q16	20	16	10.5	180	25	15							●	
HNR0020R16	25	20	13.5	200	30	18.4							●	
HNR0025S16	30	25	16.5	250	35	23.4							●	

TTIR 60°/55° Internal Hole Thread Processing

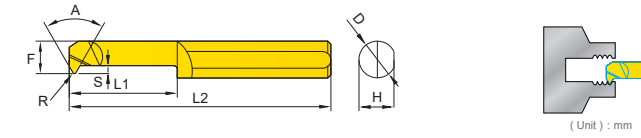

Model	F	L1	S	R	D	L2	American	Metric	Pitch	Processing Diameter	α	
TTIR 14050-60°	1.4	5.0	0.4	0.00	D4	50	UN-1, UN-2	M2	0.25	0.45	1.5mm	60°
18070-60°	1.9	7.0	0.6	0.00	D4	50	UN-3, UN-4	M2.5	0.25	0.7	1.5mm	60°
24070-60°	2.4	7.0	0.5	0.00	D4	50	UN-5, UN-6	M3	0.35	0.5	2.0mm	60°
30120-60°	3.0	12.0	0.85	0.03	D4	50	UN-8, UN-10	M4	0.5	0.8	3.0mm	60°
40150-60°	3.85	15.0	1.1	0.05	D4	50	UN-12, UN-14	M5/M6	0.5	1.0	4.0mm	60°
50150-60°	4.8	15.0	1.5	0.05	D5	50	UN1/4, UN5/16	M8	0.75	1.5	5.0mm	60°
60200-60°	5.6	20.0	1.8	0.08	D6	50	UN1/4, G1/16	M10	0.75	1.75	6.0mm	60°
80220-60°	7.8	22.0	2.2	0.08	D8	50	UN5/16, G1/8	M12	1.0	2.0	8.0mm	60°

55° Profile Angle Inch Thread

Model	F	L1	S	R	D	L2	American	Metric	Pitch	Processing Diameter	α
TTIR 40150-55°	3.85	15.0	1.1	0.05	D4	50	1/4-20SSW			4.0mm	55°
50150-55°	4.8	15.0	1.5	0.05	D5	50	5/16-18SSW			5.0mm	55°
60200-55°	5.6	20.0	1.8	0.08	D6	50	3/8-16SSW/G1/8x1/16			6.0mm	55°
80220-55°	7.8	22.0	2.2	0.08	D8	50	1/2-12SSW/G1/4x1/8			8.0mm	55°

60° Reverse Thread

Model	F	L1	S	R	D	L2	American	Metric	Pitch	Processing Diameter	α	
TTIR 40150-60°	3.85	15.0	1.1	0.05	D4	50	UN-12, UN-14	M5/M6	0.5	1.0	4.0mm	60°
50150-60°	4.8	15.0	1.5	0.05	D5	50	UN1/4, UN5/16	M8	0.75	1.5	5.0mm	60°
60200-60°	5.6	20.0	1.8	0.08	D6	50	UN1/4, G1/16	M10	0.75	1.75	6.0mm	60°
80220-60°	7.8	22.0	2.2	0.08	D8	50	UN5/16, G1/8	M12	1.0	2.0	8.0mm	60°

SNR

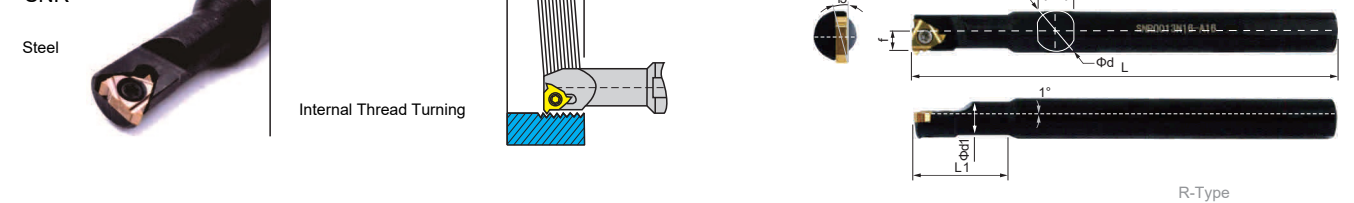

Ordering code	Dimensions							Insert	Screw	Wrench	Stock	
	øD _{min}	ød	f	L	L1	H	α°				R	L
SINR/L0612K06-15	6.4	12	4.3	125	12	11		06NR/L..	230066	230052	●	●
SNR/L0816K08-18	8	16	5	125	18	14.6		08NR/L..	230070	230053	●	●
SNR/L0010K11-A16	12	16	7.2	125	20	14.6	15°	11NR/L..	230074	230054	●	●
SNR/L0012M11-A16	15	16	8.7	150	25	14.6					●	●
SNR/L0013N16-A16	16	16	10	160	25	14.6		16NR/L..	230086	230057	●	●
SNR/L1516M16-A16	15	16	8.5	150	30	14.6					●	●

CNR

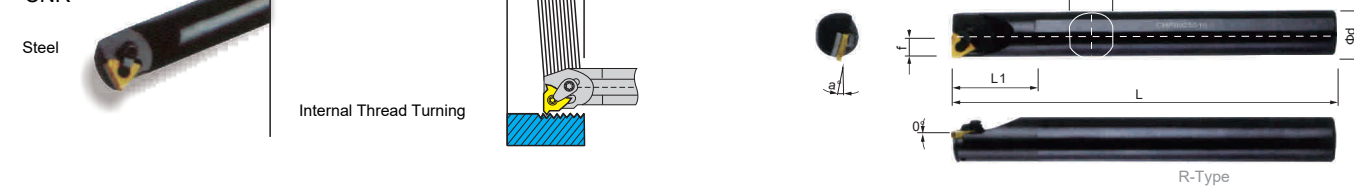

Ordering code	Dimensions							Insert	Shim	Screw	Clamp	Screw	Wrench	Stock	
	ΦD	Φd	f	L	L1	H	α°							R	L
CNR/L0025S16	29	25	16	250	32	23.4		16NR/L..	230032	230084		230118	230057	●	●
CNR/L0032T16	36	32	19.5	300	38	30						230119	230047	●	●
CNR/L0040T16	44	40	23.5	300	42	38								●	●
CNR/L0050U16	54	50													

External / internal thread turning tool

API RD

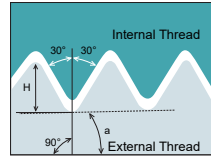

Thread Application: Threads for petroleum and natural gas industries

Material	Cutting Environment	Stable Cutting	General Cutting	General Cutting (Second recommend)	Unstable Cutting	PCD1	CBN1	CBN2	PM30	PM30	PM30	PM30	PM30	PM30	PM30	PM30	PM30	PM30	PM30
P Steel	Stable Cutting	●	●	●	●	●	●	●	●	●	●	●	●	●	●	●	●	●	●
M Stainless Steel	General Cutting	●	●	●	●	●	●	●	●	●	●	●	●	●	●	●	●	●	●
K Iron	General Cutting	●	●	●	●	●	●	●	●	●	●	●	●	●	●	●	●	●	●
N Aluminum/Copper/Magnesium/Zinc/Plastic/Wood	General Cutting	●	●	●	●	●	●	●	●	●	●	●	●	●	●	●	●	●	●
S Carbide/Powder Metallurgy	General Cutting	●	●	●	●	●	●	●	●	●	●	●	●	●	●	●	●	●	●
H Titanium/Superalloy/Carbon Fiber	General Cutting	●	●	●	●	●	●	●	●	●	●	●	●	●	●	●	●	●	●

Application	Dimensioning	Specification	Pitch (tpi)	Dimension (mm)	PCD1	CBN1	CBN2	PM30	PM30	PM30	PM30	PM30	PM30	PM30	PM30	PM30	PM30	PM30	PM30
External thread processing		22ER 10APIRD-4 8APIRD-3	10	4 1.47 0.18 17.1	●	●	●	●	●	●	●	●	●	●	●	●	●	●	●

Application	Dimensioning	Specification	Pitch (tpi)	Dimension (mm)	PCD1	CBN1	CBN2	PM30	PM30	PM30	PM30	PM30	PM30	PM30	PM30	PM30	PM30	PM30	PM30
Internal thread processing		22IR 10APIRD-4 8APIRD-3	10	4 1.47 0.18 17.1	●	●	●	●	●	●	●	●	●	●	●	●	●	●	●

BUT

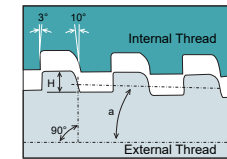

Inserts	Applicable specification of threaded pipe
5BUT75	4-1/2"~13-3/8"
5BUT1	16"~20"

Thread Application: Thread for petroleum trapezoidal casing

Application	Dimensioning	Specification	Pitch (tpi)	Dimension (mm)	PCD1	CBN1	CBN2	PM30	PM30	PM30	PM30	PM30	PM30	PM30	PM30	PM30	PM30	PM30	PM30
External thread processing		22ER 5BUT75-2	5	2 0.75 2.05 16.8	●	●	●	●	●	●	●	●	●	●	●	●	●	●	●
External thread processing		27ER 5BUT75-3	5	3 0.75 2.46 21.9	●	●	●	●	●	●	●	●	●	●	●	●	●	●	●

Application	Dimensioning	Specification	Pitch (tpi)	Dimension (mm)	PCD1	CBN1	CBN2	PM30	PM30	PM30	PM30	PM30	PM30	PM30	PM30	PM30	PM30	PM30	PM30
Internal thread processing		22IR 5BUT75-2	5	2 0.75 1.14 16.65	●	●	●	●	●	●	●	●	●	●	●	●	●	●	●
Internal thread processing		27IR 5BUT75-3	5	3 0.75 2.46 21.9	●	●	●	●	●	●	●	●	●	●	●	●	●	●	●

SIR . . S . .

Steel

Square Shank
Internal Thread Turning

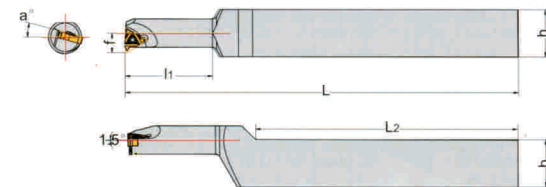
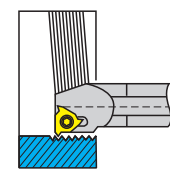

R-Type

Ordering code	Dimensions								Insert	Screw	Wrench	Stock	
	øD _{min}	ød	f	L	L1	h	b	α°				R	L
SIR/L 0007M08-S20	10	7	5.3	150	22	20	20	08IR/L..	230071	230052	●	●	
0008M08-S20	11	8	5.8	150	25	20	20				●	●	
0010M11-S20	12	10	7.4	150	31	20	20	11IR/L..	230074	230054	●	●	
0012P11-S20	15	12	8.4	170	37	20	20				●	●	
0013P16-S20	16	13	10.2	170	40	20	20	16IR/L..	230083	230057	●	●	
0016Q16-S20	19	16	11.7	180	49	20	20				●	●	
0007M08-S25	10	7	5.3	150	22	25	25	15° 08IR/L..	230071	230052	●	●	
0008M08-S25	11	8	5.8	150	25	25	25				●	●	
0010M11-S25	12	10	7.4	150	31	25	25	11IR/L..	230074	230054	●	●	
0012M11-S25	15	12	8.4	150	37	25	25				●	●	
0016Q16-S25	19	16	11.7	180	49	25	25	16IR/L..	230083	230057	●	●	
0020R16-S25	24	20	13.7	200	61	25	25				●	●	
0020R22-S25	24	20	15.6	200	61	25	25	22IR/L..	230093	230057	●	●	

PER . .

Lever locking type

Petroleum pipe external thread processing

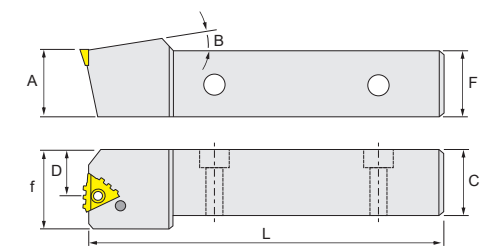

Note: E is the tool helix angle

Lever	Lever Screw	Wrench
230061-1	230106	230048

R-Type

Ordering code	Dimensions								Processing Range	Insert	Shim	Stock	
	L	f	A	B	C	D	E	F				R	L
PER 2525-175-B17A	175	29	25	5°	25	21.5	70°	25	2-3/8"~3-1/2"	22ER10RD2-4	230038	○	○
3232-175-B17A	175	38	32	5°	32	26.5	70°	32				○	○
3232-175-B17B	175	38	32	5°	32	26.5	50°	32	4"~5-1/2"	22ER8RD2-3	230038	○	○
3232-175-B17C	175	38	32	5°	32	26.5	30°	32				○	○
3232-175-B17D	175	38	32	5°	32	26.5	15°	32	6-5/8"~8-5/8"	22ER8RD2-3	230038	○	○
4040-175-B17D	175	40	40	5°	40	26.5	15°	40				○	○
3232-175-B17B-10	175	38	32	10°	32	25	60°	32	9-5/8"~13-3/8"	22ER5BU2-2	230038	○	○
3232-175-B17C-10	175	38	32	10°	32	25	40°	32				○	○
3232-175-B17D-10	175	38	32	10°	32	25	20°	32	7"~11-1/2"	22ER5BU2-2	230038	○	○
4040-175-B17D-10	175	40	40	10°	40	25	20°	40				○	○
3240-175-B23B-10	175	38	32	10°	32	25	60°	32	13-3/8"~20"	27ER5BU2-3	230039	○	○
3240-175-B23C-10	175	38	32	10°	32	25	40°	32				○	○
3240-175-B23D-10	175	38	32	10°	32	25	20°	32	4-1/2"~6-5/8"	27ER5BU2-3	230039	○	○
4040-175-B23D-10	175	40	40	10°	40	25	20°	40				○	○

TER . .

Clamp locking type

Petroleum pipe external thread processing

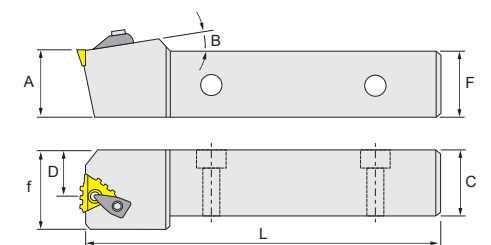

Note: E is the tool helix angle

Clamp	Clamp Screw	Spring	Shim Screw	Pin	Clamp Wrench	Shim Wrench
230124	230103	230150	230090	230017	230048	230057

R-Type

Ordering code	Dimensions								Processing Range	Insert	Shim	Stock	
	L	f	A	B	C	D	E	F				R	L
TER 2525-175-B17A	175	29	25	5°	25	21.5	70°	25	2-3/8"~3-1/2"	22ER10RD2-4	230042	○	○
3232-175-B17A	175	38	32	5°	32	26.5	70°	32				○	○
3232-175-B17B	175	38	32	5°	32	26.5	50°	32	4"~5-1/2"	22ER8RD2-3	230042	○	○
3232-175-B17C	175	38	32	5°	32	26.5	30°	32				○	○
3232-175-B17D	175	38	32	5°	32	26.5	15°	32	6-5/8"~8-5/8"	22ER8RD2-3	230042	○	○
4040-175-B17D	175	40	40	5°	40	26.5	15°	40				○	○
3232-175-B17B-10	175	38	32	10°	32	25	60°	32	9-5/8"~13-3/8"	22ER5BU2-2	230042	○	○
3232-175-B17C-10	175	38	32	10°	32	25	40°	32				○	○
3232-175-B17D-10	175	38	32	10°	32	25	20°	32	7"~11-1/2"	22ER5BU2-2	230042	○	○
4040-175-B17D-10	175	40	40	10°	40	25	20°	40				○	○
3240-175-B23B-10	175	38	32	10°	32	25	60°	32	13-3/8"~20"	27ER5BU2-3	230043	○	○
3240-175-B23C-10	175	38	32	10°	32	25	40°	32				○	○
3240-175-B23D-10	175	38	32	10°	32	25	20°	32	4-1/2"~6-5/8"	27ER5BU2-3	230043	○	○
4040-175-B23D-10	175	40	40	10°	40	25	20°	40				○	○

External / internal thread turning tool

PNR .

Lever locking type

Petroleum pipe internal thread processing



Note: E is the tool helix angle

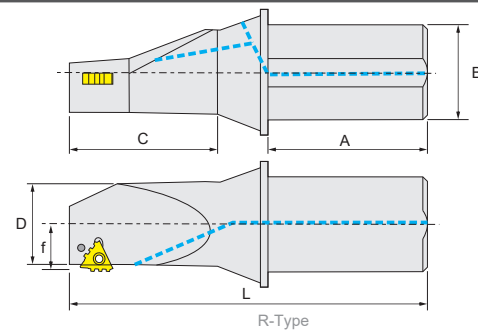

Ordering code	Dimensions								Processing Range	Insert	Shim	Stock	
	L	f	A	B	C	D	E	R				L	
PNR 0040-205-B17A	205	26	80	40	100	42	70°	2-3/8"~3-1/2"	22IR10RD2-4	230040	○	○	
0050-220-B17A	220	26	90	50	105	42	70°				○	○	
0060-225-B17A	225	26	100	60	100	42	70°				○	○	
0080-280-B17A	280	26	150	80	105	42	70°				○	○	
0040-235-B17B	235	31	80	40	130	50	50°	4"~5-1/2"	22IR8RD2-3	230040	○	○	
0050-273-B17B	273	36	90	50	158	56	50°				○	○	
0060-273-B17B	273	36	90	60	158	56	50°				○	○	
0080-300-B17B	300	36	140	80	158	56	50°				○	○	
0060-278-B17C	278	36	100	60	158	56	30°	6-5/8"~8-5/8"	22IR5BU2-2	230040	○	○	
0080-318-B17C	318	36	140	80	158	56	30°				○	○	
0060-295-B17D	295	43	100	60	175	60	15°				○	○	
0080-335-B17D	335	43	140	80	175	60	15°				○	○	
PNR 0050-273-B23B	273	36	90	50	158	56	50°	4"~5-1/2"	27IR5BU2-3	230041	○	○	
0060-273-B23B	255	36	90	60	158	56	50°				○	○	
0080-300-B23B	300	36	140	80	158	56	50°				○	○	
0060-278-B23C	278	36	100	60	158	56	30°				○	○	
0080-318-B23C	318	36	140	80	158	56	30°	6-5/8"~8-5/8"	27IR8RD2-5	230041	○	○	
0060-295-B23D	295	43	100	60	175	60	15°				○	○	
0080-335-B23D	335	43	140	80	175	60	15°				○	○	

TNR .

Clamp locking type

Petroleum pipe internal thread processing



Note: E is the tool helix angle

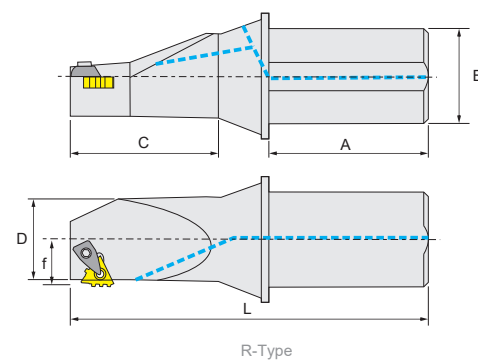

Ordering code	Dimensions								Processing Range	Insert	Shim	Stock	
	L	f	A	B	C	D	E	R				L	
TNR 0040-205-B17A	205	26	80	40	100	42	70°	2-3/8"~3-1/2"	22IR10RD2-4	230044	○	○	
0050-220-B17A	220	26	90	50	105	42	70°				○	○	
0060-225-B17A	225	26	100	60	100	42	70°				○	○	
0080-280-B17A	280	26	150	80	105	42	70°				○	○	
0040-235-B17B	235	31	80	40	130	50	50°	4"~5-1/2"	22IR8RD2-3	230044	○	○	
0050-273-B17B	273	36	90	50	158	56	50°				○	○	
0060-273-B17B	273	36	90	60	158	56	50°				○	○	
0080-300-B17B	300	36	140	80	158	56	50°				○	○	
0060-278-B17C	278	36	100	60	158	56	30°	6-5/8"~8-5/8"	22IR5BU2-2	230044	○	○	
0080-318-B17C	318	36	140	80	158	56	30°				○	○	
0060-295-B17D	295	43	100	60	175	60	15°				○	○	
0080-335-B17D	335	43	140	80	175	60	15°				○	○	
TNR 0050-273-B23B	273	36	90	50	158	56	50°	4"~5-1/2"	27IR5BU2-3	230045	○	○	
0060-273-B23B	255	36	90	60	158	56	50°				○	○	
0080-300-B23B	300	36	140	80	158	56	50°				○	○	
0060-278-B23C	278	36	100	60	158	56	30°				○	○	
0080-318-B23C	318	36	140	80	158	56	30°	6-5/8"~8-5/8"	27IR8RD2-5	230045	○	○	
0060-295-B23D	295	43	100	60	175	60	15°				○	○	
0080-335-B23D	335	43	140	80	175	60	15°				○	○	

PNR .

Lever locking type

Petroleum pipe internal thread processing



Note: E is the tool helix angle

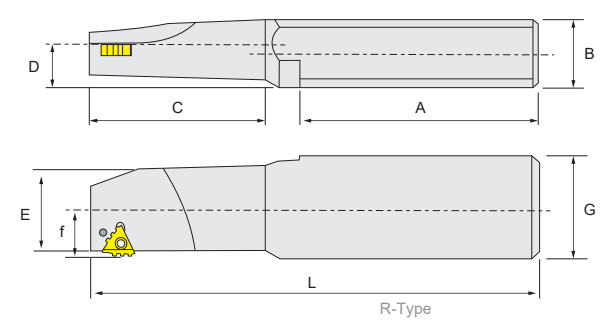

Ordering code	Dimensions								Processing Range	Insert	Shim	Stock				
	L	f	A	B	C	D	E	G				R	L			
PNR 2538-285-B17A	285	26	160	38	105	25	70°	62	2-3/8"~3-1/2"	22IR10RD2-4	230040	○	○			
3249-285-B17A	285	26	160	49	105	32	70°	62				○	○			
3249-335-B17B	335	31	180	49	130	32	50°	74.3				4"~5-1/2"	22IR8RD2-3	230040	○	○
3655-335-B17B	335	31	180	55	130	36	50°	77.2							○	○
3249-363-B17C	363	36	180	49	158	32	30°	74.3	6-5/8"~8-5/8"	22IR5BU2-2	230040	○	○			
3655-378-B17C	378	36	200	55	163	36	30°	82				○	○			
3249-400-B17D	400	52	280	49	158	32	30°	74.3				○	○			
4055-400-B17D	400	52	200	55	163	40	15°	82				○	○			
PNR 3249-335-B23B	335	31	180	49	130	32	50°	74.3	4"~5-1/2"	27IR5BU2-3	230041	○	○			
3655-335-B23B	335	31	180	55	130	36	50°	77.2				○	○			
3249-363-B23C	363	36	180	49	158	32	30°	74.3				6-5/8"~8-5/8"	27IR8RD2-5	230041	○	○
3655-378-B23C	378	36	200	55	163	36	30°	82							○	○
3249-400-B23D	400	52	280	49	158	32	30°	74.3	9-5/8"~13-3/8"		230041	○	○			
4055-400-B23D	400	52	200	55	163	40	15°	82				○	○			

TNR .

Clamp locking type

Petroleum pipe internal thread processing



Note: E is the tool helix angle

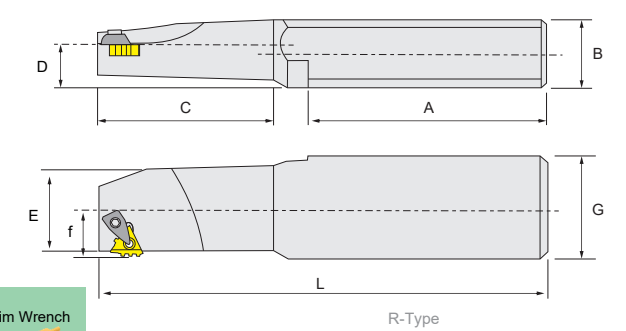

Ordering code	Dimensions								Processing Range	Insert	Shim	Stock				
	L	f	A	B	C	D	E	G				R	L			
TNR 2538-285-B17A	285	26	160	38	105	25	70°	62	2-3/8"~3-1/2"	22IR10RD2-4	230044	○	○			
3249-285-B17A	285	26	160	49	105	32	70°	62				○	○			
3249-335-B17B	335	31	180	49	130	32	50°	74.3				4"~5-1/2"	22IR8RD2-3	230044	○	○
3655-335-B17B	335	31	180	55	130	36	50°	77.2							○	○
3249-363-B17C	363	36	180	49	158	32	30°	74.3	6-5/8"~8-5/8"	22IR5BU2-2	230044	○	○			
3655-378-B17C	378	36	200	55	163	36	30°	82				○	○			
3249-400-B17D	400	52	280	49	158	32	30°	74.3				○	○			
4055-400-B17D	400	52	200	55	163	40	15°	82				○	○			
TNR 3249-335-B23B	335	31	180	49	130	32	50°	74.3	4"~5-1/2"	27IR5BU2-3	230045	○	○			
3655-335-B23B	335	31	180	55	130	36	50°	77.2				○	○			
3249-363-B23C	363	36	180	49	158	32	30°	74.3				6-5/8"~8-5/8"	27IR8RD2-5	230045	○	○
3655-378-B23C	378	36	200	55	163	36	30°	82							○	○
3249-400-B23D	400	52	280	49	158	32	30°	74.3	9-5/8"~13-3/8"		230045	○	○			
4055-400-B23D	400	52	200	55	163	40	15°	82				○	○			

SP

Cutting Environment											Stable Cutting											General Cutting											Unstable Cutting										
Application	Dimensioning	Product Image	Specification	W	FE	L	B	H	θ	PCD1	CBN1	CBN2	PM30	N021	P140	PMS40	PMS30	PCD1	CBN1	CBN2	PM30	N021	P140	PMS40	PMS30	PCD1	CBN1	CBN2	PM30	N021	P140	PMS40	PMS30										
Steel			SP 200	2.2	0.2	9.3	-	-	-	-	-	-	-	-	-	-	-	-	-	-	-	-	-	-	-	-	-	-	-	-	-	-	-										
Stainless Steel			SP 300	3.1	0.2	11.3	-	-	-	-	-	-	-	-	-	-	-	-	-	-	-	-	-	-	-	-	-	-	-	-	-	-	-										
Iron			SP 400	4.1	0.25	11.3	-	-	-	-	-	-	-	-	-	-	-	-	-	-	-	-	-	-	-	-	-	-	-	-	-	-	-	-									
Aluminum/Copper/Magnesium/Zinc/Plastic/Wood			SP 500	5.1	0.3	11.4	-	-	-	-	-	-	-	-	-	-	-	-	-	-	-	-	-	-	-	-	-	-	-	-	-	-	-	-									
Carbide/Powder Metallurgy			SP 600	6.4	0.35	11.4	-	-	-	-	-	-	-	-	-	-	-	-	-	-	-	-	-	-	-	-	-	-	-	-	-	-	-	-									
Titanium/Superalloy/Carbon Fiber			SP 200L	2.2	0.2	9.3	-	-	-	-	-	-	-	-	-	-	-	-	-	-	-	-	-	-	-	-	-	-	-	-	-	-	-	-									
Stainless Steel			SP 300L	3.1	0.2	11.3	-	-	-	-	-	-	-	-	-	-	-	-	-	-	-	-	-	-	-	-	-	-	-	-	-	-	-	-	-								
Iron			SP 400L	4.1	0.25	11.3	-	-	-	-	-	-	-	-	-	-	-	-	-	-	-	-	-	-	-	-	-	-	-	-	-	-	-	-	-								
Aluminum/Copper/Magnesium/Zinc/Plastic/Wood			SP 500L	5.1	0.3	11.4	-	-	-	-	-	-	-	-	-	-	-	-	-	-	-	-	-	-	-	-	-	-	-	-	-	-	-	-	-								
Carbide/Powder Metallurgy			SP 600L	6.4	0.35	11.4	-	-	-	-	-	-	-	-	-	-	-	-	-	-	-	-	-	-	-	-	-	-	-	-	-	-	-	-	-								
Titanium/Superalloy/Carbon Fiber			SP 200R	2.2	0.2	9.3	-	-	-	-	-	-	-	-	-	-	-	-	-	-	-	-	-	-	-	-	-	-	-	-	-	-	-	-	-								
Stainless Steel			SP 300R	3.1	0.2	11.3	-	-	-	-	-	-	-	-	-	-	-	-	-	-	-	-	-	-	-	-	-	-	-	-	-	-	-	-	-	-							
Iron			SP 400R	4.1	0.25	11.3	-	-	-	-	-	-	-	-	-	-	-	-	-	-	-	-	-	-	-	-	-	-	-	-	-	-	-	-	-	-							
Aluminum/Copper/Magnesium/Zinc/Plastic/Wood			SP 500R	5.1	0.3	11.4	-	-	-	-	-	-	-	-	-	-	-	-	-	-	-	-	-	-	-	-	-	-	-	-	-	-	-	-	-	-							
Carbide/Powder Metallurgy			SP 600R	6.4	0.35	11.4	-	-	-	-	-	-	-	-	-	-	-	-	-	-	-	-	-	-	-	-	-	-	-	-	-	-	-	-	-	-							

Lathe Cut-off Tool

ZQMX

Cutting Environment											Stable Cutting											General Cutting											Unstable Cutting										
Application	Dimensioning	Product Image	Specification	W	FE	L	B	H	θ	PCD1	CBN1	CBN2	PM30	N021	P140	PMS40	PMS30	PCD1	CBN1	CBN2	PM30	N021	P140	PMS40	PMS30	PCD1	CBN1	CBN2	PM30	N021	P140	PMS40	PMS30										
Steel			ZQMX 3N11-1E	3.1	0.3	11	-	-	-	-	-	-	-	-	-	-	-	-	-	-	-	-	-	-	-	-	-	-	-	-	-	-	-	-	-	-							
Stainless Steel			ZQMX 4N11-1E	4.1	0.3	11	-	-	-	-	-	-	-	-	-	-	-	-	-	-	-	-	-	-	-	-	-	-	-	-	-	-	-	-	-	-							
Iron			ZQMX 5N11-1E	5.1	0.3	11	-	-	-	-	-	-	-	-	-	-	-	-	-	-	-	-	-	-	-	-	-	-	-	-	-	-	-	-	-	-							
Aluminum/Copper/Magnesium/Zinc/Plastic/Wood			ZQMX 6N11-1E	6.4	0.3	11	-	-	-	-	-	-	-	-	-	-	-	-	-	-	-	-	-	-	-	-	-	-	-	-	-	-	-	-	-	-							
Carbide/Powder Metallurgy			ZQMX 7N11-1E	7.0	0.3	14	-	-	-	-	-	-	-	-	-	-	-	-	-	-	-	-	-	-	-	-	-	-	-	-	-	-	-	-	-	-							
Titanium/Superalloy/Carbon Fiber																																											

ZQZ..R.

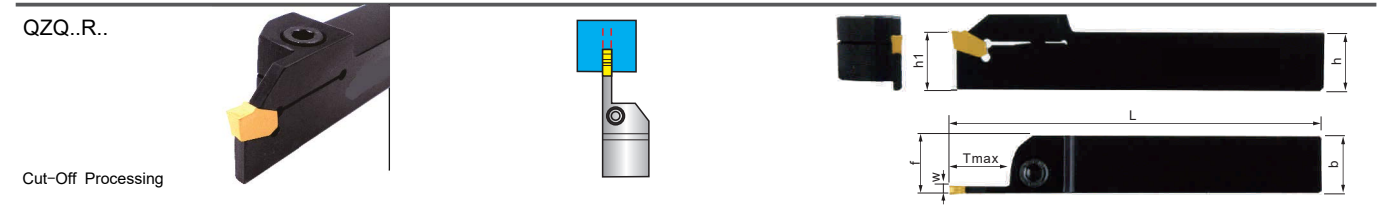

Ordering code	Dimensions							Insert	Screw	Wrench	Stock	
	W	b	h	L	h1	f	Tmax				R	L
ZQZ 1616R/L03	3	16	16	80	16	16.4	16	ZQMX3N11-1E	230103	230061	●	●
ZQZ 2020R/L03	3	20	20	100	20	20.4	20				●	●
ZQZ 2525R/L03	3	25	25	120	25	25.4	20				●	●
ZQZ 3225R/L03	3	25	32	135	32	25.4	25	ZQMX4N11-1E	230110	230062	●	●
ZQZ 1616R/L04	4	16	16	80	16	16.4	16				●	●
ZQZ 2020R/L04	4	20	20	100	20	20.4	20				●	●
ZQZ 2525R/L04	4	25	25	120	25	25.4	20	230110	230062	●	●	
ZQZ 3225R/L04	4	25	32	135	32	25.4	25			●	●	

ZQ . R

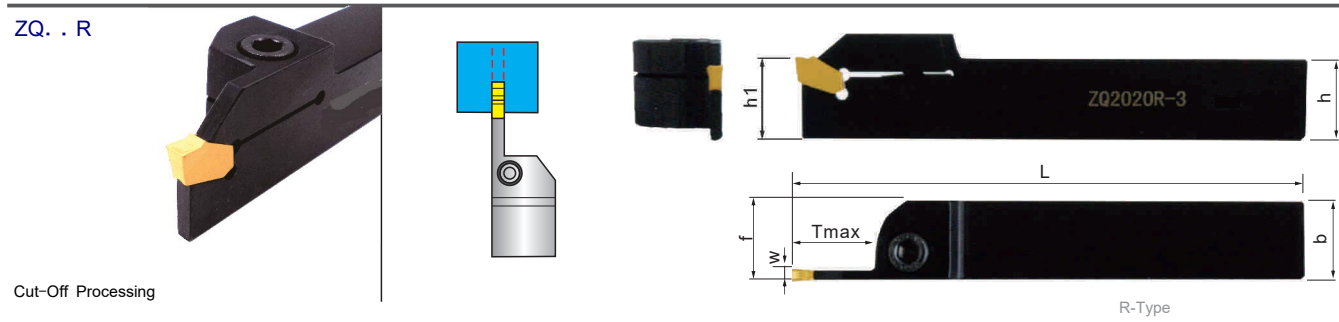

Ordering code	Dimensions							Insert	Screw	Wrench	Stock	
	W	b	h	L	h1	f	Tmax				R	L
ZQ 1616R/L-02	2.2	16	16	100	16	16.4	16	SP200	230103	230061	●	●
ZQ 2020R/L-02	2.2	20	20	125	20	20.4	16				●	●
ZQ 2525R/L-02	2.2	25	25	150	25	25.4	16				●	●
ZQ 1616R/L-03	3.125	16	16	100	16	16.4	20	SP300	230103	230061	●	●
ZQ 2020R/L-03	3.125	20	20	125	20	20.4	20				●	●
ZQ 2525R/L-03	3.125	25	25	150	25	25.4	20				●	●
ZQ 3225R/L-03	3.125	25	32	170	32	25.4	20	SP400	230107	230062	●	●
ZQ 1616R/L-04	4.125	16	16	100	16	16.4	25				●	●
ZQ 2020R/L-04	4.125	20	20	125	20	20.4	25				●	●
ZQ 2525R/L-04	4.125	25	25	150	25	25.4	25	230107	230062	●	●	
ZQ 3225R/L-04	4.125	32	32	170	32	25.4	25			●	●	
ZQ 2525R/L-05	5.125	25	25	150	25	25.5	30	SP500	230107	230062	●	●
ZQ 3232R/L-05	5.125	32	32	170	32	32.5	30				●	●
ZQ 2525R/L-06	6.4	25	25	150	25	25.5	35	SP600	230107	230062	●	●
ZQ 3232R/L-06	6.4	32	32	170	32	32.5	35				●	●

Lathe Cut-off Tool

KTKHR.

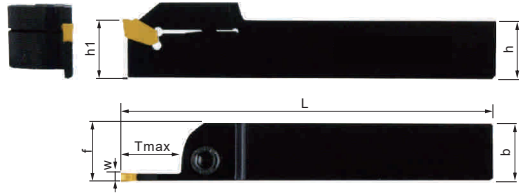
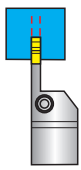

Cut-Off Processing

Ordering code	Dimensions							Insert	Screw	Wrench	Stock	
	W	b	h	L	h1	f	Tmax				R	L
KTKHR/L 1010F-2S	2.2	10	10	80	10	10	15	TKN2,TKR/L2 TKN2-P,TKR/L2-P TKN2.4,TKR/L2.4			•	•
1212H-2S	2.2	12	12	100	12	12	16.5				•	•
1612H-2S	2.2	12	16	100	16	16	16.5				•	•
1616H-2S	2.2	16	16	100	16	16	16.5				•	•
2012K-2S	2.2	12	20	125	20	20	19				•	•
2020K-2S	2.2	20	20	125	20	20	19	•	•			
KTKHR/L 1612H-3S	3.1	12	16	100	16	16	18	TKN3,TKR/L3 TKN3-P,TKR/L3-P			•	•
1616H-3S	3.1	16	16	100	16	16	18				•	•
2012K-3S	3.1	12	20	125	20	20	20.5				•	•
2020K-3S	3.1	20	20	125	20	20	26				•	•
2525M-3S	3.1	25	25	150	25	25	26.5				•	•
KTKHR/L 2012K-4S	4.1	12	20	125	20	20	22	TKN4,TKR/L4			•	•
2020K-4S	4.1	20	20	125	20	20	31				•	•
2525M-4S	4.1	25	25	150	25	25	34				•	•
KTKHR/L 2525M-5S	5.1	25	25	150	25	25	39.5	TKN4.8,TKN5,TKR/L5			•	•

Automatic Lathe With Self-locking

KTKHR/L 1010K-2-125S	2.2	10	10	125	10	10	15	TKN2,TKR/L2				•	•
1212M-2-125S	2.2	12	12	150	12	12	15	TKN2-P,TKR/L2-P				•	•
1616M-2-150S	2.2	16	16	150	16	16	18	TKN2.4,TKR/L2.4				•	•
KTKHR/L 1616M-3-150S	3.1	16	16	150	16	16	22.5	TKN3,TKR/L3 TKN3-P,TKR/L3-P			•	•	

Automatic Lathe With Screw Fastening

KTKHR/L 0808K-1.6-125B	1.6	8	8	125	8	8	5		230093	230057		•	•
1010K-1.6-125B	1.6	10	10	125	10	10	10					•	•
1212M-1.6-150B	1.6	12	12	150	12	12	12.5					•	•
1414M-1.6-150B	1.6	14	14	150	14	14	13					•	•
KTKHR/L 1010K-2-125B	2.2	10	10	125	10	10	10	TKN2,TKR/L2	230093	230057		•	•
1212M-2-150B	2.2	12	12	150	12	12	12.5	TKN2-P,TKR/L2-P				•	•
1616M-2-150B	2.2	16	16	150	16	16	16	TKN2.4,TKR/L2.4				230101	230061
KTKHR/L 1616M-3-150B	3.1	16	16	150	16	16	16	TKN3,TKR/L3 TKN3-P,TKR/L3-P	230101	230061	•	•	

UGHR/L Cut-Off Processing Toolholder

UGHR/L 1616H2	2.2	16	16	16	16	16.3	16	KGT2	230103	230061		•	•
2020K2	2.2	20	20	20	20	20.3	21					230107	230062
UGHR/L 1616H3	3.1	16	16	16	16	16.4	18	KGT3	230103	230061		•	•
2020K3	3.1	20	20	20	20	20.4	29					•	•
2525M3	3.1	25	25	25	25	25.4	38					•	•
UGHR/L 2525M4	4.1	25	25	25	25	25.5	38	KGT4	230107	230062	•	•	

CTWR/L Cut-Off Processing Toolholder

CTWR/L 2020-3	3	20	20	20	20	20.25	14	CTD3	230107	230062		•	•
2525-3	3	25	25	25	25	25.25	14					•	•
CTWR/L 2020-4	4	20	20	20	20	20.25	14	CTD4	230107	230062		•	•
2525-4	4	25	25	25	25	25.25	14					•	•
CTWR/L 2525-5	5	25	25	25	25	25.25	20	CTD5	230107	230062	•	•	

CGSSR/L Cut-Off Processing Toolholder

CGSSR/L 1616-30D	3	16	16	16	16	16.5	22	GE30,GE30R/L	230107	230062		•	•
2020-30D	3	20	20	20	20	20.5	22	GE30-AL,GT30				•	•
2525-30D	3	25	25	25	25	25.5	22	GR30				•	•
CGSSR/L 1616-40D	4	16	16	16	16	16.6	25	GE40,GE40R/L	230107	230062		•	•
2020-40D	4	20	20	20	20	20.6	25	GE40-AL,GT40				•	•
2525-40D	4	25	25	25	25	25.6	25	GR40				•	•
CGSSR/L 1616-50D	5	16	16	16	16	16.7	25	GE50,GE50R/L	230107	230062		•	•
2020-50D	5	20	20	20	20	20.7	25	GE50-AL,GT50				•	•
2525-50D	5	25	25	25	25	25.7	25	GR50				•	•

Cut-Off Toolholder



Cut-Off Processing

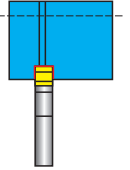

Ordering code	Dimensions					Insert	Stock
	w	b	h	L	h1		
SPB 26-2	2	1.6	26	26	21	SP200,200R/L	•
26-3	3	2.4	26	26	21	SP300,300R/L	•
26-4	4	3.2	26	26	21	SP400,400R/L	•
26-5	5	4.2	26	26	21	SP500,500R/L	•
SPB 32-2	2	1.6	32	32	27	SP200,200R/L	•
32-3	3	2.4	32	32	27	SP300,300R/L	•
32-4	4	3.2	32	32	27	SP400,400R/L	•
32-5	5	4.2	32	32	27	SP500,500R/L	•
32-6	6	5.2	32	32	27	SP600,600R/L	•

UGHN Cut-Off Processing Toolholder

UGHN 262	2.2	1.60	26	110	21.4	KGT2N,KGT2R/L	•
263	3.1	2.35	26	110	21.4	KGT3N,KGT3R/L	•
264	4.1	3.20	26	110	21.4	KGT4N,KGT4R/L	•
265	5.1	4.00	26	110	21.4	KGT5N,KGT5R/L	•
UGHN 322	2.2	1.60	32	150	25.0	KGT2N,KGT2R/L	•
323	3.1	2.35	32	150	25.0	KGT3N,KGT3R/L	•
324	4.1	3.20	32	150	25.0	KGT4N,KGT4R/L	•
325	5.1	4.00	32	150	25.0	KGT5N,KGT5R/L	•

KTKB Cut-Off Processing Toolholder

KTKB 19-1SS	1.6	1.2	19	86	15.7	TKN1.6,TKR/L1.6	•
KTKB 26-1SS	1.6	1.2	26	110	21.4	TKN1.6,TKR/L1.6	•
KTKB 32-1SS	1.6	1.2	32	150	25	TKN1.6,TKR/L1.6	•
KTKB 19-2S	2.2	1.8	19	86	15.7	TKN2,TKR/L2	•
26-2S	2.2	1.8	26	110	21.4	TKN2,TKR/L2	•
26-3S	3.1	2.6	26	110	21.4	TKN3,TKR/L3	•
26-4S	4.1	3.4	26	110	21.4	TKN4,TKR/L4	•
26-5S	5.1	4.2	26	110	21.4	TKN5,TKR/L5	•
KTKB 32-2S	2.2	1.8	32	150	25	TKN2,TKR/L2	•
32-3S	3.1	2.6	32	150	25	TKN3,TKR/L3	•
32-4S	4.1	3.4	32	150	25	TKN4,TKR/L4	•
32-5S	5.1	4.2	32	150	25	TKN5,TKR/L5	•
32-6S	6.4	5.4	32	150	25	TKN6,TKR/L6	•
KTKBR/L 32-8S	8.0	6.8	32	150	25	TKN8,TKR/L8	•
32-9S	9.6	8.0	32	150	25	TKN9,TKR/L9	•

SCTH Cut-Off Processing Toolholder

SCTH 26-3	3	2.2	25.35	110	21.16	GT30	•
26-4	4	3.2	25.14	110	21.05	GT40	•
SCTH 32-3	3	2.2	31.41	150	24.8	GT30	•
32-4	4	3.2	31.14	150	24.66	GT40	•
32-5	5	4.2	30.87	150	24.53	GT50	•
32-6	6	5.2	30.61	150	24.39	GT60	•

SLTBN Cut-Off Toolholder

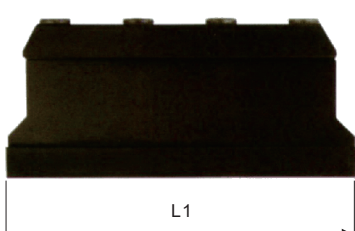
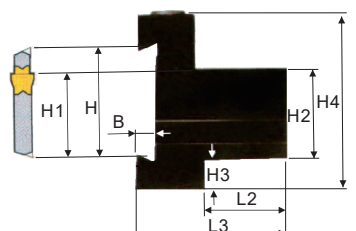
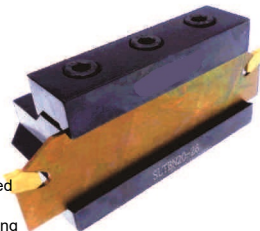

Features:
Tools for modular cutting can be combined with corresponding blades according to customer requirements, and the processing depth can be adjusted.

Ordering code	Dimensions									Screw	Wrench	Stock
	H	H1	H2	H3	H4	B	L1	L2	L3			
SLTBN 16-26	26	21.4	16	13	43	5.3	86	12	30	230111	230062	•
20-26	26	21.4	20	9	43	5.3	86	19	38			•
20-32	32	24.8	20	13	50	5.3	100	19	38			•
SLTBN 25-26	26	21.4	25	5	45	5.3	100	23	42	•	•	
25-32	32	24.8	25	8	50	5.3	110	23	42	•	•	
SLTBN 32-32	32	24.8	32	5	54	5.3	110	29	48	•	•	

External / Internal Grooving turning tool

MGIVR

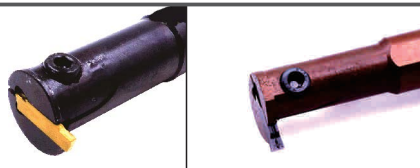

Internal Grooving Processing

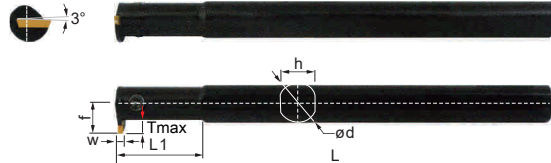
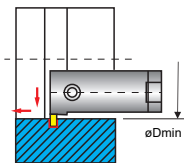

R-Type

Ordering code	Dimensions							Screw	Wrench	Insert	Stock				
	W	Tmax	ϕd	f	L	L1	h				R	L			
MGIVR/L 2016-1.5	1.5	3.5	16	12.4	160	35	14.8	230094	230060	MGMN150 MGGN150 MRMN150	●	●			
2016-1.5T8	1.5	8	16	12.4	160	38	14.8				●	●			
2520-1.5	1.5	3.5	20	14	180	45	18.4				230103	230061	MGMN200 MGGN200 MRMN200	●	●
2520-1.5T8	1.5	8	20	14	180	45	18.4							●	●
2925-1.5	1.5	3.5	25	17.25	200	50	23.4							●	●
2925-1.5T8	1.5	8	25	17.25	200	50	23.4	●	●						
MGIVR/L 2016-2	2	4.5	16	12.4	160	35	14.8	230094	230060	MGMN200 MGGN200 MRMN200	●	●			
2016-2T8	2	8	16	12.4	160	38	14.8				●	●			
2520-2	2	4.5	20	14	180	45	18.4				230103	230061	MGMN250 MGGN250 MRMN250	●	●
2520-2T8	2	8	20	14	180	45	18.4							●	●
2925-2	2	4.5	25	17.25	200	45	23.4							●	●
2925-2T8	2	8	25	17.25	200	50	23.4	●	●						
3732-2T8	2	8	32	20.5	250	70	30	230107	230062	●	●				
MGIVR/L 2016-2.5	2.5	4.5	16	12.4	160	35	14.8	230094	230060	MGMN250 MGGN250 MRMN250	●	●			
2016-2.5T8	2.5	8	16	13.25	160	38	14.8				●	●			
2520-2.5	2.5	4.5	20	15.6	180	45	18.4				230103	230061	MGMN300 MGGN300 MRMN300	●	●
2520-2.5T8	2.5	8	20	16	180	45	18.4							●	●
2925-2.5	2.5	4.5	25	18.9	200	45	23.4							●	●
2925-2.5T8	2.5	8	25	17.5	200	50	23.4	●	●						
3732-2.5T8	2.5	8	32	20.5	250	70	30	230107	230062	●	●				
MGIVR/L 2016-3	3	5	16	14.5	160	35	14.8	230094	230060	MGMN300 MGGN300 MRMN300	●	●			
2016-3T8	3	8	16	15	160	38	14.8				●	●			
2316-3	3	6	16	15.6	160	35	14.8				●	●			
2520-3	3	6	20	15.6	180	45	18.4				230103	230061	MGMN400 MGGN400 MRMN400	●	●
2520-3T8	3	8	20	15.6	180	45	18.4							●	●
3125-3	3	6	25	18.9	200	50	23.4	●	●						
3125-3T10	3	10	25	18.9	200	50	23.4	●	●						
3732-3	3	6	32	21.5	250	65	30	230107	230062	MGMN500 MGGN500 MRMN500	●	●			
3732-3T12	3	12	32	21.5	250	65	30				●	●			
4540-3	4	8	40	27.2	300	70	38				230113	230153	MGMN600 MRMN600	●	●
4540-3T15	4	15	40	27.2	300	70	38							●	●
MGIVR/L 2016-4	4	6	16	15	160	35	14.8							230094	230060
2016-4T8	4	8	16	15	160	38	14.8	●	●						
2520-4	4	6	20	15.6	180	45	18.4	230103	230061	MGMN500 MGGN500 MRMN500	●	●			
2520-4T8	4	8	20	15.6	180	45	18.4				●	●			
3125-4	4	6	25	18.9	200	50	23.4				●	●			
3125-4T10	4	10	25	18.9	200	50	23.4				●	●			
3732-4	4	6	32	21.5	250	65	30	230107	230062	MGMN600 MRMN600	●	●			
3732-4T12	4	12	32	21.5	250	65	30				●	●			
4540-4	4	8	40	27.2	300	70	38				230113	230153	MGMN800 MRMN800	●	●
4540-4T15	4	15	40	27.2	300	70	38							●	●
MGIVR/L 3125-5	5	8	25	19.4	200	50	23.4							230103	230061
3125-5T10	5	10	32	19.4	200	50	23.4	●	●						
3732-5	5	8	32	21.5	250	65	30	230107	230062	MGMN800 MRMN800	●	●			
3732-5T12	5	12	32	21.5	250	65	30				●	●			
4540-5	5	10	40	27.2	300	70	38				230113	230153	MGMN800 MRMN800		
4540-5T15	5	15	40	27.2	300	70	38							●	●
MGIVR/L 3125-6	6	8	25	19.4	200	50	23.4	230103	230061	MGMN800 MRMN800				●	●
3125-6T10	6	10	32	19.4	200	50	23.4							●	●
3732-6	6	8	32	21.5	250	65	30				230107	230062	MGMN800 MRMN800	●	●
3732-6T12	6	12	32	21.5	250	65	30							●	●
MGIVR/L 3732-8	8	10	32	23.5	250	65	30							230107	230062
3732-8T12	8	12	32	23.5	250	65	30	●	●						
4540-8	8	10	40	27.2	300	70	38	230113	230153	MGMN800 MRMN800	●	●			
4540-8T15	8	15	40	27.2	300	70	38				●	●			

MGEHR..R
(Circular arc strengthening type)

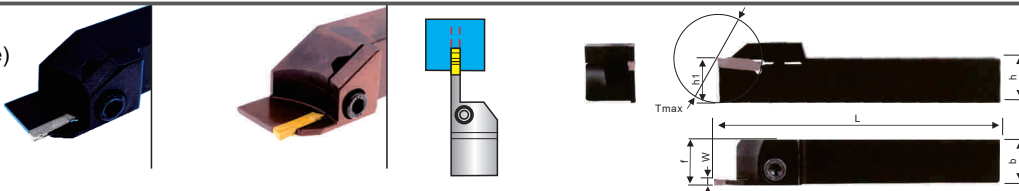

External Cut-Off/Grooving

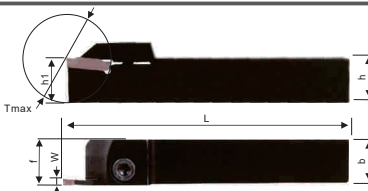

R-Type

Ordering code	Dimensions							Insert	Screw	Wrench	Stock		Order Number		
	W	b	h	L	h1	f	Tmax				R	L			
MGEHR/L 1010-1.5R	1.5	10	10	100	10	10	15	MGMN150 MGGN150 MRMN150	230095	230060	●	●	252170		
1212-1.5R	1.5	12	12	100	12	12	15				●	●	252172		
1616-1.5R	1.5	16	16	100	16	16	15				230103	230061	●	●	252174
2020-1.5R	1.5	20	20	125	20	20	15	MGMN200 MGGN200 MRMN200	230107	230062	●	●	252176		
1010-2R	2	10	10	100	10	10	16				●	●	252178		
1212-2R	2	12	12	100	12	12	16				●	●	252180		
1616-2R	2	16	16	100	16	16	16				230103	230061	●	●	252182
2020-2R	2	20	20	125	20	20	16	MGMN/MGGN300 MRMN300	230107	230062	●	●	252184		
1616-3R	3	16	16	100	16	16	20				230103	230061	●	●	252186
2020-3R	3	20	20	125	20	20	20				230107	230062	●	●	252188

MGEVR

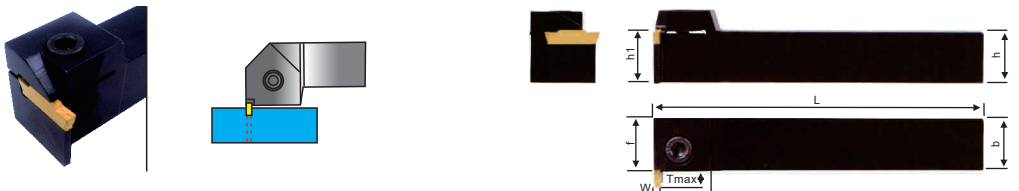

External Cut-Off Processing

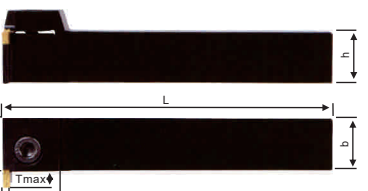

R-Type

Ordering code	Dimensions							Screw	Wrench	Insert	Stock			
	W	b	h	L	h1	f	Tmax				R	L		
MGEVR/L 1616-1.5	1.5	16	16	100	16	21.3	5	230103	230061	MGMN150 MGGN150 MRMN150	●	●		
2020-1.5	1.5	20	20	125	20	26.3	6	230107	230062		●	●		
2525-1.5	1.5	25	25	150	25	33	6	230103	230061		●	●		
MGEVR/L 1616-2	2	16	16	100	16	21.3	5	230103	230061	MGMN200 MGGN200 MRMN200	●	●		
1616-2T10	2	16	16	100	16	26.2	10				●	●		
2020-2	2	20	20	125	20	26.3	6				230107	230062	●	●
2020-2T11	2	20	20	125	20	31.5	11				230103	230061	●	●
2525-2	2	25	25	150	25	33	6				230107	230062	●	●
MGEVR/L 1616-2.5	2.5	16	16	100	16	21.3	5	230103	230061	MGMN250 MGGN250 MRMN250	●	●		
2020-2.5	2.5	20	20	125	20	26.3	6				●	●		
2525-2.5	2.5	25	25	150	25	33	7				230107	230062	●	●
MGEVR/L 1616-3	3	16	16	100	16	21.3	7	230103	230061	MGMN300 MGGN300 MRMN300	●	●		
1616-3T13	3	16	16	100	16	29.5	13				●	●		
2020-3	3	20	20	125	20	26.3	7				230107	230062	●	●
2020-3T15	3	20	20	125	20	35.5	15				230103	230061	●	●
2525-3	3	25	25	150	25	33	7				230107	230062	●	●
2525-3T15	3	25	25	150	25	40.5	15	230103	230061	●	●			
MGEVR/L 1616-4	4	16	16	100	16	21.3	7	230103	230061	MGMN400 MGGN400 MRMN400	●	●		
1616-4T13	4	16	16	100	16	29.5	13				●	●		
2020-4	4	20	20	125	20	26.3	7				230107	230062	●	●
2020-4T15	4	20	20	125	20	35.5	15				230103	230061	●	●
2525-4	4	25	25	150	25	33	7				230107	230062	●	●
2525-4T15	4	25	25	150	25	40.5	15	230103	230061	●	●			
MGEVR/L 2020-5T														

TD

External / Internal Grooving turning tool

Application	Dimensioning	Product Image	Specification	Dimension							Application							
				W	rc	L	B	H	φ	PCDN	CBN2	PM30	PM40	PM50	PM60	PM70	PM80	PM90
External Grooving			TDC 2 3 4 5 6 8	2.0	0.2	20.0	1.7	4.7	-	-	•	•	•	•	•	•	•	•
				3.0	0.2	20.0	2.4	4.7	-	-	•	•	•	•	•	•	•	•
External Grooving			TDC 2-6R 2-8R 2-15R 3-6R 3-15R 4-4R 4-15R 5-4R	2.0	0.2	20.0	1.7	4.7	6°	-	•	•	•	•	•	•	•	
				3.0	0.2	20.0	2.4	4.7	15°	-	•	•	•	•	•	•	•	•
External Grooving			TSC 2 3 4 5 6 8	2.0	0.2	20.0	1.7	4.7	-	-	•	•	•	•	•	•	•	
				3.0	0.2	20.0	2.4	4.7	-	-	•	•	•	•	•	•	•	•

TTIR

External Cut-Off/Grooving

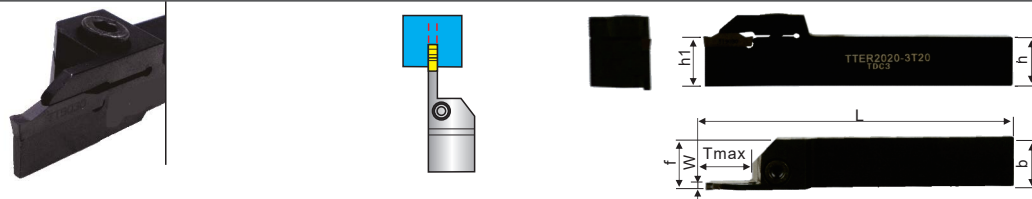

Ordering code	Dimensions							Insert	Screw	Wrench	Stock	
	W	b	h	L	h1	f	Tmax				R	L
TTIR/L 1010-1.4T15-D40	1.4	10	10	125	10	9.5	40	TDJ1.4	230103	230061	○	○
1212-1.4T15-D40	1.4	12	12	125	12	11.5	40				○	○
1616-1.4T20-D45	1.4	16	16	125	16	15.5	45				○	○
2020-1.4T20-D45	1.4	20	20	125	20	19.5	45				○	○
TTIR/L 1010-2T15-D40	2	10	10	125	10	9.1	40	TDC2 TSC2 TDJ2	230107	230062	○	○
1212-2T15-D40	2	12	12	125	12	11.1	40				○	○
1616-2T20-D45	2	16	16	125	16	15.1	45				○	○
2020-2T20-D45	2	20	20	125	20	19.1	45				○	○
TTIR/L 1212-3T15-D40	3	12	12	125	12	10.8	40	TDC3,TSC3 TDJ3 TDXU3,TDT3	230107	230062	○	○
1616-3T20-D45	3	16	16	125	16	14.8	45				○	○
2020-3T20-D45	3	20	20	125	20	18.8	45				○	○
2525-3T20-D45	3	25	25	150	25	23.8	45				○	○
TTIR/L 1616-2	2	16	16	110	16	15.1	12	TDC2,TSC2 TDJ2	230107	230062	●	○
2020-2	2	20	20	125	20	19.1	12				●	○
2525-2	2	25	25	150	25	24.1	12				●	○
TTIR/L 1616-3	3	16	16	110	16	14.8	12	TDC3,TSC3 TDJ3,TDXU3 TDT3	230107	230062	●	○
2020-3	3	20	20	125	20	18.8	12				●	○
2525-3	3	25	25	150	25	23.8	12				●	○
TTIR/L 1616-4	4	16	16	110	16	14.5	15	TDC4,TSC4 TDJ4,TDXU4 TDT4	230107	230062	●	○
2020-4	4	20	20	125	20	18.5	15				●	○
2525-4	4	25	25	150	25	23.5	15				●	○
TTIR/L 2020-5	5	20	20	125	20	18.1	20	TDC5,TSC5,TDJ5 TDXU5,TDT5	230107	230062	●	○
2525-5	5	25	25	150	25	23.1	20				●	○
TTIR/L 2020-6	6	20	20	125	20	17.6	20	TDC6,TSC6,TDJ6 TDXU6,TDT6	230107	230062	●	○
2525-6	6	25	25	150	25	22.6	20				●	○
TTIR/L 2525-8	8	25	25	150	25	22.1	25	TDC8,TSC8 TDXU8,TDT8	230107	230062	●	○
3232-8	8	32	32	170	32	29.1	25				●	○
TTIR/L 2525-10T25	10	25	25	150	25	21.1	25	TDT10	230113	230153	○	○
3232-10T40	10	32	32	170	32	28.1	40				○	○
4040-10T40	10	40	40	200	40	36.1	40				○	○

TTIR

Internal Grooving Processing

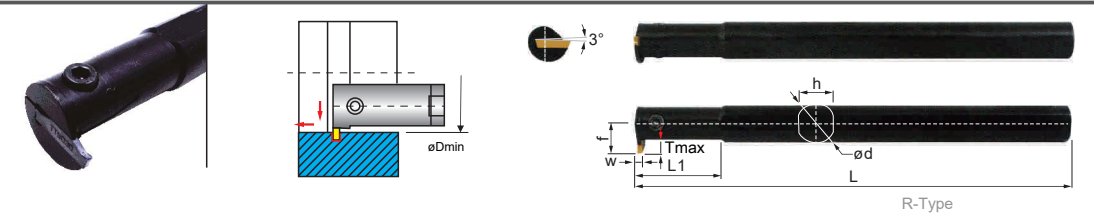

Ordering code	Dimensions							Screw	Wrench	Insert	Stock	
	W	Tmax	ød	f	L	L1	h				R	L
TTIR/L 16-2C	2	8.5	16	16.5	160	40	14.8	230095	230060	TDC2 TSC2 TDJ2	●	●
16-2T8	2	8.0	16	12.4	160	38	14.8				●	●
20-2C	2	6.0	20	15.8	160	40	18.4	230103	230061		●	●
20-2T8	2	8.0	20	14	160	45	18.4				●	●
25-2C	2	5.0	25	17.5	200	40	23.4				●	●
25-2T8	2	8.0	25	17.25	200	50	23.4	230110	230062		●	●
32-2T8	2	8.0	32	20.5	250	70	30			●	●	
TTIR/L 16-3T8	3	8.0	16	15	160	38	14.8	230095	230060	TDC3 TSC3 TDJ3 TDXU3 TDT3	●	●
20-3C	3	6.0	20	15.8	160	40	18.4				●	●
20-3T8	3	8.0	20	15.6	160	45	18.4	230103	230061		●	●
25-3C	3	5.1	25	17.5	200	40	23.4				●	●
25-3C-T8	3	8.0	25	21.5	200	40	23.4				●	●
25-3T10	3	10	25	18.9	200	50	23.4	230110	230062		●	●
32-3C	3	4.7	32	19.8	250	60	30			●	●	
32-3C-T10	3	10	32	27	250	60	30	230110	230062	●	●	
32-3T12	3	12	32	21.5	250	65	30			●	●	
40-3C-T12	3	12	40	33	300	65	38			●	●	
40-3T15	3	15	40	27.2	300	70	38	230095	230060	●	●	
TTIR/L 16-4T8	4	8.0	16	15	160	38	14.8			230103	230061	TDC4,TSC4 TDJ4,TDXU4 TDT4
20-4C	4	6.0	20	15.8	160	40	18.4	●	●			
20-4T8	4	8.0	20	15.6	160	45	18.4	●	●			
25-4C	4	5.2	25	17.5	200	40	23.4	●	●			
25-4C-T8	4	8.0	25	21.5	200	40	23.4	●	●			
25-4T10	4	10	25	18.9	200	50	23.4	●	●			
32-4C	4	4.7	32	20.8	250	60	30	230110	230062	●	●	
32-4C-T10	4	10	32	27	250	60	30			●	●	
32-4T12	4	12	32	21.5	250	65	30			●	●	
40-4C-T12	4	12	40	33	300	65	38	230110	230062	●	●	
40-4T15	4	15	40	27.2	300	70	38			●	●	
50-4C-T15	4	15	50	40	350	70	48	230103	230061	TDC5,TSC5 TDJ5 TDXU5,TDT5	○	○
TTIR/L 25-5C	5	5.2	25	17.3	200	40	23.4				○	○
32-5C	5	4.7	32	20.8	250	60	30				○	○
32-5C-T10	5	10	32	27	250	60	30				○	○
40-5C-T12	5	12	40	33	300	65	38	230110	230062	○	○	
50-5C-T14	5	14	50	40	350	70	48			○	○	
TTIR/L 32-6C	6	4.7	32	20.8	250	60	30	230110	230062	TDC6,TSC6 TDJ6 TDXU6,TDT6	○	○
32-6C-T10	6	10	32	27	250	60	30				○	○
40-6C-T12	6	12	40	33	300	65	38				○	○
50-6C-T14	6	14	50	40	350	70	48				○	○
TTIR/L 32-8C	8	5.5	32	21.3	250	60	30	230110	230062	TDC8,TSC8 TDXU8,TDT8	○	○
40-8C	8	5.8	40	25.8	300	65	38				○	○



External / Internal Grooving turning tool

Cutting Environment										Cutting Environment													
Stable Cutting										Stable Cutting													
General Cutting										General Cutting													
Unstable Cutting										Unstable Cutting													
P	Steel	●	●	●	●	●	●	●	●	●	P	Steel	●	●	●	●	●	●	●	●	●	●	●
M	Stainless Steel	●	●	●	●	●	●	●	●	●	M	Stainless Steel	●	●	●	●	●	●	●	●	●	●	●
K	Iron	●	●	●	●	●	●	●	●	●	K	Iron	●	●	●	●	●	●	●	●	●	●	●
N	Aluminum/Copper/Magnesium/Zinc/Plastic/Wood	●	●	●	●	●	●	●	●	●	N	Aluminum/Copper/Magnesium/Zinc/Plastic/Wood	●	●	●	●	●	●	●	●	●	●	●
S	Carbide/Powder Metallurgy	●	●	●	●	●	●	●	●	●	S	Carbide/Powder Metallurgy	●	●	●	●	●	●	●	●	●	●	●
H	Titanium/Superalloy/Carbon Fiber	●	●	●	●	●	●	●	●	●	H	Titanium/Superalloy/Carbon Fiber	●	●	●	●	●	●	●	●	●	●	●

Application	Dimensioning	Product Image	Specification	Dimension								PCD1	CBN1	CBN2	PM300	PM400	PM130	PM340	PM350					
				W	re	L	B	H	φ	φ	φ													
External Grooving			GMM1520-T21 2020-T21 2520-T21 3020-T21	1.5	0.0	20	1.2	4.3	-	-	-	-	●	●	●	●	●	●	●	●				
				2.0	0.0	20	1.5	4.3	-	-	-	-	-	●	●	●	●	●	●	●	●			
				2.5	0.0	20	1.9	4.3	-	-	-	-	-	●	●	●	●	●	●	●	●	●		
				3.0	0.0	20	2.3	4.3	-	-	-	-	-	●	●	●	●	●	●	●	●	●		
External Grooving			GMM3020-020-G26 3020-040-G26 4020-020-G26 4020-040-G26 4020-080-G26 5020-040-G26 5020-080-G26 6020-040-G26 6020-080-G26 8030-080-G26	3.0	0.2	20	2.3	4.3	-	-	-	●	●	●	●	●	●	●	●	●				
				3.0	0.4	20	2.3	4.3	-	-	-	-	●	●	●	●	●	●	●	●	●	●		
				4.0	0.2	20	3.3	4.3	-	-	-	-	-	●	●	●	●	●	●	●	●	●	●	
				4.0	0.4	20	3.3	4.3	-	-	-	-	-	●	●	●	●	●	●	●	●	●	●	●
External Grooving			GMM3020-150R 4020-200R 5020-250R 6020-300R	3.0	1.5	20	2.3	4.3	-	-	-	●	●	●	●	●	●	●	●	●				
				4.0	2.0	20	3.3	4.3	-	-	-	-	●	●	●	●	●	●	●	●	●	●	●	
				5.0	2.5	20	4.2	4.3	-	-	-	-	-	●	●	●	●	●	●	●	●	●	●	●
				6.0	3.0	20	5.2	4.3	-	-	-	-	-	●	●	●	●	●	●	●	●	●	●	●

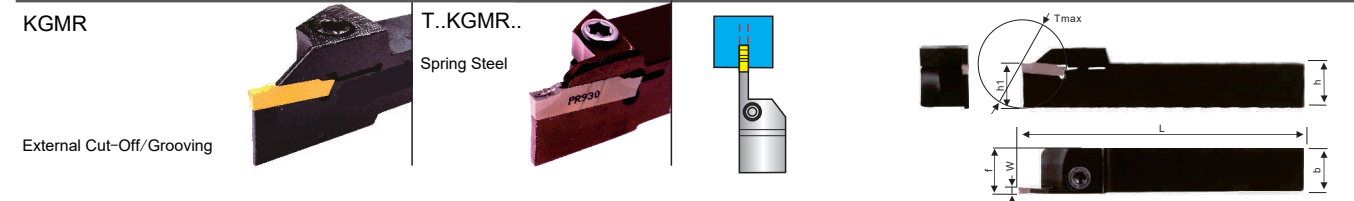

Ordering code	Dimensions							Insert	Screw	Wrench	Stock	
	W	b	h	L	h1	f	Tmax				R	L
KGMR/L 2012K-2T17	2	12	20	125	20	11.15	17	GMM2420 GMM2020R/L	230103	230061	●	●
2020K-2T17	2	20	20	125	20	19.15	17				●	●
2525M-2T17	2	25	25	150	25	24.15	17				●	●
KGMR/L 1212H-3	3	12	12	100	12	10.8	9	GMM3020 GMG3030 GMM3020R/L	230107	230062	●	●
1616H-3	3	16	16	100	16	14.8	9				●	●
2020K-3	3	20	20	125	20	18.8	9				●	●
2525M-3	3	25	25	150	25	23.8	9				●	●
1616H-3T20	3	16	16	100	16	14.8	20				●	●
2012K-3T20	3	12	20	125	20	10.8	20				●	●
2020K-3T20	3	20	20	125	20	18.8	20				●	●
2525M-3T20	3	25	25	150	25	23.8	20	●	●			
KGMR/L 2020K-4	4	20	20	125	20	18.3	10	GMM4020 GMG4030 GMM4020R/L	230107	230062	●	●
2525M-4	4	25	25	150	25	23.3	10				●	●
2020K-4T20	4	20	20	125	20	18.3	20				●	●
2525M-4T20	4	25	25	150	25	23.3	20				●	●
2525M-4T25	4	25	25	150	25	23.3	25				●	●
KGMR/L 2020K-5	5	20	20	125	20	17.8	10	GMM5020 GMG5030 GMM5020R/L	230107	230062	●	●
2525M-5	5	25	25	150	25	22.8	10				●	●
3232P-5	5	32	32	170	32	29.8	10				●	●
2525M-5T25	5	25	25	150	25	22.8	25				●	●
3232P-5T25	5	32	32	170	32	29.8	25				●	●
KGMR/L 2525M-6T30	6	25	25	150	25	22.4	30	GMM6020, GMG6030 GMM6020R/L	230107	230062	●	●
KGMR/L 2525M-8	8	25	25	150	25	22.0	25	GMM8020 GMG8030 GMM8020R/L	230107	230062	●	●
3232P-8	8	32	32	170	32	29.0	25				●	●

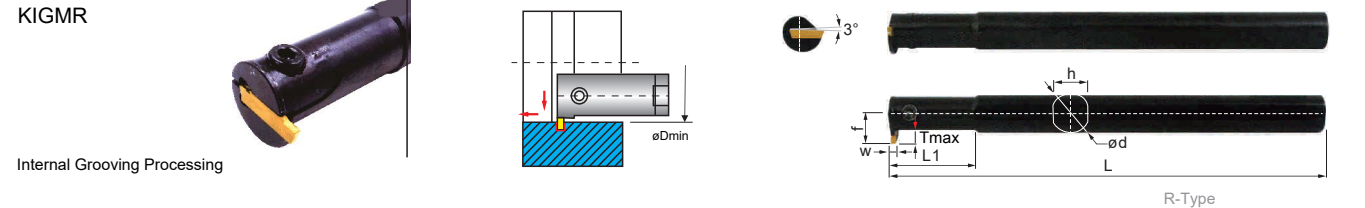

Ordering code	Dimensions							Insert	Screw	Wrench	Stock	
	W	Tmax	φd	f	L	L1	h				R	L
KIGM R/L 2016B-3V	3	5.5	16	11.5	150	25	15	GMM30, GMG30	230094	230060	●	●
2520B-3V	3	6.0	20	14.5	180	32	18				●	●
3225B-3V	3	8.0	25	19	200	40	23				●	●
KIGM R/L 3225B-4V	4	8.5	25	19	180	40	23	GMM40, GMG40 GMM50, GMG50	230110	230062	●	●
4032B-4V	4	11.0	32	23.5	200	50	29				●	●

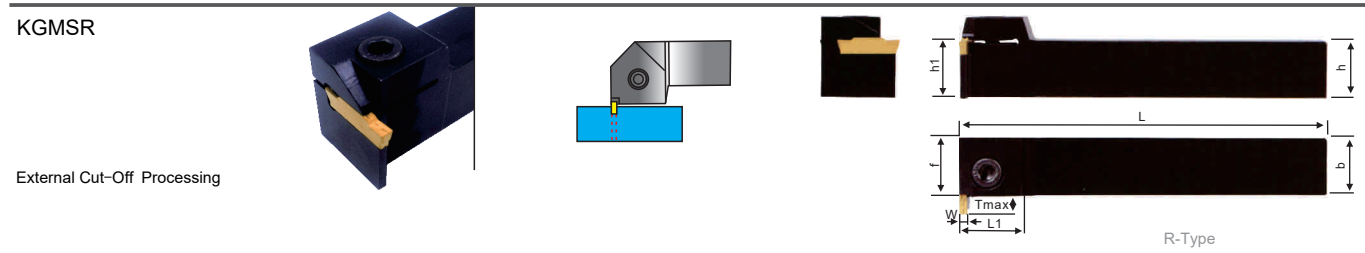

Ordering code	Dimensions							Insert	Screw	Wrench	Stock	
	W	b	h	L	h1	f	Tmax				R	L
KGMSR/L 1212H-3	3	12	12	100	12	17	4.8	GMM3020 GMG3030 GMM3020R/L	230103	230061	●	●
1616H-3	3	16	16	100	16	21.5	4.8				●	●
2020K-3	3	20	20	125	20	25	4.8				●	●
2525M-3	3	25	25	150	25	30	4.8				●	●

Used Of Automatic Lathe

Ordering code	Dimensions							Insert	Screw	Wrench	Stock	
	W	Tmax	φd	f	L	L1	h				R	L
KGMR/L 0810K-1.5-125	1.5	10	8	125	8	9.4	5	GMM1520 GMM1520R/L	230103	230061	●	●
1010K-1.5-125	1.5	10	10	125	10	9.4	10				●	●
1212F-1.5-85	1.5	12	12	85	12	11.4	12.5				●	●
1212M-1.5-150	1.5	12	12	150	12	11.4	12.5				●	●
KGMR/L 0810K-2-125	2	10	8	125	8	9.2	5	GMM2420 GMM2020R/L	230103	230061	●	●
1010K-2-125	2	10	10	125	10	9.15	10				●	●
1212F-2-85	2	12	12	85	12	11.15	12.5				●	●
1212M-2-150	2	12	12	150	12	11.15	12.5				●	●
1616M-2-150	2	16	16	150	16	15.15	16				●	●
KGMR/L 1010K-2.5-125	2.5	10	10	125	10	9	10	GMM2520 GMM2520R/L	230103	230061	●	●
1212F-2.5-85	2.5	12	10	85	10	11	12.5				●	●
1212M-2.5-150	2.5	12	12	150	12	11	12.5				●	●
1616M-2.5-150	2.5	16	16	150	16	15	16				●	●
KGMR/L 1616M-3-150	3	16	16	150	16	14.8	16				GMM3020, GMG3030 GMM3020R/L	230107

Spring Steel Shock-Proof Toolholder (Shock-Proof Effect > 4 Times Toolholder Diameter)

Ordering code	Dimensions							Insert	Screw	Wrench	Stock	
	W	Tmax	φd	f	L	L1	h				R	L
T-KGMR/L 1010J-1.5T12	1.5	10	10	110	10	10	12	GMM1520 GMM1520R/L	230103	230061	●	●
1212G-1.5T12	1.5	12	12	90	12	12	12				●	●
1212J-1.5T12	1.5	12	12	110	12	12	12				●	●
1616G-1.5T15	1.5	16	16	90	16	16	15				●	●
2020K-1.5T15	1.5	20	20	125	20	20	15				●	●
T-KGMR/L 1010J-2T12	2	10	10	110	10	10	12	GMM2420 GMM2020R/L	230103	230061	●	●
1212G-2T12	2	12	12	90	12	12	12				●	●
1212J-2T12	2	12	12	110	12	12	12				●	●
1616H-2T17	2	16	16	100	16	16	17				●	●
1616J-2T12	2	16	16	110	16	16	12				●	●
2020K-2T12	2	20	20	125	20	20	12				●	●
T-KGMR/L 1616H-3T20	3	16	16	100	16	16	20	GMM3020 GMG3030 GMM3020R/L	230107	230062	●	●
2020K-3T20	3	20	20	125	20	20	20				●	●
2525M-3T20	3	25	25	150	25	25	20				●	●
T-KGMR/L 2525M-4T20	4	25	25	150	25	25	20	GMM4020R/L	230107	230062	●	●

Z..

External / Internal Grooving turning tool

(Cutting Speed): m/min¹ (mm)

Material Characteristics	PCD1	CBN1	CBN2	PM30	PM15	N021	P140	P130	P141	PMS40	PMS30	HRC60 High Speed	K140	K130
P Low-Carbon steel				150-600	150-800		70-500	150-500	150-600	70-250	100-250	80-300		
High-Carbon steel				150-350	150-500		70-250	80-350	100-400	70-150	80-150	60-200		
Hardened Steel			10-30							20-60	20-60	20-80		
M Stainless Steel				200-300	200-350					50-150	70-150	50-200		
K Gray Cast Iron		300-1500		100-300	100-350								200-300	200-350
Ductile Iron		400-800		100-200	100-250								150-200	150-250
N Magnesium/Zinc/Plastic/Wood	300-1200					300-1200								
Aluminum Alloy	300-1500					300-1500								
Hardened Aluminum Alloy	300-800													
Copper/Bronze/Brass	300-1000					300-1000								
S Carbide/Powder Metallurgy	10-30					10-30						20-50		
Silicon Filled Plastic Hard Fiber	400-600					400-600								
H Titanium/Superalloy/Carbon Fiber	100-200					100-200				20-50	20-60	30-80		

Application	Dimensioning	Product Image	Specification	Dimension																					
				W	re	L	B	H	θ	PCD1	CBN1	CBN2	PM30	PM15	N021	P140	P130	P141	PMS40	PMS30					
External Grooving			ZTED 02503-G16	2.5	0.3	17	-	-	-	-	-	-	-	-	-	-	-	-	-	-	-				
			0303-G16	3.0	0.3	17	-	-	-	-	-	-	-	-	-	-	-	-	-	-	-	-			
			0404-G16	4.0	0.4	22	-	-	-	-	-	-	-	-	-	-	-	-	-	-	-	-	-		
			0504-G16	5.0	0.4	22	-	-	-	-	-	-	-	-	-	-	-	-	-	-	-	-	-		
			0608-G16	6.0	0.8	22	-	-	-	-	-	-	-	-	-	-	-	-	-	-	-	-	-	-	
			0608-G16	6.0	0.8	22	-	-	-	-	-	-	-	-	-	-	-	-	-	-	-	-	-	-	
Internal Grooving			ZRED 025-G16	2.5	1.25	17.5	-	-	-	-	-	-	-	-	-	-	-	-	-	-	-	-			
			03-G16	3.0	1.5	17	-	-	-	-	-	-	-	-	-	-	-	-	-	-	-	-	-		
			04-G16	4.0	2.0	21	-	-	-	-	-	-	-	-	-	-	-	-	-	-	-	-	-	-	
			05-G16	5.0	2.5	20	-	-	-	-	-	-	-	-	-	-	-	-	-	-	-	-	-	-	
			06-G16	6.0	3.0	19	-	-	-	-	-	-	-	-	-	-	-	-	-	-	-	-	-	-	-
			06-G16	6.0	3.0	19	-	-	-	-	-	-	-	-	-	-	-	-	-	-	-	-	-	-	-

QE.D..R

External Cut-Off/Grooving

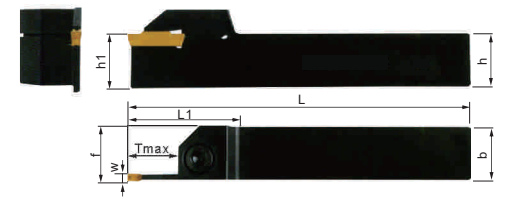
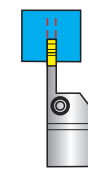
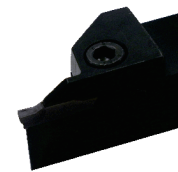

R-Type

Ordering code	Dimensions							Insert	Screw	Wrench	Stock	
	W	b	h	L	h1	f	Tmax				R	L
QECD 1616R/L15	2	16	16	100	16	16.2	15	Z.CD..	230103	230061	•	•
	2	20	20	125	20	20.2	15				•	•
QEED 1616R/L10	2.5	16	16	125	16	16.3	10	Z.ED..	230102	230061	•	•
	2.5	16	16	125	16	16.3	17				•	•
	2.5	20	20	125	20	20.3	10				•	•
	2.5	20	20	125	20	20.3	17				•	•
	2.5	25	25	150	25	25.3	10				•	•
	2.5	25	25	150	25	25.3	17				•	•
Qefd 1616R/L10	3	16	16	125	16	16.3	10	Z.FD..	230110	230062	•	•
	3	16	16	125	16	16.3	17				•	•
	3	20	20	125	20	20.3	10				•	•
	3	20	20	125	20	20.3	17				•	•
	3	25	25	150	25	25.3	10				•	•
	3	25	25	150	25	25.3	17				•	•
QEGD 2020R/L13	4	20	20	125	20	20.5	13	Z.GD..	230110	230062	•	•
	4	20	20	125	20	20.5	22				•	•
	4	25	25	150	25	25.5	13				•	•
	4	25	25	150	25	25.5	22				•	•
	4	32	32	170	32	32.5	13				•	•
	4	32	32	170	32	32.5	22				•	•
QEHD 2525R/L13	5	25	25	150	25	25.5	13	Z.HD..	230110	230062	•	•
	5	25	25	150	25	25.5	22				•	•
	5	32	32	170	32	32.5	13				•	•
	5	32	32	170	32	32.5	22				•	•
QEKD 2525R/L13	6	25	25	150	25	25.6	13	Z.KD..	230110	230062	•	•
	6	25	25	150	25	25.6	22				•	•
	6	32	32	170	32	32.6	13				•	•
	6	32	32	170	32	32.6	22				•	•

C..Q.DR

Profile Copying of Aluminum Wheel Hub

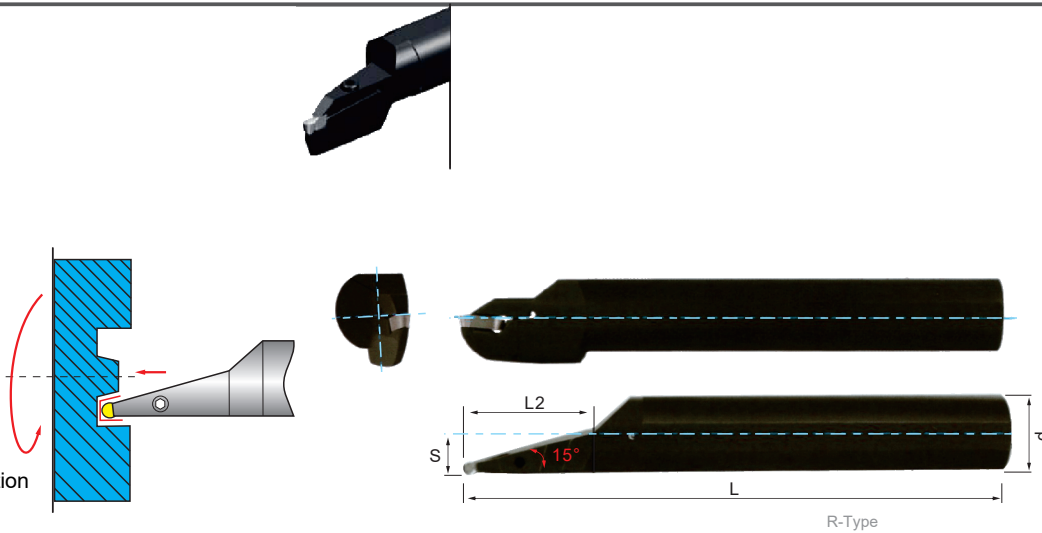

Q..DR

Internal Grooving Processing

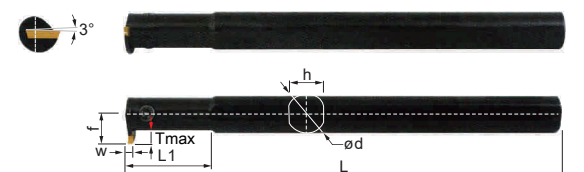
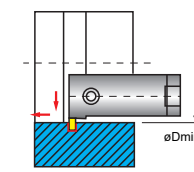

R-Type

Ordering code	Dimensions					Insert	Screw	Wrench	Stock	
	øDmin	ød	S	L1	L2				R	L
C40T-QLDR/L65-15A	160	40	21	300	65	ZRLD08-LH	230107	230062	•	•
C40T-QLDR/L80-15A	160	40	21	300	80				•	•
C50U-QLDR/L80-15A	160	50	26	350	80				•	•
C40T-QKDR/L60-15A	160	40	21	300	60	ZRKD06-LH	230107	230062	•	•
C40T-QKDR/L75-15A	160	40	21	300	75				•	•
C50U-QKDR/L75-15A	160	50	26	350	75				•	•

Ordering code	Dimensions							Insert	Screw	Wrench	Stock	
	ød	L	f	W	Tmax	L1	øDmin				R	L
C20Q-QEDR/L05-27	20	180	15.2	2.5	5	40	27	ZTED025..	230093	230060	•	•
C25R-QEDR/L07-33	25	200	20.3	2.5	7	45	33				•	•
C32S-QEDR/L09-42	32	250	25.3	2.5	9	58	42				•	•
C20Q-QFDR/L05-27	20	180	15.2	3	5	40	27	ZTFD03..	230093	230060	•	•
C25R-QFDR/L07-33	25	200	20.3	3	7	45	33				•	•
C32S-QFDR/L09-42	32	250	25.3	3	9	58	42				•	•
C25R-QGDR/L08-35	25	200	21.5	4	8	45	35	ZTGD04..	230102	230061	•	•
C32S-QGDR/L11-44	32	250	27.5	4	11	58	44				•	•
C40T-QGDR/L13-54	40	300	33.5	4	13	72	54				•	•
C25R-QHDR/L08-35	25	200	21.5	5	8	45	35	ZTHD05..	230102	230061	•	•
C32S-QHDR/L11-44	32	250	27.5	5	11	58	44				•	•
C40T-QHDR/L13-54	40	300	33.5	5	13	72	54				•	•
C25R-QKDR/L08-35	25	200	21.5	6	8	45	35	ZTKD06..	230102	230061	•	•
C32S-QKDR/L11-44	32	250	27.5	6	11	58	44				•	•
C40T-QKDR/L13-54	40	300	33.5	6	13	72	54				•	•

GY

Cutting Environment																																																																																																																																																																	
● Stable Cutting ● General Cutting ✖ Unstable Cutting																																																																																																																																																																	
Application																																																																																																																																																																	
<table border="1"> <tr><td>P</td><td>Steel</td><td>●</td><td>●</td><td>●</td><td>●</td><td>●</td><td>●</td><td>●</td><td>●</td><td>●</td><td>●</td></tr> <tr><td>M</td><td>Stainless Steel</td><td>●</td><td>●</td><td>●</td><td>●</td><td>●</td><td>●</td><td>●</td><td>●</td><td>●</td><td>●</td></tr> <tr><td>K</td><td>Iron</td><td>●</td><td>●</td><td>●</td><td>●</td><td>●</td><td>●</td><td>●</td><td>●</td><td>●</td><td>●</td></tr> <tr><td>N</td><td>Aluminum/Copper/Magnesium/Zinc/Plastic/Wood</td><td>●</td><td>●</td><td>●</td><td>●</td><td>●</td><td>●</td><td>●</td><td>●</td><td>●</td><td>●</td></tr> <tr><td>S</td><td>Carbide/Powder Metallurgy</td><td>●</td><td>●</td><td>●</td><td>●</td><td>●</td><td>●</td><td>●</td><td>●</td><td>●</td><td>●</td></tr> <tr><td>H</td><td>Titanium/Superalloy/Carbon Fiber</td><td>●</td><td>●</td><td>●</td><td>●</td><td>●</td><td>●</td><td>●</td><td>●</td><td>●</td><td>●</td></tr> </table>												P	Steel	●	●	●	●	●	●	●	●	●	●	M	Stainless Steel	●	●	●	●	●	●	●	●	●	●	K	Iron	●	●	●	●	●	●	●	●	●	●	N	Aluminum/Copper/Magnesium/Zinc/Plastic/Wood	●	●	●	●	●	●	●	●	●	●	S	Carbide/Powder Metallurgy	●	●	●	●	●	●	●	●	●	●	H	Titanium/Superalloy/Carbon Fiber	●	●	●	●	●	●	●	●	●	●																																																																														
P	Steel	●	●	●	●	●	●	●	●	●	●																																																																																																																																																						
M	Stainless Steel	●	●	●	●	●	●	●	●	●	●																																																																																																																																																						
K	Iron	●	●	●	●	●	●	●	●	●	●																																																																																																																																																						
N	Aluminum/Copper/Magnesium/Zinc/Plastic/Wood	●	●	●	●	●	●	●	●	●	●																																																																																																																																																						
S	Carbide/Powder Metallurgy	●	●	●	●	●	●	●	●	●	●																																																																																																																																																						
H	Titanium/Superalloy/Carbon Fiber	●	●	●	●	●	●	●	●	●	●																																																																																																																																																						
Dimensioning	Product Image	Specification	Dimension				Application																																																																																																																																																										
W	FE	L	B	PCD1	PCD2	PCD3	PCD4	PCD5	PCD6	PCD7	PCD8																																																																																																																																																						
<table border="1"> <tr> <th>Dimensioning</th> <th>Product Image</th> <th>Specification</th> <th>W</th> <th>FE</th> <th>L</th> <th>B</th> <th>PCD1</th> <th>PCD2</th> <th>PCD3</th> <th>PCD4</th> <th>PCD5</th> <th>PCD6</th> <th>PCD7</th> <th>PCD8</th> </tr> <tr> <td>GY2M 0200D020N-T20</td> <td></td> <td>0250E020N-T20</td> <td>2.0</td> <td>0.2</td> <td>20.7</td> <td>19.1</td> <td>●</td> <td>●</td> <td>●</td> <td>●</td> <td>●</td> <td>●</td> <td>●</td> <td>●</td> </tr> <tr> <td>0300F020N-T20</td> <td></td> <td>0300F040N-T20</td> <td>3.0</td> <td>0.2</td> <td>20.7</td> <td>19.1</td> <td>●</td> <td>●</td> <td>●</td> <td>●</td> <td>●</td> <td>●</td> <td>●</td> <td>●</td> </tr> <tr> <td>0400G020N-T20</td> <td></td> <td>0400G040N-T20</td> <td>4.0</td> <td>0.2</td> <td>25.6</td> <td>24.1</td> <td>●</td> <td>●</td> <td>●</td> <td>●</td> <td>●</td> <td>●</td> <td>●</td> <td>●</td> </tr> <tr> <td>0500H020N-T20</td> <td></td> <td>0500H040N-T20</td> <td>5.0</td> <td>0.2</td> <td>25.6</td> <td>23.9</td> <td>●</td> <td>●</td> <td>●</td> <td>●</td> <td>●</td> <td>●</td> <td>●</td> <td>●</td> </tr> <tr> <td>0600J020N-T20</td> <td></td> <td>0600J040N-T20</td> <td>6.0</td> <td>0.2</td> <td>25.6</td> <td>23.9</td> <td>●</td> <td>●</td> <td>●</td> <td>●</td> <td>●</td> <td>●</td> <td>●</td> <td>●</td> </tr> <tr> <td>0700K020N-T20</td> <td></td> <td>0700K040N-T20</td> <td>7.0</td> <td>0.2</td> <td>25.6</td> <td>23.9</td> <td>●</td> <td>●</td> <td>●</td> <td>●</td> <td>●</td> <td>●</td> <td>●</td> <td>●</td> </tr> <tr> <td>0800L020N-T20</td> <td></td> <td>0800L040N-T20</td> <td>8.0</td> <td>0.2</td> <td>25.6</td> <td>23.9</td> <td>●</td> <td>●</td> <td>●</td> <td>●</td> <td>●</td> <td>●</td> <td>●</td> <td>●</td> </tr> <tr> <td>0900M020N-T20</td> <td></td> <td>0900M040N-T20</td> <td>9.0</td> <td>0.2</td> <td>25.6</td> <td>23.9</td> <td>●</td> <td>●</td> <td>●</td> <td>●</td> <td>●</td> <td>●</td> <td>●</td> <td>●</td> </tr> <tr> <td>1000N020N-T20</td> <td></td> <td>1000N040N-T20</td> <td>10.0</td> <td>0.2</td> <td>25.6</td> <td>23.9</td> <td>●</td> <td>●</td> <td>●</td> <td>●</td> <td>●</td> <td>●</td> <td>●</td> <td>●</td> </tr> </table>												Dimensioning	Product Image	Specification	W	FE	L	B	PCD1	PCD2	PCD3	PCD4	PCD5	PCD6	PCD7	PCD8	GY2M 0200D020N-T20		0250E020N-T20	2.0	0.2	20.7	19.1	●	●	●	●	●	●	●	●	0300F020N-T20		0300F040N-T20	3.0	0.2	20.7	19.1	●	●	●	●	●	●	●	●	0400G020N-T20		0400G040N-T20	4.0	0.2	25.6	24.1	●	●	●	●	●	●	●	●	0500H020N-T20		0500H040N-T20	5.0	0.2	25.6	23.9	●	●	●	●	●	●	●	●	0600J020N-T20		0600J040N-T20	6.0	0.2	25.6	23.9	●	●	●	●	●	●	●	●	0700K020N-T20		0700K040N-T20	7.0	0.2	25.6	23.9	●	●	●	●	●	●	●	●	0800L020N-T20		0800L040N-T20	8.0	0.2	25.6	23.9	●	●	●	●	●	●	●	●	0900M020N-T20		0900M040N-T20	9.0	0.2	25.6	23.9	●	●	●	●	●	●	●	●	1000N020N-T20		1000N040N-T20	10.0	0.2	25.6	23.9	●	●	●	●	●	●	●	●
Dimensioning	Product Image	Specification	W	FE	L	B	PCD1	PCD2	PCD3	PCD4	PCD5	PCD6	PCD7	PCD8																																																																																																																																																			
GY2M 0200D020N-T20		0250E020N-T20	2.0	0.2	20.7	19.1	●	●	●	●	●	●	●	●																																																																																																																																																			
0300F020N-T20		0300F040N-T20	3.0	0.2	20.7	19.1	●	●	●	●	●	●	●	●																																																																																																																																																			
0400G020N-T20		0400G040N-T20	4.0	0.2	25.6	24.1	●	●	●	●	●	●	●	●																																																																																																																																																			
0500H020N-T20		0500H040N-T20	5.0	0.2	25.6	23.9	●	●	●	●	●	●	●	●																																																																																																																																																			
0600J020N-T20		0600J040N-T20	6.0	0.2	25.6	23.9	●	●	●	●	●	●	●	●																																																																																																																																																			
0700K020N-T20		0700K040N-T20	7.0	0.2	25.6	23.9	●	●	●	●	●	●	●	●																																																																																																																																																			
0800L020N-T20		0800L040N-T20	8.0	0.2	25.6	23.9	●	●	●	●	●	●	●	●																																																																																																																																																			
0900M020N-T20		0900M040N-T20	9.0	0.2	25.6	23.9	●	●	●	●	●	●	●	●																																																																																																																																																			
1000N020N-T20		1000N040N-T20	10.0	0.2	25.6	23.9	●	●	●	●	●	●	●	●																																																																																																																																																			

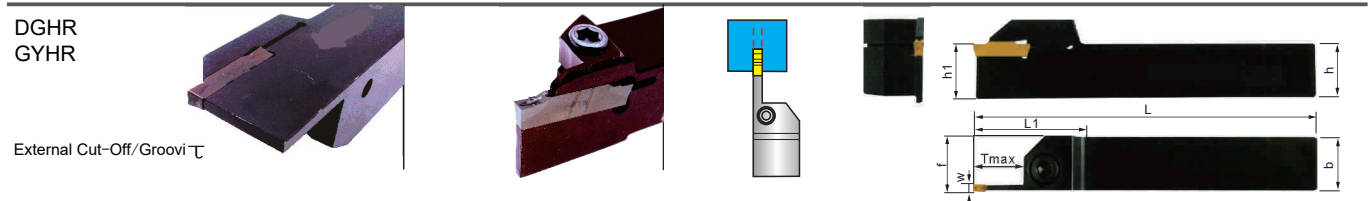

Ordering code	Dimensions							Insert	Screw	Wrench	Stock	
	W	b	h	L	h1	f	Tmax				R	L
DGHR/L 1616K2	2	16	16	125	16	16.2	16	DGM20CE	230103	230061	●	●
2020K2	2	20	20	125	20	20.2	20				●	●
2525M2	2	25	25	150	25	25.2	20				●	●
DGHR/L 1616K3	3	16	16	125	16	16.2	16	DGM30CE DGJ30CE	230103	230061	●	●
2020K3	3	20	20	125	20	20.2	20				●	●
2525M3	3	25	25	150	25	25.2	20				●	●
DGHR/L 2020K4	4	20	20	125	20	20.2	20	DGJ40CE	230107	230062	●	●
2525M4	4	25	25	150	25	25.2	20				●	●
3232P4	4	32	32	170	32	32	20				●	●
DGHR/L 2525M5	5	25	25	150	25	25.2	20	DGJ50CE	230107	230062	●	●
3232P5	5	32	32	170	32	32	20				●	●
DGHR/L 2525M6	6	25	25	150	25	25.2	20				●	●
DGHR/L 3232P6	6	32	32	170	32	32	20	DGJ60CE	230107	230062	○	○
GY2M Series Cutting Cut-Off/Grooving Toolholder												
GYHR/L 1616H2	2	16	16	100	16	16	18	GY2M0200	230103	230061	○	○
2020K2	2	20	20	125	20	20	20				○	○
2525M2	2	25	25	150	25	25	20				○	○
GYHR/L 1616H3	3	16	16	100	16	16	18	GY2M0300 GY2M0318	230103	230061	○	○
2020K3	3	20	20	125	20	20	20				○	○
2525M3	3	25	25	150	25	25	20				○	○
3232P3	3	32	32	170	32	32	20				○	○
GYHR/L 1616H4	4	16	16	100	16	16	12	GY2M0400	230107	230062	○	○
2020K4	4	20	20	125	20	20	25				○	○
2525M4	4	25	25	150	25	25	25				○	○
3232P4	4	32	32	170	32	32	25				○	○
GYHR/L 2525M5	5	25	25	150	25	25	25	GY2M0500	230107	230062	○	○
3232P5	5	32	32	170	32	32	25				○	○

WGE

Cutting Environment																																																																																											
● Stable Cutting ● General Cutting ✖ Unstable Cutting																																																																																											
Application																																																																																											
<table border="1"> <tr><td>P</td><td>Steel</td><td>●</td><td>●</td><td>●</td><td>●</td><td>●</td><td>●</td><td>●</td><td>●</td><td>●</td><td>●</td></tr> <tr><td>M</td><td>Stainless Steel</td><td>●</td><td>●</td><td>●</td><td>●</td><td>●</td><td>●</td><td>●</td><td>●</td><td>●</td><td>●</td></tr> <tr><td>K</td><td>Iron</td><td>●</td><td>●</td><td>●</td><td>●</td><td>●</td><td>●</td><td>●</td><td>●</td><td>●</td><td>●</td></tr> <tr><td>N</td><td>Aluminum/Copper/Magnesium/Zinc/Plastic/Wood</td><td>●</td><td>●</td><td>●</td><td>●</td><td>●</td><td>●</td><td>●</td><td>●</td><td>●</td><td>●</td></tr> <tr><td>S</td><td>Carbide/Powder Metallurgy</td><td>●</td><td>●</td><td>●</td><td>●</td><td>●</td><td>●</td><td>●</td><td>●</td><td>●</td><td>●</td></tr> <tr><td>H</td><td>Titanium/Superalloy/Carbon Fiber</td><td>●</td><td>●</td><td>●</td><td>●</td><td>●</td><td>●</td><td>●</td><td>●</td><td>●</td><td>●</td></tr> </table>												P	Steel	●	●	●	●	●	●	●	●	●	●	M	Stainless Steel	●	●	●	●	●	●	●	●	●	●	K	Iron	●	●	●	●	●	●	●	●	●	●	N	Aluminum/Copper/Magnesium/Zinc/Plastic/Wood	●	●	●	●	●	●	●	●	●	●	S	Carbide/Powder Metallurgy	●	●	●	●	●	●	●	●	●	●	H	Titanium/Superalloy/Carbon Fiber	●	●	●	●	●	●	●	●	●	●								
P	Steel	●	●	●	●	●	●	●	●	●	●																																																																																
M	Stainless Steel	●	●	●	●	●	●	●	●	●	●																																																																																
K	Iron	●	●	●	●	●	●	●	●	●	●																																																																																
N	Aluminum/Copper/Magnesium/Zinc/Plastic/Wood	●	●	●	●	●	●	●	●	●	●																																																																																
S	Carbide/Powder Metallurgy	●	●	●	●	●	●	●	●	●	●																																																																																
H	Titanium/Superalloy/Carbon Fiber	●	●	●	●	●	●	●	●	●	●																																																																																
Dimensioning	Product Image	Specification	Dimension				Application																																																																																				
W	FE	L	B	H	PCD1	PCD2	PCD3	PCD4	PCD5	PCD6	PCD7	PCD8																																																																															
<table border="1"> <tr> <th>Dimensioning</th> <th>Product Image</th> <th>Specification</th> <th>W</th> <th>FE</th> <th>L</th> <th>B</th> <th>H</th> <th>PCD1</th> <th>PCD2</th> <th>PCD3</th> <th>PCD4</th> <th>PCD5</th> <th>PCD6</th> <th>PCD7</th> <th>PCD8</th> </tr> <tr> <td>WGE 20</td> <td></td> <td>30</td> <td>2.0</td> <td>0.2</td> <td>20</td> <td>-</td> <td>4.7</td> <td>●</td> <td>●</td> <td>●</td> <td>●</td> <td>●</td> <td>●</td> <td>●</td> <td>●</td> </tr> <tr> <td>40</td> <td></td> <td>50</td> <td>3.0</td> <td>0.2</td> <td>20</td> <td>-</td> <td>5.5</td> <td>●</td> <td>●</td> <td>●</td> <td>●</td> <td>●</td> <td>●</td> <td>●</td> <td>●</td> </tr> <tr> <td>50</td> <td></td> <td></td> <td>4.0</td> <td>0.2</td> <td>25</td> <td>-</td> <td>5.7</td> <td>●</td> <td>●</td> <td>●</td> <td>●</td> <td>●</td> <td>●</td> <td>●</td> <td>●</td> </tr> <tr> <td></td> <td></td> <td></td> <td>5.0</td> <td>0.2</td> <td>25</td> <td>-</td> <td>5.9</td> <td>●</td> <td>●</td> <td>●</td> <td>●</td> <td>●</td> <td>●</td> <td>●</td> <td>●</td> </tr> </table>												Dimensioning	Product Image	Specification	W	FE	L	B	H	PCD1	PCD2	PCD3	PCD4	PCD5	PCD6	PCD7	PCD8	WGE 20		30	2.0	0.2	20	-	4.7	●	●	●	●	●	●	●	●	40		50	3.0	0.2	20	-	5.5	●	●	●	●	●	●	●	●	50			4.0	0.2	25	-	5.7	●	●	●	●	●	●	●	●				5.0	0.2	25	-	5.9	●	●	●	●	●	●	●	●
Dimensioning	Product Image	Specification	W	FE	L	B	H	PCD1	PCD2	PCD3	PCD4	PCD5	PCD6	PCD7	PCD8																																																																												
WGE 20		30	2.0	0.2	20	-	4.7	●	●	●	●	●	●	●	●																																																																												
40		50	3.0	0.2	20	-	5.5	●	●	●	●	●	●	●	●																																																																												
50			4.0	0.2	25	-	5.7	●	●	●	●	●	●	●	●																																																																												
			5.0	0.2	25	-	5.9	●	●	●	●	●	●	●	●																																																																												
<table border="1"> <tr> <th>Dimensioning</th> <th>Product Image</th> <th>Specification</th> <th>W</th> <th>FE</th> <th>L</th> <th>B</th> <th>H</th> <th>PCD1</th> <th>PCD2</th> <th>PCD3</th> <th>PCD4</th> <th>PCD5</th> <th>PCD6</th> <th>PCD7</th> <th>PCD8</th> </tr> <tr> <td>WGE 20L</td> <td></td> <td>30L</td> <td>2.0</td> <td>0.2</td> <td>20</td> <td>-</td> <td>4.7</td> <td>●</td> <td>●</td> <td>●</td> <td>●</td> <td>●</td> <td>●</td> <td>●</td> <td>●</td> </tr> <tr> <td>40L</td> <td></td> <td>50L</td> <td>3.0</td> <td>0.2</td> <td>20</td> <td>-</td> <td>5.5</td> <td>●</td> <td>●</td> <td>●</td> <td>●</td> <td>●</td> <td>●</td> <td>●</td> <td>●</td> </tr> <tr> <td>50L</td> <td></td> <td></td> <td>4.0</td> <td>0.2</td> <td>25</td> <td>-</td> <td>5.7</td> <td>●</td> <td>●</td> <td>●</td> <td>●</td> <td>●</td> <td>●</td> <td>●</td> <td>●</td> </tr> <tr> <td></td> <td></td> <td></td> <td>5.0</td> <td>0.2</td> <td>25</td> <td>-</td> <td>5.9</td> <td>●</td> <td>●</td> <td>●</td> <td>●</td> <td>●</td> <td>●</td> <td>●</td> <td>●</td> </tr> </table>												Dimensioning	Product Image	Specification	W	FE	L	B	H	PCD1	PCD2	PCD3	PCD4	PCD5	PCD6	PCD7	PCD8	WGE 20L		30L	2.0	0.2	20	-	4.7	●	●	●	●	●	●	●	●	40L		50L	3.0	0.2	20	-	5.5	●	●	●	●	●	●	●	●	50L			4.0	0.2	25	-	5.7	●	●	●	●	●	●	●	●				5.0	0.2	25	-	5.9	●	●	●	●	●	●	●	●
Dimensioning	Product Image	Specification	W	FE	L	B	H	PCD1	PCD2	PCD3	PCD4	PCD5	PCD6	PCD7	PCD8																																																																												
WGE 20L		30L	2.0	0.2	20	-	4.7	●	●	●	●	●	●	●	●																																																																												
40L		50L	3.0	0.2	20	-	5.5	●	●	●	●	●	●	●	●																																																																												
50L			4.0	0.2	25	-	5.7	●	●	●	●	●	●	●	●																																																																												
			5.0	0.2	25	-	5.9	●	●	●	●	●	●	●	●																																																																												

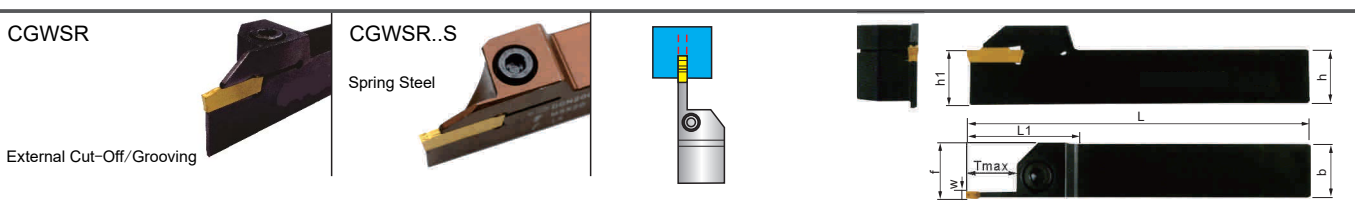

Ordering code	Dimensions							Insert	Screw	Wrench	Stock				
	W	b	h	L	h1	f	Tmax				R	L			
CGWSR/L 1616-W20-L	2	16	16	100	16	16.4	15	WGE20	230103	230061	●	●			
2020-W20-L	2	20	20	125	20	20.4	15				WGE20R/L	230107	230062	●	●
2525-W20-L	2	25	25	150	25	25.4	15				●	●			
CGWSR/L 1616-W30-L	3	16	16	100	16	16.4	16.5	WGE30	230103	230061	●	●			
2020-W30-L	3	20	20	125	20	20.4	16.5				WGE30R/L	230107	230062	●	●
2525-W30-L	3	25	25	150	25	25.4	16.5				WGT30	230107	230062	●	●
CGWSR/L 2020-W40-L	4	20	20	125	20	20.4	21	WGE40,WGE40R/L	230107	230062	●	●			
2525-W40-L	4	25	25	150	25	25.4	21				WGT40,WGR40	230107	230062	●	●
CGWSR/L 2020-W50-L	5	20	20	125	20	20.4	21	WGE50,WGE50R/L	230107	230062	●	●			
2525-W50-L	5	25	25	150	25	25.4	21				WGT50,WGR50	230107	230062	●	●
Spring Steel Shock-Proof Toolholder (Shock-Proof Effect > 4 Times Toolholder Diameter)															
T-CGWSR/L 1616-W20	2	16	16	100	16	16.4	15	WGE20	230103	230061	●	●			
2020-W20	2	20	20	125	20	20.4	15				WGE20R/L	230107	230062	●	●
2525-W20	2	25	25	150	25	25.4	15				●	●			
T-CGWSR/L 1616-W30	3	16	16	100	16	16.4	16.5	WGE30	230103	230061	●	●			
2020-W30	3	20	20	125	20	20.4	16.5				WGE30R/L	230107	230062	●	●
2525-W30	3	25	25	150	25	25.4	16.5				WGT30	230107	230062	●	●
T-CGWSR/L 2020-W40	4	20	20	125	20	20.4	21	WGE40,WGE40R/L	230107	230062	●	●			
2525-W40	4	25	25	150	25	25.4	21				WGT40,WGR40	230107	230062	●	●
T-CGWSR/L 2020-W50	5	20	20	125	20	20.4	21	WGE50,WGE50R/L	230107	230062	●	●			
2525-W50	5	25	25	150	25	25.4	21				WGT50,WGR50	230107	230062	●	●

GBA

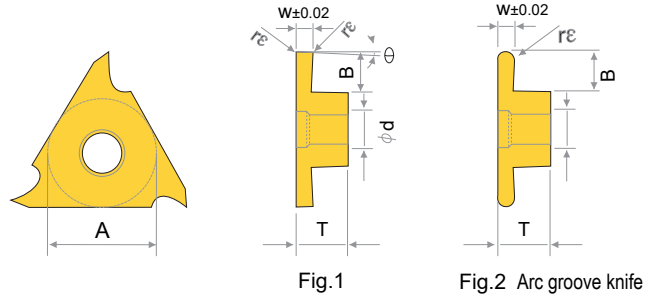

(Cutting Speed): m/min

Material	PCD1	CBN1	CBN2	PM30	N021	PMK25	PMK26	PMK30
Cutter Material	Diamond	Cast Iron	Hardened Material	Good Surface	Copper/Aluminum	Yellow	Purple	Stainless Steel
P Low-Carbon steel				150-600		60-250	70-250	100-250
M High-Carbon steel				150-350		60-150	70-150	80-150
K Hardened Steel			10-30			20-60	20-60	20-60
M Stainless Steel				200-300		50-150	50-150	70-150
K Gray Cast Iron		300-1500		100-300		130-210	150-200	150-300
K Ductile Iron		400-800		100-200		100-160	100-150	150-230
N Magnesium/Zinc/Plastic/Wood	300-1200			300-1200				
N Aluminum Alloy	300-1500			300-1500				
N Hardened Aluminum Alloy	300-800			300-800				
N Copper/Brass	300-1000			300-1000				
S Carbide/Powder Metallurgy	10-30			10-30				
H Silicon Filled Plastic Hard Fiber	400-600			400-600				
H Titanium/Superalloy/Carbon Fiber	100-200			100-200		20-50	20-50	20-60

Application	Specification	W±0.02	B	rE	A	T	φd	Fig	θ	PCD1	CBN1	CBN2	PM30	N021	PMK25	PMK26	PMK30	PMK31	
P	Steel									●	●	●	●	●	●	●	●	●	●
M	Stainless Steel									●	●	●	●	●	●	●	●	●	●
K	Iron									●	●	●	●	●	●	●	●	●	●
N	Aluminum/Copper/Magnesium/Zinc/Plastic/Wood									●	●	●	●	●	●	●	●	●	●
S	Carbide/Powder Metallurgy									●	●	●	●	●	●	●	●	●	●
H	Titanium/Superalloy/Carbon Fiber									●	●	●	●	●	●	●	●	●	●

Application	Specification	W±0.02	B	rE	A	T	φd	Fig	θ	PCD1	CBN1	CBN2	PM30	N021	PMK25	PMK26	PMK30	PMK31	
P	Steel									●	●	●	●	●	●	●	●	●	●
M	Stainless Steel									●	●	●	●	●	●	●	●	●	●
K	Iron									●	●	●	●	●	●	●	●	●	●
N	Aluminum/Copper/Magnesium/Zinc/Plastic/Wood									●	●	●	●	●	●	●	●	●	●
S	Carbide/Powder Metallurgy									●	●	●	●	●	●	●	●	●	●
H	Titanium/Superalloy/Carbon Fiber									●	●	●	●	●	●	●	●	●	●

Application	Specification	W±0.02	B	rE	A	T	φd	Fig	θ	PCD1	CBN1	CBN2	PM30	N021	PMK25	PMK26	PMK30	PMK31
GBA43%	100-010	1.00			12.7	4.76	5.5	Fig.1	2°	●	●	●	●	●	●	●	●	●
	120-010	1.20	2.0	0.1						●	●	●	●	●	●	●	●	●
	125-010	1.25								●	●	●	●	●	●	●	●	●
	125-020	1.25								●	●	●	●	●	●	●	●	●
	140-020	1.40	2.0	0.2						●	●	●	●	●	●	●	●	●
	145-020	1.45								●	●	●	●	●	●	●	●	●
	150-010	1.50	3.5	0.1						●	●	●	●	●	●	●	●	●
	150-020	1.50	3.5	0.2						●	●	●	●	●	●	●	●	●
	170-020	1.70								●	●	●	●	●	●	●	●	●
	175-020	1.75								●	●	●	●	●	●	●	●	●
	180-020	1.80								●	●	●	●	●	●	●	●	●
	185-020	1.85	3.5	0.2	12.7	4.76	5.5	Fig.1	2°	●	●	●	●	●	●	●	●	●
	190-020	1.90								●	●	●	●	●	●	●	●	●
	195-020	1.95								●	●	●	●	●	●	●	●	●
	200-010	2.00	3.5	0.1						●	●	●	●	●	●	●	●	●
	200-020	2.00	3.5	0.2						●	●	●	●	●	●	●	●	●
	220-020	2.20								●	●	●	●	●	●	●	●	●
	225-020	2.25	3.5	0.2						●	●	●	●	●	●	●	●	●
	230-020	2.30								●	●	●	●	●	●	●	●	●
	250-010	2.50	5.0	0.1	12.7	4.76	5.5	Fig.1	2°	●	●	●	●	●	●	●	●	●
	250-030	2.50	5.0							●	●	●	●	●	●	●	●	●
	260-030	2.60	5.0	0.3						●	●	●	●	●	●	●	●	●
	265-030	2.65								●	●	●	●	●	●	●	●	●
	270-030	2.70	5.0	0.3						●	●	●	●	●	●	●	●	●
	280-030	2.80			12.7	4.76	5.5	Fig.1	2°	●	●	●	●	●	●	●	●	●
	290-030	2.90								●	●	●	●	●	●	●	●	●
	300-010	3.00	5.0	0.1						●	●	●	●	●	●	●	●	●
	300-030	3.00	5.0	0.3						●	●	●	●	●	●	●	●	●
	310-030	3.10								●	●	●	●	●	●	●	●	●
	320-030	3.20								●	●	●	●	●	●	●	●	●
	325-030	3.25	5.0	0.3	12.7	4.76	5.5	Fig.1	2°	●	●	●	●	●	●	●	●	●
	330-030	3.30								●	●	●	●	●	●	●	●	●
	340-030	3.40								●	●	●	●	●	●	●	●	●
	350-010	3.50	5.0	0.1						●	●	●	●	●	●	●	●	●
	350-030	3.50	5.0	0.3						●	●	●	●	●	●	●	●	●
	360-030	3.60								●	●	●	●	●	●	●	●	●
	370-030	3.70	5.0	0.3	12.7	4.76	5.5	Fig.1	2°	●	●	●	●	●	●	●	●	●
	380-030	3.80								●	●	●	●	●	●	●	●	●
	390-030	3.90								●	●	●	●	●	●	●	●	●
	400-010	4.00	5.0	0.1						●	●	●	●	●	●	●	●	●
	400-040	4.00	5.0	0.4						●	●	●	●	●	●	●	●	●
	410-040	4.10								●	●	●	●	●	●	●	●	●
	420-040	4.20								●	●	●	●	●	●	●	●	●
	430-040	4.30	5.0	0.4	12.7	4.76	5.5	Fig.1	2°	●	●	●	●	●	●	●	●	●
	440-040	4.40								●	●	●	●	●	●	●	●	●
	450-010	4.50	5.0	0.1						●	●	●	●	●	●	●	●	●
	450-040	4.50	5.0	0.4						●	●	●	●	●	●	●	●	●
	460-040	4.60								●	●	●	●	●	●	●	●	●
	470-040	4.70	5.0	0.4	12.7	4.76	5.5	Fig.1	2°	●	●	●	●	●	●	●	●	●
	480-040	4.80								●	●	●	●	●	●	●	●	●
	490-040	4.90								●	●	●	●	●	●	●	●	●
	500-010	5.00	5.0	0.1	12.7	5.00	5.5	Fig.1	2°	●	●	●	●	●	●	●	●	●
	500-040	5.00	5.0	0.4						●	●	●	●	●	●	●	●	●
	510-040	5.10	5.0	0.4	12.7	5.10	5.5	Fig.1	2°	●	●	●	●	●	●	●	●	●

Application	Specification	W±0.02	B	rE	A	T	φd	Fig	θ	PCD1	CBN1	CBN2	PM30	N021	PMK25	PMK26	PMK30	PMK31
GBA43%	100-R050	1.00	2.0	0.50						●	●	●	●	●	●	●	●	●
	150-R075	1.50	3.5	0.75	12.7	4.76	5.5	Fig.2	2°	●	●	●	●	●	●	●	●	●
	200-R100	2.00	3.5	1.00						●	●	●	●	●	●	●	●	●
	250-R125	2.50	4.0	1.25						●	●	●	●	●	●	●	●	●
	300-R150	3.00	4.0	1.50						●	●	●	●	●	●	●	●	●
	400-R200	4.00	5.0	2.00						●	●	●	●	●	●	●	●	●

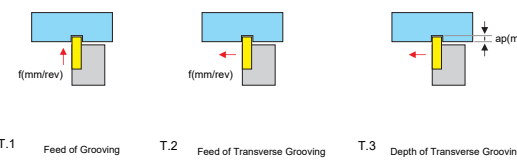

Application	Processed Material	Cutting Parameter														
		GBA43% 100-150			GBA43% 150-200			GBA43% 210-300			GBA43% 310-400			GBA43% 410-510		
		T.1	T.2	T.3	T.1	T.2	T.3	T.1	T.2	T.3	T.1	T.2	T.3	T.1	T.2	T.3
P	Steel	0.03	-	-	0.04	0.04	0.02	0.05	0.05	0.02	0.05	0.05	0.02	0.05	0.05	0.02
M	Stainless Steel	0.03	-	-	0.04	0.04	0.02	0.05	0.05	0.02	0.05	0.05	0.02	0.05	0.05	0.02
K	Iron	0.03	-	-	0.04	0.04	0.02	0.05	0.05	0.02	0.05	0.05	0.02	0.05	0.05	0.02
N	Aluminum/Copper/Magnesium/Zinc/Plastic/Wood	0.03	-	-	0.04	0.04	0.02	0.05	0.05	0.02	0.05	0.05	0.02			

External / Internal Grooving turning tool

SGBSR

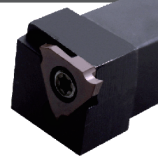

External Grooving

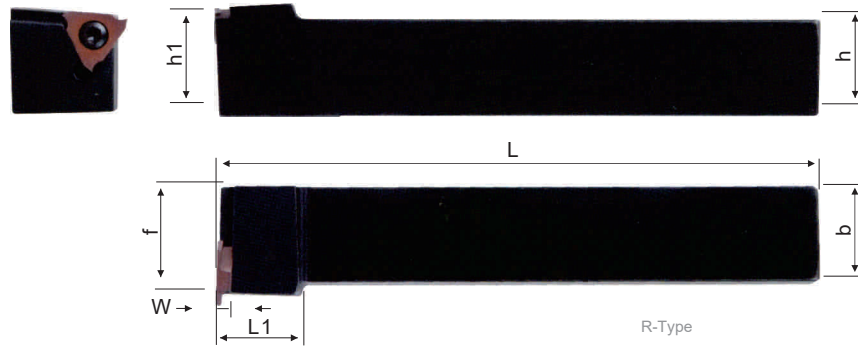
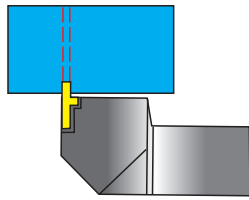

R-Type

Ordering code	Dimensions							Insert	Screw	Wrench	Stock	
	W	b	h	L	L1	h1	f				R	L
SGBSR/L 1616H32	0.5-2.5	16	16	100	22	16	20	GBA32R/L	230092	230057	•	•
2020K32	0.5-2.5	20	20	125	26	20	25				•	•
2525M32	0.5-2.5	25	25	150	26	25	32				•	•
SGBSR/L 2020K43	1.25-4.5	20	20	125	26	20	25	GBA43R/L125-450	230101	230058	•	•
2525M43	1.25-4.5	25	25	150	26	25	32				•	•

S..SGBR



External Grooving

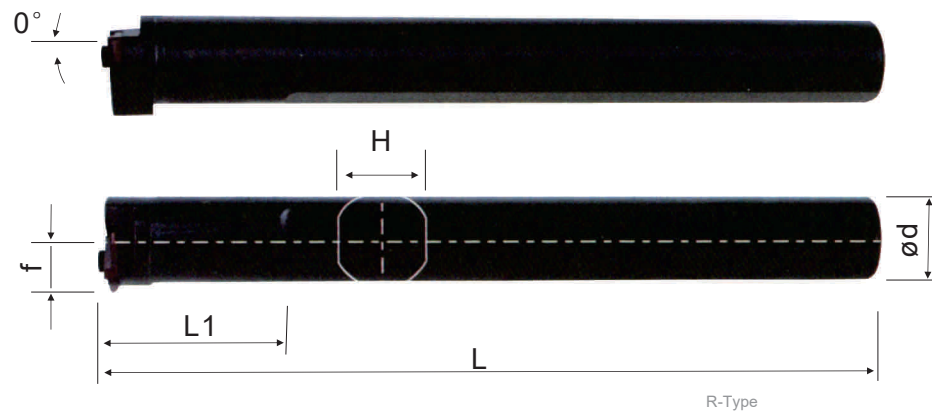
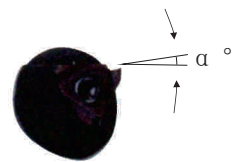
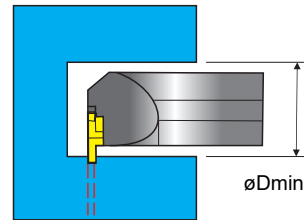

R-Type

Ordering code	Dimensions							Insert	Screw	Wrench	Stock	
	ϕD_{min}	d	f	L	L1	H	W				R	L
S16N-SGBR/L16	20	16	11	160	30	15	0.3-3	GBA32L/R 32	230091	230057	•	•
S20R-SGBR/L 32	24	20	12.8	200	40	19	0.3-3				•	•
S25S-SGBR/L 32	29	25	15.3	250	40	23	0.3-3				•	•
S32T-SGBR/L 43	40	32	21.5	300	50	30	1.5-5				•	•

MGHR

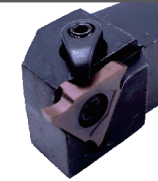

Internal Grooving Processing

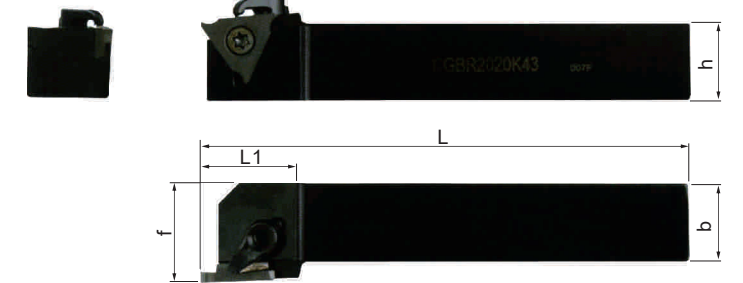
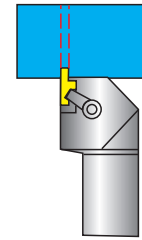

R-Type

Ordering code	Dimensions							Insert	Clamp	Screw	Wrench	Stock	
	W	b	h	L	L1	h1	f					R	L
MGHR/L 2020K3315	1.25-2.3	20	20	125	17	20	20.2	MGTR/L33125-33470	230128	230086 230114	230057 230059	•	•
2020K3323	2.3-3.3	20	20	125	17	20	20.2					•	•
2525M3315	1.25-2.3	25	25	150	17	25	25.2					•	•
2525M3323	2.3-3.3	25	25	150	17	25	25.2					•	•
2525M3333	3.3-4.7	25	25	150	17	25	25.2	MGTR/L43125-43470	230128	230101 230114	230058 230059	•	•
MGHR/L 2020K4315	1.25-2.3	20	20	125	26	20	20.2					•	•
2020K4323	2.3-3.3	20	20	125	26	20	20.2					•	•
2020K4333	3.3-4.7	20	20	125	26	20	20.2					•	•
2525M4315	1.25-2.3	25	25	150	26	25	25.2					•	•
2525M4323	2.3-3.3	25	25	150	26	25	25.2					•	•
2525M4333	3.3-4.7	25	25	150	26	25	25.2	MGTR/L44500-44600			•	•	
2525M4447	4.7-6.3	25	25	150	26	25	25.2				•	•	

GWCR

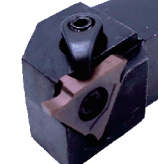

External Grooving

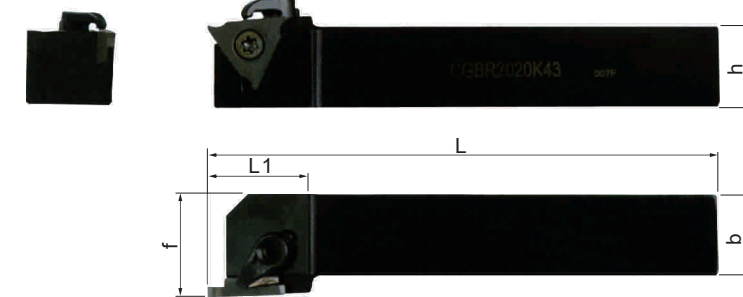
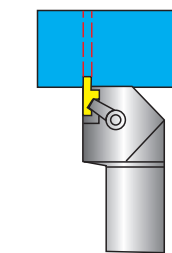

R-Type

Ordering code	Dimensions							Insert	Clamp	Screw	Wrench	Stock	
	W	b	h	L	L1	h1	f					R	L
GWC R/L 1010-3	0.33-2.80	10	10	125	17	10	10	TGAR/L3033-3280	230128	230086 230114	230057 230059	•	•
1212-3	0.33-2.80	12	12	125	17	12	12					•	•
1616-3	0.33-2.80	16	16	125	17	16	16					•	•
2020-3	0.33-2.80	20	20	125	17	20	20					•	•
2525-3	0.33-2.80	25	25	150	17	25	25					•	•
GWC R/L 2020-15	1.00-1.45	20	20	125	17	20	20	230128	230101 230114	230058 230059	•	•	
2020-25	1.50-2.30	20	20	125	17	20	20				•	•	
2020-35	2.50-4.80	20	20	125	17	20	20				•	•	
2525-15	1.00-1.45	25	25	150	17	25	25				•	•	
2525-25	1.50-2.30	25	25	150	17	25	25				•	•	
2525-35	2.50-4.80	25	25	150	17	25	25				•	•	

TGF

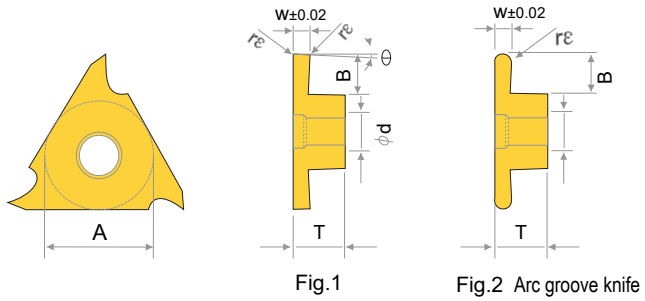

(Cutting Speed): m/min (mm)

Material	PCD1	CBN1	CBN2	PM30	N021	PMK25	PMK26	PMK30
Cutter Material	Diamond	Cast Iron	Hardened Material	Good Surface	Copper/Aluminum	Yellow	Purple	Stainless Steel
P Low-Carbon steel				150-600		60-250	70-250	100-250
M High-Carbon steel				150-350		60-150	70-150	80-150
K Hardened Steel			10-30			20-40	20-60	20-60
M Stainless Steel				200-300		50-150	50-150	70-150
K Gray Cast Iron		300-1500		100-300		130-210	150-200	150-300
N Ductile Iron		400-800		100-200		100-160	100-150	150-230
N Magnesium/Zinc/Plastic/Wood		300-1200			300-1200			
N Aluminum Alloy		300-1500			300-1500			
N Hardened Aluminum Alloy		300-800			300-800			
N Copper/Brass/Brass		300-1000			300-1000			
S Carbide/Powder Metallurgy	10-30							
H Silicon Filled Plastic Hard Fiber	400-600				400-600			
H Titanium/Superalloy/Carbon Fiber	100-200				100-200	20-50	20-50	20-60

Application	Stable Cutting	General Cutting	General Cutting(Second recommend)	Unstable Cutting
P Steel	●	●	●	●
M Stainless Steel	●	●	●	●
K Iron	●	●	●	●
N Aluminum/Copper/Magnesium/Zinc/Plastic/Wood	●	●	●	●
S Carbide/Powder Metallurgy	●	●	●	●
H Titanium/Superalloy/Carbon Fiber	●	●	●	●

Application	Stable Cutting	General Cutting	General Cutting(Second recommend)	Unstable Cutting
P Steel	●	●	●	●
M Stainless Steel	●	●	●	●
K Iron	●	●	●	●
N Aluminum/Copper/Magnesium/Zinc/Plastic/Wood	●	●	●	●
S Carbide/Powder Metallurgy	●	●	●	●
H Titanium/Superalloy/Carbon Fiber	●	●	●	●

Application	Specification	Dimension							PCD1	CBN1	CBN2	PM30	N021	PMK25	PMK26	PMK30	PMK35	PMK27	PMK30	PMK31
		W±0.02	B	rE	A	T	ϕd	Fig												
Turning	TGF32 % 030-005	0.30							●	●	●	●	●	●	●	●	●	●	●	●
	033-005	0.33	0.05						●	●	●	●	●	●	●	●	●	●	●	●
	040-005	0.40							●	●	●	●	●	●	●	●	●	●	●	●
	045-005	0.45	1.25	0.05	9.525	3.18	4.5	Fig.1	2°	●	●	●	●	●	●	●	●	●	●	●
	050-005	0.50							●	●	●	●	●	●	●	●	●	●	●	●
	050L220	0.50	2.2						●	●	●	●	●	●	●	●	●	●	●	●
	055-005	0.55							●	●	●	●	●	●	●	●	●	●	●	●
	060-005	0.60	1.25	0.05					●	●	●	●	●	●	●	●	●	●	●	●
	065-010	0.65							●	●	●	●	●	●	●	●	●	●	●	●
	070-010	0.70							●	●	●	●	●	●	●	●	●	●	●	●
	075-010	0.75							●	●	●	●	●	●	●	●	●	●	●	●
	080-010	0.80	2.05						●	●	●	●	●	●	●	●	●	●	●	●
	085-010	0.85							●	●	●	●	●	●	●	●	●	●	●	●
	090-010	0.90							●	●	●	●	●	●	●	●	●	●	●	●
	095-010	0.95							●	●	●	●	●	●	●	●	●	●	●	●
100L330	1.00	3.3						●	●	●	●	●	●	●	●	●	●	●	●	
100-010	1.00							●	●	●	●	●	●	●	●	●	●	●	●	
105-010	1.05							●	●	●	●	●	●	●	●	●	●	●	●	
110-010	1.10							●	●	●	●	●	●	●	●	●	●	●	●	
115-010	1.15							●	●	●	●	●	●	●	●	●	●	●	●	
120-010	1.20							●	●	●	●	●	●	●	●	●	●	●	●	
125-010	1.25	2.2						●	●	●	●	●	●	●	●	●	●	●	●	
130-010	1.30							●	●	●	●	●	●	●	●	●	●	●	●	
135-010	1.35							●	●	●	●	●	●	●	●	●	●	●	●	
140-010	1.40							●	●	●	●	●	●	●	●	●	●	●	●	
145-010	1.45							●	●	●	●	●	●	●	●	●	●	●	●	
150-010	1.50							●	●	●	●	●	●	●	●	●	●	●	●	
150L380	1.50	3.8						●	●	●	●	●	●	●	●	●	●	●	●	
155-010	1.55	2.4						●	●	●	●	●	●	●	●	●	●	●	●	
160-015	1.60							●	●	●	●	●	●	●	●	●	●	●	●	
165-015	1.65	2.4	0.15					●	●	●	●	●	●	●	●	●	●	●	●	
170-015	1.70							●	●	●	●	●	●	●	●	●	●	●	●	
175-010	1.75	2.4	0.1					●	●	●	●	●	●	●	●	●	●	●	●	
175-015	1.75							●	●	●	●	●	●	●	●	●	●	●	●	
180-015	1.80	2.4						●	●	●	●	●	●	●	●	●	●	●	●	
185-015	1.85							●	●	●	●	●	●	●	●	●	●	●	●	
190-015	1.90							●	●	●	●	●	●	●	●	●	●	●	●	
195-015	1.95	2.7						●	●	●	●	●	●	●	●	●	●	●	●	
200-010	2.00	2.7	0.1					●	●	●	●	●	●	●	●	●	●	●	●	
200-015	2.00	2.7	0.15					●	●	●	●	●	●	●	●	●	●	●	●	
200L400	2.00	4.0	0.1					●	●	●	●	●	●	●	●	●	●	●	●	
210-015	2.10							●	●	●	●	●	●	●	●	●	●	●	●	
215-015	2.15							●	●	●	●	●	●	●	●	●	●	●	●	
220-015	2.20							●	●	●	●	●	●	●	●	●	●	●	●	
225-015	2.25	2.7	0.15					●	●	●	●	●	●	●	●	●	●	●	●	
230-015	2.30							●	●	●	●	●	●	●	●	●	●	●	●	
240-015	2.40							●	●	●	●	●	●	●	●	●	●	●	●	
250-010	2.50	3.0	0.1					●	●	●	●	●	●	●	●	●	●	●	●	
250-015	2.50	3.0	0.15					●	●	●	●	●	●	●	●	●	●	●	●	
250L400	2.50	4.0	0.1					●	●	●	●	●	●	●	●	●	●	●	●	
260-015	2.60							●	●	●	●	●	●	●	●	●	●	●	●	
265-015	2.65							●	●	●	●	●	●	●	●	●	●	●	●	
270-015	2.70							●	●	●	●	●	●	●	●	●	●	●	●	
280-015	2.80	3.0	0.15					●	●	●	●	●	●	●	●	●	●	●	●	
290-015	2.90							●	●	●	●	●	●	●	●	●	●	●	●	
300-020	3.00							●	●	●	●	●	●	●	●	●	●	●	●	
320-020	3.20							●	●	●	●	●	●	●	●	●	●	●	●	

Application	Specification	Dimension							PCD1	CBN1	CBN2	PM30	N021	PMK25	PMK26	PMK30	PMK35	PMK27	PMK30	PMK31	
		W±0.02	B	rE	A	T	ϕd	Fig													
Turning	TGF32 % 100-R050	1.00	2.2	0.50					●	●	●	●	●	●	●	●	●	●	●	●	
	150-R075	1.50	2.2	0.75					●	●	●	●	●	●	●	●	●	●	●	●	
	200-R100	2.00	2.7	1.00	9.525	3.18	4.5	Fig.2	2°	●	●	●	●	●	●	●	●	●	●	●	
	250-R125	2.50	3.0	1.25					●	●	●	●	●	●	●	●	●	●	●	●	●
	300-R150	3.00	3.2	1.50					●	●	●	●	●	●	●	●	●	●	●	●	●

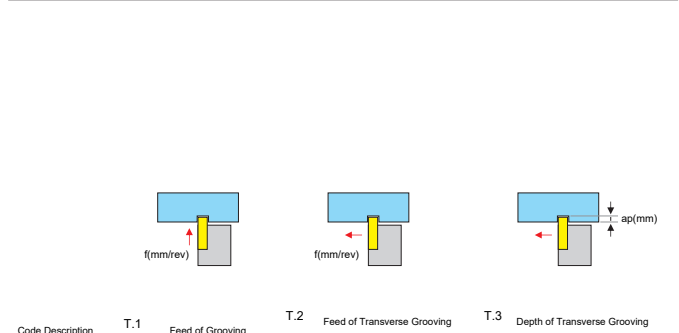

Application	Processed Material	Cutting Parameter														
		TGF32%/033-055			TGF32%/055-095			TGF32%/100-145			TGF32%/150-250			TGF32%/255-320		
		T.1	T.2</													

External Cut-off / Grooving turning tool

CTGFR

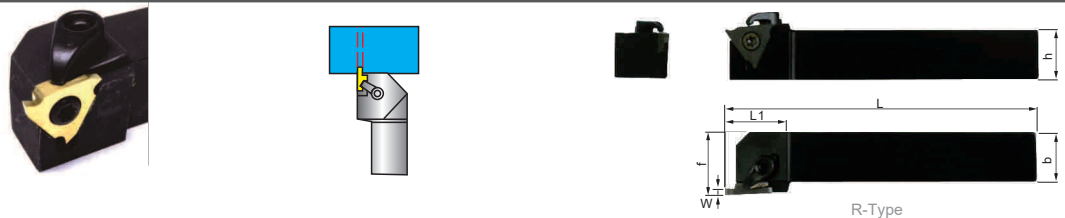

External Grooving

Ordering code	Dimensions							Insert	Clamp	Screw	Wrench	Stock	
	W	b	h	L	L1	h1	f					R	L
CTGFR/L1010F-16	0.33-2.5	10	10	80	18.5	10	12	TGF32R/L	230128	230089 230114	230057 230059	•	•
1212H-16	0.33-2.5	12	12	100	18.5	12	16					•	•
1616H-16	0.33-2.5	16	16	100	18.5	16	20					•	•
2020K-16	0.33-2.5	20	20	125	20	20	25					•	•
2525M-16	0.33-2.5	25	25	150	20	25	32					•	•
Unbiased Head (for Automatic Lathe Back)													
CTGFR/L0808H-16F	0.33-2.5	8	8	100	18.5	8	8	TGF32R/L	230128	230089 230114	230057 230059	•	•
1010K-16F	0.33-2.5	10	10	125	18.5	10	10					•	•
1212K-16F	0.33-2.5	12	12	125	18.5	12	12					•	•
1212M-16F	0.33-2.5	12	12	150	18.5	12	12					•	•
1616K-16F	0.33-2.5	16	16	150	18.5	16	16					•	•

CTGFSR

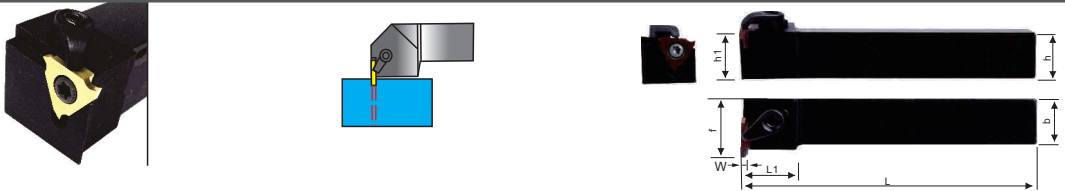

External Grooving

Ordering code	Dimensions							Insert	Clamp	Screw	Wrench	Stock	
	W	b	h	L	L1	h1	f					R	L
CTGFSR/L1616H-16	0.33-2.5	16	16	100	18.5	16	20	TGF32R/L	230128	230089 230114	230057 230059	•	•
2020K-16	0.33-2.5	20	20	125	20	20	25					•	•
2525M-16	0.33-2.5	25	25	150	20	25	32					•	•

GTTR

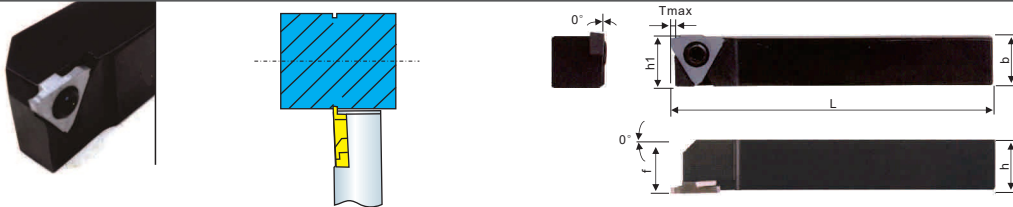

External Grooving

Ordering code	Dimensions							Insert	Screw	Wrench	Stock	
	W	b	h	L	L1	h1	f				R	L
GTTR/L 08F00	0.33-3.0	8	8	80	3	8	8	GTM.32R/L..	230092	230057	•	•
10F00	0.33-3.0	10	10	80	3	10	10				•	•
12F00	0.33-3.0	12	12	100	3	12	12				•	•
16F00	0.33-3.0	16	16	100	3	16	16				•	•
20F00	0.33-3.0	20	20	120	3	20	20				•	•
25F00	0.33-3.0	25	25	150	3	25	25				•	•

JSTGR

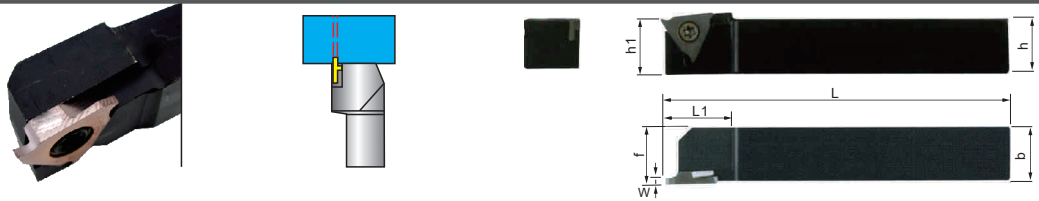

External Grooving

Ordering code	Dimensions							Insert	Screw	Wrench	Stock	
	W	b	h	L	L1	h1	f				R	L
JSTGR/L 1010K3	0.33-3.0	10	10	125	18.5	10	10	JTGR/L3	230089	230057	•	•
1212K3	0.33-3.0	12	12	125	18.5	12	12				•	•
1616K3	0.33-3.0	16	16	125	18.5	16	16				•	•

PENTA

Application	Dimensioning	Specification	Dimension							Application	Dimensioning	Specification	Dimension									
			W	ℓE	L	B	H	θ	PCD1				CBN1	CBN2	PM30	PM30	NO21	P140	P150	PM540	PM530	
Grinding groove (finishing)		PENTA24N 050P005	0.50	0.05	2.0	-	-	-	-		PENTA24N 050J	0.5	0.05	2.0	-	-	-	-	-	•	•	
		075P005	0.75	0.05	3.0	-	-	-	-			1.0	0.10	2.5	-	-	-	-	-	-	•	•
		100P005	1.00	0.05	4.0	-	-	-	-			1.50	0.10	6.0	-	-	-	-	-	-	•	•
		120P005	1.20	0.05	4.0	-	-	-	-			1.80	0.05	4.0	-	-	-	-	-	-	•	•
		150P005	1.50	0.05	4.0	-	-	-	-			2.00	0.05	4.0	-	-	-	-	-	-	•	•
		185P005	1.85	0.05	4.0	-	-	-	-			2.30	0.05	4.5	-	-	-	-	-	-	•	•
		200P005	2.00	0.05	4.0	-	-	-	-			2.50	0.05	4.5	-	-	-	-	-	-	•	•
		230P005	2.30	0.05	4.5	-	-	-	-			2.70	0.05	4.5	-	-	-	-	-	-	•	•
		250P005	2.50	0.05	4.5	-	-	-	-			3.00	0.05	4.5	-	-	-	-	-	-	•	•
		300P005	3.00	0.05	4.5	-	-	-	-													•
With chip breaker (roughing)		PENTA24N 050J	1.00	0.10	2.5	-	-	-		PENTA24N 050J	1.00	0.10	2.5	-	-	-	-	-	-	•	•	
		150J	1.50	0.10	6.0	-	-	-			2.00	0.10	6.0	-	-	-	-	-	•	•		
		200J	2.00	0.10	6.0	-	-	-			2.50	0.20	6.0	-	-	-	-	-	-	•	•	
		250J	2.50	0.20	6.0	-	-	-			3.00	0.20	6.0	-	-	-	-	-	-	•	•	
		300J	3.00	0.20	6.0	-	-	-													•	•

PCHR

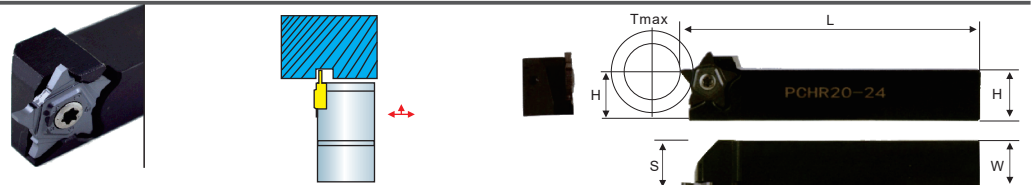

External Grooving

Ordering code	Dimensions					Insert	Screw	Wrench	Stock	
	b	h	L	h1	f				R	L
PCHR/L 16-24	16	16	100	26	16.6	PENTA24N239J015	230097	230058	•	•
16-20	20	20	125	26	20.6				•	•
16-25	25	25	150	26	25.5				•	•

FVC 1604

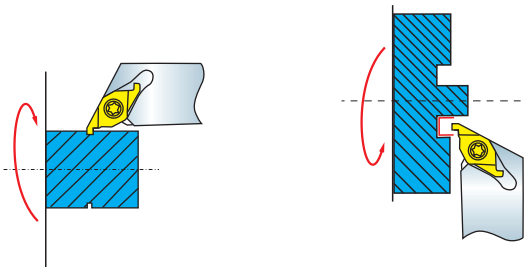

Machining of outer circular groove

End face grooving

Application	Dimensioning	Specification	Dimension							Application	Dimensioning	Specification	Dimension								
			W	ℓE	L	B	H	θ	PCD1				CBN1	CBN2	PM30	PM30	NO21	P140	P150	PM540	PM530
End face grooving		FVC1604R 100	1.0	0.05	-	-	-	-		FVC1604R 100	1.0	0.05	-	-	-	-	-	-	-	•	•
		150	1.5	0.1	-	-	-	-			2.0	0.1	2.2	16	15.7	7°	•	•			
		200	2.0	0.1	-	-	-	-			2.5	0.2	-	-	-	-	-	-	•	•	
		250	2.5	0.2	-	-	-	-			3.0	0.2	-	-	-	-	-	-	•	•	
		300	3.0	0.2	-	-	-	-												•	•

SFVCR



External Grooving

Ordering code	Dimensions					Insert	Screw	Wrench	Stock	
	b	h	L	h1	f				R	L
SFVCR/L 2020K16	20	20	125	20	25	FVC1604..	230092	230057	•	•
2525M16	25	25	150	25	32				•	•

Grooving / Cut-off Machining

End Face Grooving Turning System

Cutting Environment										Cutting Environment											
● Stable Cutting										● Stable Cutting											
● General Cutting										● General Cutting											
✖ Unstable Cutting										✖ Unstable Cutting											
P	Steel										P	Steel									
M	Stainless Steel										M	Stainless Steel									
K	Iron										K	Iron									
N	Aluminum/Copper/Magnesium/Zinc/Plastic/Wood										N	Aluminum/Copper/Magnesium/Zinc/Plastic/Wood									
S	Carbide/Powder Metallurgy										S	Carbide/Powder Metallurgy									
H	Titanium/Superalloy/Carbon Fiber										H	Titanium/Superalloy/Carbon Fiber									

Application	Dimensioning	Product Image	Specification	Dimension						Application															
				W	B	A	L	H	∅d	PCD1	CBN1	CBN2	PM30	PM30	PM30	N021	N021	N021	PM340	PM340	PM340	PM340	PM340	PM340	
Grooving			6GR 100	1.0	1.5					●	●	●	●	●	●	●	●	●	●	●	●	●	●	●	●
			150	1.5	1.5	5.56	6.44	2.34	2.3	●	●	●	●	●	●	●	●	●	●	●	●	●	●	●	●
			200	2.0	1.5					●	●	●	●	●	●	●	●	●	●	●	●	●	●	●	●
Grooving			7GR 100	1.0	1.5					●	●	●	●	●	●	●	●	●	●	●	●	●	●	●	
			150	1.5	1.5	5.56	7.36	3.08	2.58	●	●	●	●	●	●	●	●	●	●	●	●	●	●	●	●
			200	2.0	1.5					●	●	●	●	●	●	●	●	●	●	●	●	●	●	●	●
Grooving			8GR 100	1.0	1.5					●	●	●	●	●	●	●	●	●	●	●	●	●	●	●	
			150	1.5	2.0					●	●	●	●	●	●	●	●	●	●	●	●	●	●	●	●
			200	2.0	2.0	5.56	10.2	3.87	2.58	●	●	●	●	●	●	●	●	●	●	●	●	●	●	●	●
Grooving			9GR 100	1.0	1.5					●	●	●	●	●	●	●	●	●	●	●	●	●	●	●	
			150	1.5	2.0					●	●	●	●	●	●	●	●	●	●	●	●	●	●	●	●
			200	2.0	3.0	6.35	13.0	4.66	2.86	●	●	●	●	●	●	●	●	●	●	●	●	●	●	●	●
Grooving			15GR 100	1.0	1.5					●	●	●	●	●	●	●	●	●	●	●	●	●	●	●	
			150	1.5	2.0					●	●	●	●	●	●	●	●	●	●	●	●	●	●	●	●
			200	2.0	3.0	9.2	20.8	5.1	4.8	●	●	●	●	●	●	●	●	●	●	●	●	●	●	●	●

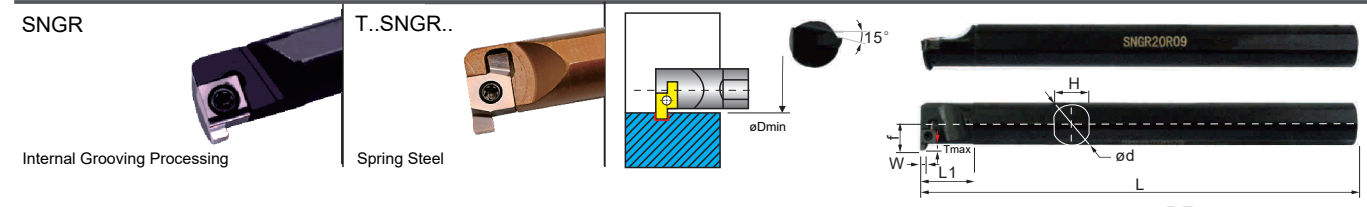

Ordering code	Dimensions							Insert	Screw	Wrench	Stock		
	Dmin	Tmax	∅d	f	L1	L	H				R	L	
SNG R/L	0806J06	10	2	8	4.7	15	100	7	6GR/L	230068	230053	●	●
	08J07	10	2	8	5.8	15	100	7	7GR/L			●	●
	10K07	12	2	10	6.8	15	125	8	7GR/L			●	●
	10K08	14	3.5	10	7.6	20	125	8	8GR/L	230074	230054	●	●
	12M08	16	3.5	12	8.6	20	150	11	8GR/L			●	●
	16Q09	20	3.5	16	11.6	20	180	14.8	9GR/L			●	●
	20R09	25	3.5	20	13.6	20	200	18.4	9GR/L			●	●
Spring Steel Shock-Proof Toolholder (Shock-Proof Effect > 4 Times Toolholder Diameter)													
T-SNG R/L	0806J06	10	2	8	4.7	15	100	7	6GR/L	230068	230053	●	●
	08J07	10	2	8	5.8	15	100	7	7GR/L			●	●
	10K07	12	2	10	6.8	15	125	8	7GR/L			●	●
	10K08	14	3.5	10	7.6	20	125	8	8GR/L	230074	230054	●	●
	12M08	16	3.5	12	8.6	20	150	11	8GR/L			●	●
	16N08	20	3.5	16	11.6	20	160	14.8	9GR/L			●	●
	12M09	16	3.5	12	8.6	20	150	11	9GR/L			●	●
	16N09	20	3.5	16	11.6	20	160	14.8	9GR/L			●	●
	20Q09	25	3.5	20	13.6	20	180	18.4	9GR/L			●	●

STFPR

CBSNR

C..Q.DR

SMFR

SMVR

SGIEFR

SGIVFR

T-SGIVFR

MFHR

MGAH..R

MGFHRR

MGAH..L

MGFHLL

MGHH..R

MGFHRL

FGHH..R

QF..L

SEGEI

SMFL

MGHH..L

MGFHRL

FGHH..L

QF..R

SSACN

SSACN

MGFV..R

MGFVR

FGVH..R

MGFV..L

MGFVL

FGVH..L

MGIVR

T-MGIVR

KIGMR

TTIR

C-QE..R

S-SGBR

SIGER

T-SIGER

SNGR

T-SNGR

S-KTGR

T-KTGR

End Face / Internal Grooving Tool

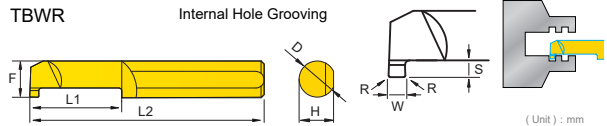

Model	W	S	L1	R	F	D	L2	H	Stock	Processing Diameter
TBWR05100R005-D4	0.5	1.0	10	0.05	3.8	D4	50	3.7	○	4mm
TBWR08100R005-D4	0.8	1.0	10	0.05	3.8	D4	50	3.7	○	4mm
TBWR10100R005-D4	1.0	1.5	10	0.05	3.8	D4	50	3.7	○	4mm
TBWR15100R005-D4	1.5	1.5	10	0.05	3.8	D4	50	3.7	○	4mm
TBWR10100R010-D5	1.0	1.5	10	0.1	4.8	D5	50	4.7	○	5mm
TBWR12100R010-D5	1.2	1.5	10	0.1	4.8	D5	50	4.7	○	5mm
TBWR15100R010-D5	1.5	2.0	10	0.1	4.8	D5	50	4.7	○	5mm
TBWR20100R010-D5	2.0	2.0	10	0.1	4.8	D5	50	4.7	○	5mm
TBWR10120R015-D6	1.0	2.0	12	0.15	5.8	D6	50	5.7	○	6mm
TBWR15120R015-D6	1.5	2.0	12	0.15	5.8	D6	50	5.7	○	6mm
TBWR20120R015-D6	2.0	2.0	12	0.15	5.8	D6	50	5.7	○	6mm
TBWR25160R015-D6	2.5	2.5	16	0.15	5.8	D6	50	5.7	○	6mm
TBWR15160R015-D8	1.5	2.0	16	0.15	7.8	D8	50	7.7	○	8mm
TBWR20160R015-D8	2.0	3.0	16	0.15	7.8	D8	50	7.7	○	8mm
TBWR25160R015-D8	2.5	3.0	16	0.15	7.8	D8	50	7.7	○	8mm

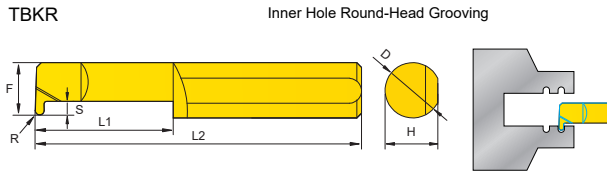

Model	F	S	L1	R	D	L2	H	Stock	Processing Diameter
TBKR40100R050-D4	3.8	1.0	10	0.5	D4	50	3.7	○	4mm
TBKR40100R075-D4	3.8	1.0	10	0.75	D4	50	3.7	○	4mm
TBKR60150R050-D6	5.8	1.5	15	0.5	D6	50	5.7	○	6mm
TBKR60150R075-D6	5.8	1.5	15	0.75	D6	50	5.7	○	6mm
TBKR60150R100-D6	5.8	1.5	15	1.0	D6	50	5.7	○	6mm

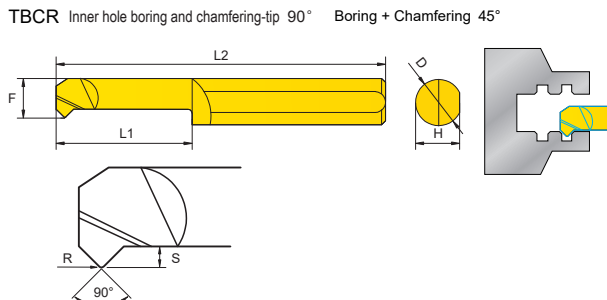

Model	F	L1	S	R	D	L2	H	Stock
TBCR30100R020-D4	2.8	10	0.5	0.2	D4	50	3.7	○
TBCR40150R020-D4	3.7	15	0.8	0.2	D4	50	3.7	○
TBCR50150R020-D5	4.7	15	1.2	0.2	D5	50	4.7	○
TBCR60150R020-D6	5.7	15	1.5	0.2	D6	50	5.7	○

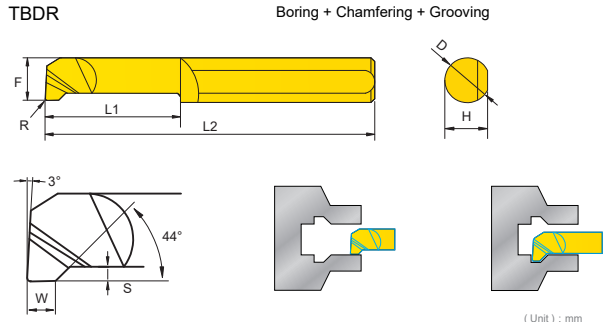

Model	F	L1	S	R	D	L2	H	W	Stock	Processing Diameter
TBDR40100R020-D4	3.8	10.0	0.8	0.2	D4	50	3.7	1.5	○	4mm
TBDR50150R020-D5	4.8	15.0	1.2	0.2	D5	50	4.7	1.5	○	5mm
TBDR60150R020-D6	5.8	15.0	1.4	0.2	D6	50	5.7	1.5	○	6mm

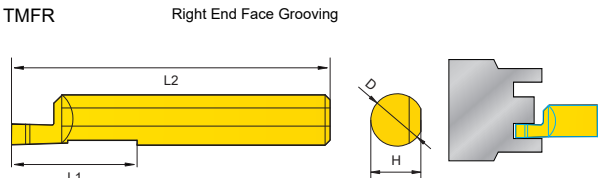

Model	F	L1	T	W	R	D	L2	H	Stock	Processing Diameter
TMFR60150W0.75-D6	2.95	15	1.5	0.75	0.1	D6	50	5.7	○	8.0
TMFR60150W1.0-D6	2.95	15	2.0	1.0	0.1	D6	50	5.7	○	8.0
TMFR60200W2.0-D8	3.95	20	4.0	2.0	0.2	D8	50	7.7	○	10.0
TMFR60200W2.5-D8	3.95	20	5.0	2.5	0.2	D8	50	7.7	○	10.0
TMFR60200W3.0-D8	3.95	20	6.0	3.0	0.2	D8	50	7.7	○	10.0

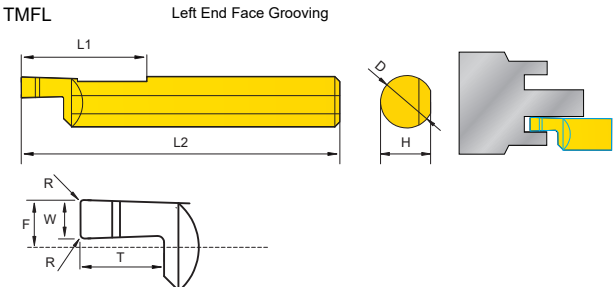

Model	F	L1	T	W	R	D	L2	H	Stock	Processing Diameter
TMFL60150W0.75-D6	2.95	15	1.5	0.75	0.1	D6	50	5.7	○	8.0
TMFL60150W1.0-D6	2.95	15	2.0	1.0	0.1	D6	50	5.7	○	8.0
TMFL60200W2.0-D8	3.95	20	4.0	2.0	0.2	D8	50	7.7	○	10.0
TMFL60200W2.5-D8	3.95	20	5.0	2.5	0.2	D8	50	7.7	○	10.0
TMFL60200W3.0-D8	3.95	20	6.0	3.0	0.2	D8	50	7.7	○	10.0

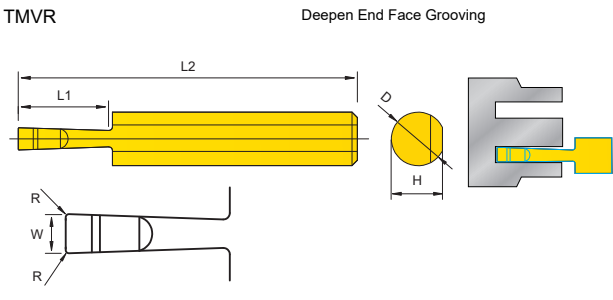

Model	L1	W	R	D	L2	H	Stock	Processing Diameter
TMVR10150W2.0-D10	15	2.0	0.2	D10	50	9	○	15
TMVR10150W3.0-D10	15	3.0	0.2	D10	50	9	○	15
TMVR10150W4.0-D10	15	4.0	0.2	D10	50	9	○	15

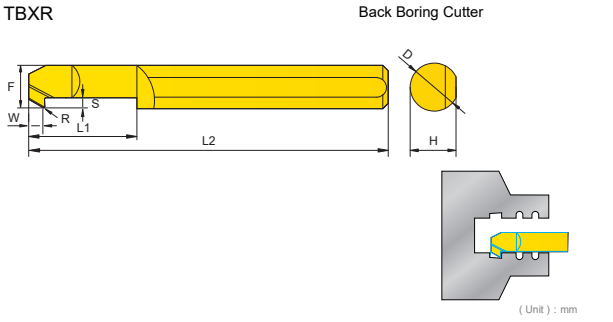

Model	F	W	S	L1	R	D	L2	H	Stock	Processing Diameter
TBXR40100R010-D4	3.8	1.5	1.0	10	0.1	D4	50	3.7	○	4mm
TBXR50150R015-D5	4.8	2.0	1.5	15	0.15	D5	50	4.7	○	5mm
TBXR60200R020-D6	5.8	2.0	2.0	20	0.2	D6	50	5.7	○	6mm

GER

Application	Dimensioning	Product Image	Specification	Dimension							PCD1	CBN1	CBN2	PM30	N021	P140	P130	P140	PMS30	PMS40	PMS50				
				W	rc	B	A	L	∅d																
End Face Grooving			GER 100DM06-D	1.0	0.05	2.5																			
			150DM10-D	1.5	0.1	2.8																			
			200DM10-D	2.0	0.1	3.5	6.8	16.4	3.4																
			250DM15-D	2.5	0.2	4.5																			
End Face Grooving			GER 150DM10R075-E	1.5	0.75	3.6																			
			200DM10R100-E	2.0	1.0	4.8																			
			250DM15R125-E	2.5	1.25	6.0	9.54	21.7	4.4																
			300DM15R150-E	3.0	1.5	6.5																			
End Face Grooving			GER 150DM10R075-E	1.5	0.75	3.6																			
			200DM10R100-E	2.0	1.0	4.8																			
			250DM15R125-E	2.5	1.25	6.0	9.54	21.7	4.4																
			300DM15R150-E	3.0	1.5	6.5																			

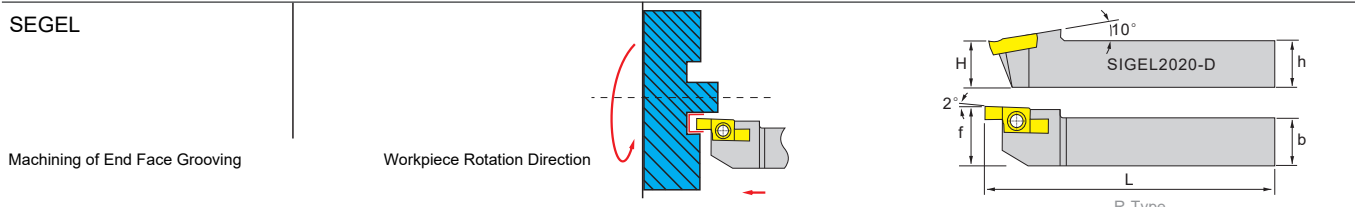

Ordering code	Dimensions						Insert	Screw	Wrench	Stock	
	∅Dmin	h	f	b	H	L				R	L
SEGEL 1010H-D	6.0	10	10	10	10	100	GER..D	230080	230056	○	●
1212H-D	6.0	12	12	12	12	100				○	●
1616K-D	6.0	16	16	16	16	125				○	●
2020K-D	6.0	20	20	20	20	125				○	●
2525M-D	6.0	25	25	25	25	150				○	●
SEGEL 1616H-E	10.0	16	16	16	16	100	GER..E	230092	230057	○	●
2020K-E	10.0	20	20	20	20	125				○	●
2525M-E	10.0	25	25	25	25	150				○	●
3232M-E	10.0	32	32	32	32	150				○	●

Application	Dimensioning	Product Image	Specification	Dimension							PCD1	CBN1	CBN2	PM30	N021	P140	P130	P140	PMS30	PMS40	PMS50			
				W	rc	B	A	L	∅d															
End Face Grooving			GEL 150DM10-E	1.5	0.1	3.6																		
			200DM10-E	2.0	0.1	4.8																		
			250DM15-E	2.5	0.2	6.0	9.54	21.7	4.4															
			300DM15-E	3.0	0.2	6.5																		
End Face Grooving			GEL 150DM10R075-E	1.5	0.75	3.6																		
			200DM10R100-E	2.0	1.0	4.8																		
			250DM15R125-E	2.5	1.25	6.0	9.54	21.7	4.4															
			300DM15R150-E	3.0	1.5	6.5																		

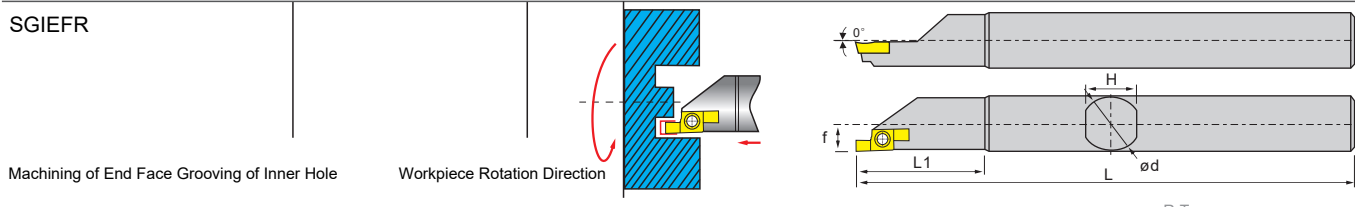

Ordering code	Dimensions						Insert	Screw	Wrench	Stock	
	∅Dmin	∅d	f	L1	L	H				R	L
SGIEFR 0020K-E	10	20	10.3	30	125	19	GEL..DM..E	230092	230057	○	●
0025M-E	10	25	12.8	30	150	24				○	●

End Face Grooving Tool

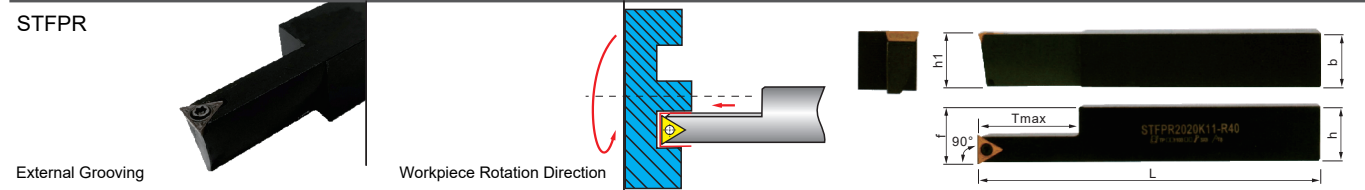

STFPR External Grooving Workpiece Rotation Direction

Ordering code	Dimensions							Insert	Screw	Wrench	Stock		
	b=h1	h	L	Dmin	Dmax	Tmax	f				R	L	
TPA0920R/L	33-20/80	20	20	125	20	80	33	21	TP..0902..	230074	230054	•	•
	35-40/160	20	20	125	40	160	35	21				•	•
	37-70/800	20	20	125	70	800	37	21				•	•
TPA0925R/L	33-20/80	25	25	150	20	80	33	26	TP..1103..	230078	230056	•	•
	35-40/160	25	25	150	40	160	35	26				•	•
	37-70/800	25	25	150	70	800	37	26				•	•
TPA1120R/L	33-20/80	20	20	125	20	80	33	21	TP..1103..	230078	230056	•	•
	38-40/160	20	20	125	40	160	38	21				•	•
	40-70/800	20	20	125	70	800	40	21				•	•
TPA1125R/L	33-20/80	25	25	150	20	80	33	26	TP..1103..	230078	230056	•	•
	38-40/160	25	25	150	40	160	38	26				•	•
	40-70/800	25	25	150	70	800	40	26				•	•

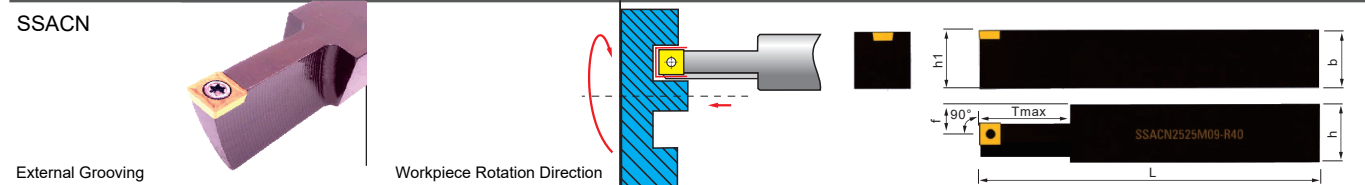

SSACN External Grooving Workpiece Rotation Direction

Ordering code	Dimensions							Insert	Screw	Wrench	Stock	
	b=h1	h	L	Dmin	Dmax	Tmax	f				R	L
SSACN 2020K09-R35	20	20	125	80	500	35	10	SC..09T3..	230092	230057	•	•
2525M09-R40	25	25	150	80	500	40	12.5				•	•

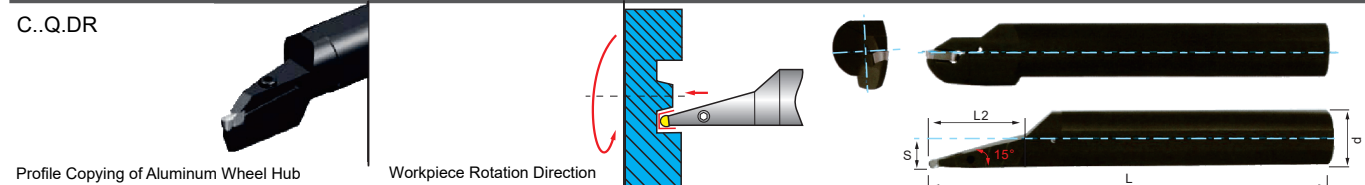

C..Q.DR Profile Copying of Aluminum Wheel Hub Workpiece Rotation Direction

Ordering code	Dimensions					Insert	Screw	Wrench	Stock	
	øDmin	ød	S	L1	L2				R	L
C40T-QLDR/L65-15A	160	40	21	300	65	ZRLD08-LH	230107	230062	•	•
C40T-QLDR/L80-15A	160	40	21	300	80				•	•
C50U-QLDR/L80-15A	160	50	26	350	80				•	•
C40T-QKDR/L60-15A	160	40	21	300	60				•	•
C40T-QKDR/L75-15A	160	40	21	300	75				•	•
C50U-QKDR/L75-15A	160	50	26	350	75	ZRKD06-LH	230107	230062	•	•

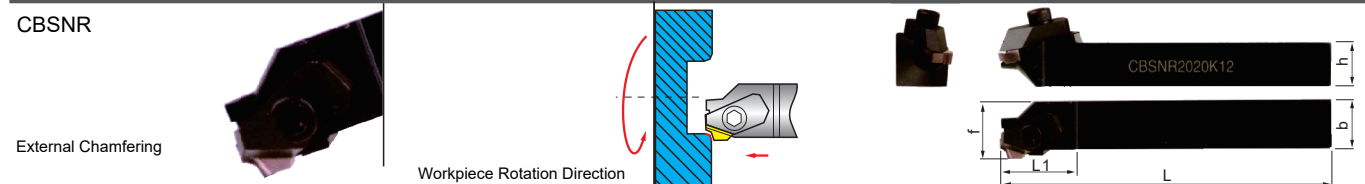

CBSNR External Chamfering Workpiece Rotation Direction

Ordering code	Dimensions					Insert	Clamp	Screw	Wrench	Stock	
	h	b	L	L1	f					R	L
CBSNR/L 2020K12	20	20	125	32	20	SNMF1204.	230125	230107	230062	•	•
2525M12	25	25	150	32	25					•	•

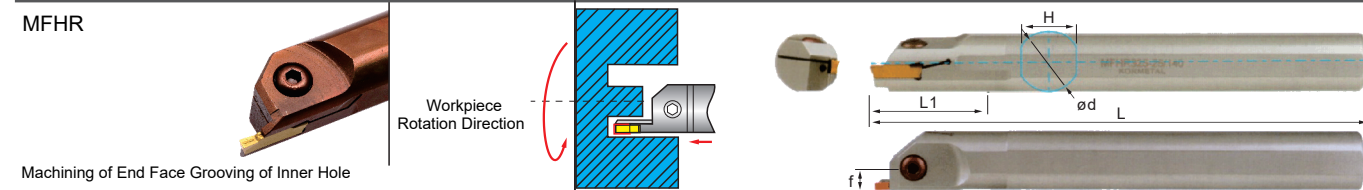

MFHR Machining of End Face Grooving of Inner Hole Workpiece Rotation Direction

Ordering code	Dimensions							Screw	Wrench	Insert	Stock		
	øDmin	ød	f	L	H	Dmin	Dmax				R	L	
MFH216R/L	06-20/140	6	16	8.3	160	14.8	20	140	230092	230060	•	•	
	08-20/140	8	16	8.3	160	14.8	20	140			•	•	
MFH220R/L	06-25/140	6	20	10.3	180	18.4	26	140	230101	230061	•	•	
	08-25/140	8	20	10.3	180	18.4	26	140			•	•	
MFH225R/L	06-25/140	6	25	12.8	200	23.4	28	140	230102	230061	•	•	
	08-25/140	8	25	12.8	200	23.4	28	140			•	•	
MFH316R/L	06-20/140	6	16	8.3	160	14.8	20	140	230092	230060	•	•	
	08-20/140	8	16	8.3	160	14.8	20	140			•	•	
MFH320R/L	06-25/140	6	20	10.3	180	18.4	26	140	230101	230061	•	•	
	08-25/140	8	20	10.3	180	18.4	26	140			•	•	
MFH325R/L	06-25/140	6	25	12.8	200	23.4	28	140	230102	230061	•	•	
	08-25/140	8	25	12.8	200	23.4	28	140			•	•	
	10-25/140	10	25	12.8	200	23.4	28	140			•	•	
MFH332R/L	06-32/200	6	32	16.3	250	30	35	200	230107	230062	•	•	
	08-32/200	8	32	16.3	250	30	35	200			•	•	
	10-32/200	10	32	16.3	250	30	35	200			•	•	
MFH420R/L	08-25/140	8	20	10.3	180	18.4	26	140	230101	230061	•	•	
	10-25/140	10	20	10.3	180	18.4	26	140			•	•	
	12-25/140	12	20	10.3	180	18.4	26	140			•	•	
MFH425R/L	08-25/140	8	25	12.8	200	23.4	28	140	230102	230061	•	•	
	10-25/140	10	25	12.8	200	23.4	28	140			•	•	
	12-25/140	12	25	12.8	200	23.4	28	140			•	•	
MFH432R/L	08-32/200	8	32	16.3	250	30	35	200	230107	230062	•	•	
	10-32/200	10	32	16.3	250	30	35	200			•	•	
	12-32/200	12	32	16.3	250	30	35	200			•	•	
MFH440R/L	08-40/500	8	40	20.3	300	38	41	500	230112	230064	•	•	
	10-40/500	10	40	20.3	300	38	41	500			•	•	
	12-40/500	12	40	20.3	300	38	41	500			•	•	
MFH540R/L	15-40/500	15	40	20.3	300	38	41	500	230112	230064	MGMN500..	•	•

VC 1604

Application	Dimensioning	Specification	Dimension							PCD1	PCD2	PCD3	PCD4	PCD5	PCD6	
			W	T	B	H	ø	ø1	ø2							
Reference		FVC1604R 100	1.0	0.05	3.5											
		150	1.5	0.1	3.5											
		200	2.0	0.1	3.5	20.6	7.4	7°								
		250	2.5	0.2	4.5											
		300	3.0	0.2	4.5											

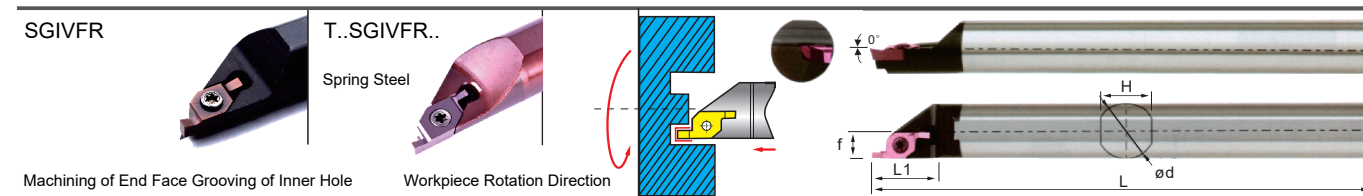

SGIVFR Machining of End Face Grooving of Inner Hole Workpiece Rotation Direction

Ordering code	Dimensions						Insert	Screw	Wrench	Stock	
	øDmin	ød	f	L1	L	H				R	L
SGIVFR 16N16	17	16	8	30	160	14.8	VC1604R..	230092	230057	•	•
20Q16	21	20	10	30	180	18.4				•	•
25R16	26	25	12.5	30	200	23.4				•	•
T-SGIVFR 10K11	11	10	5.5	12	125	9	VC1103R..	230074	230054	•	○
12M11	13	12	6.5	12	150	11				•	○
16N16	17	16	8.5	20	160	14.8	VC1604R..	230092	230057	•	○
20Q16	21	20	10.5	20	180	18.4				•	○
25R16	26	25	13	20	200	23.4				•	○

Spring Steel Shock-Proof Toolholder (Shock-Proof Effect > 4 Times Toolholder Diameter)

End Face Grooving Tool

FG

Application	Dimensioning	Product Image	Specification	Dimension					PCD1	CBN1	CBN2	P130	P140	P130	PMS40	PMS50			
				W	rE	L	B	H											
End Face Grooving			FMM 300R-03 400R-04 500R-04	3.0	0.3	15.0	2.0	3.91	-	-	-	-	-	-	-	-	-	-	
				4.0	0.4	15.0	3.0	3.96	-	-	-	-	-	-	-	-	-	-	-
				5.0	0.4	15.0	4.0	4.42	-	-	-	-	-	-	-	-	-	-	-

Application	Dimensioning	Product Image	Specification	Dimension					PCD1	CBN1	CBN2	P130	P140	P130	PMS40	PMS50			
				W	rE	L	B	H											
End Face Grooving			FGD 300R-03 400R-04 500R-04	3.0	0.3	15.0	2.0	4.0	-	-	-	-	-	-	-	-	-	-	
				4.0	0.4	15.0	3.0	4.5	-	-	-	-	-	-	-	-	-	-	-
				5.0	0.4	15.0	4.0	5.0	-	-	-	-	-	-	-	-	-	-	-
End Face Grooving			FGM 300R-03 400R-04 500R-04	3.0	0.3	15.0	2.0	4.0	-	-	-	-	-	-	-	-	-	-	
				4.0	0.4	15.0	3.0	4.5	-	-	-	-	-	-	-	-	-	-	-
				5.0	0.4	15.0	4.0	5.0	-	-	-	-	-	-	-	-	-	-	-

FGHH..R..

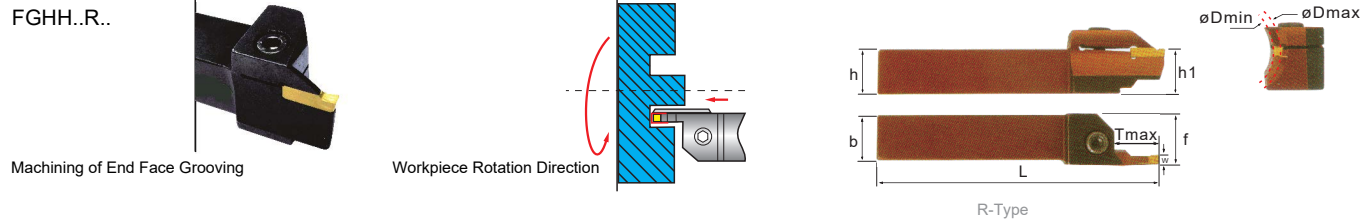

FGVH..R..

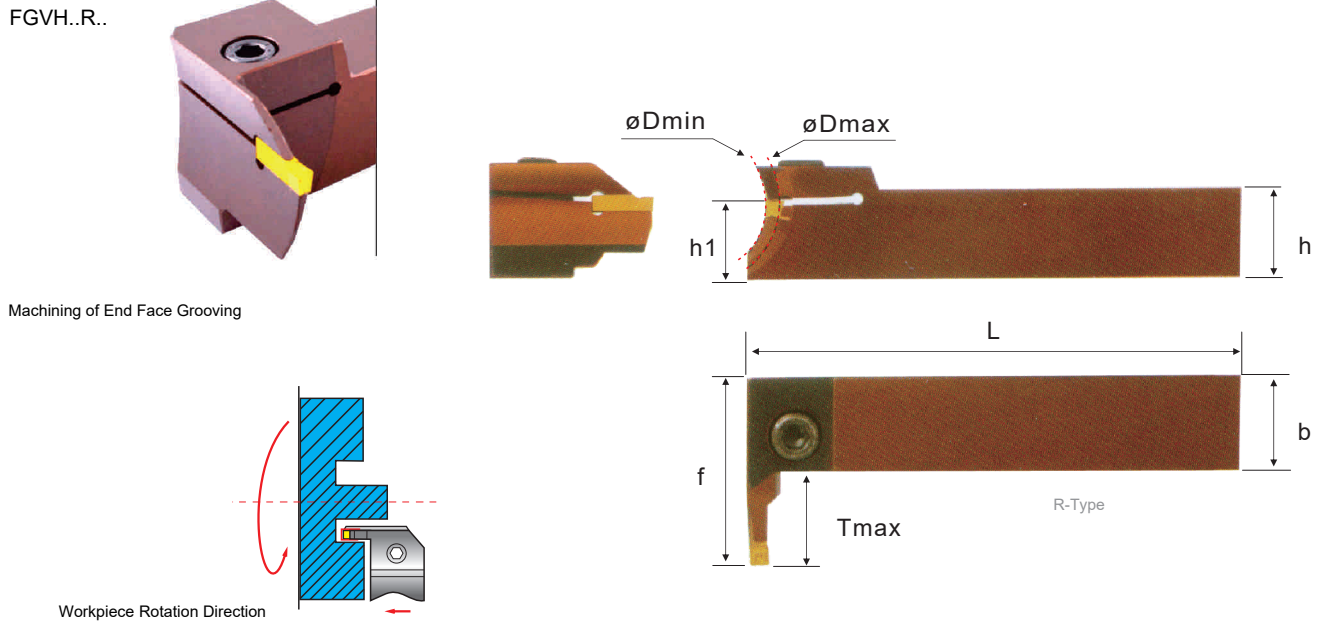

Ordering code	Dimensions							Insert	Screw	Wrench	Stock		
	øDmin	øDmax	f	b=h1	h	L	Tmax				R	L	
FGHH320R/L-	25/30	25	30	20.6	20	20	125	12	FMM300R-03	230103	230062	•	•
	30/35	30	35	20.6	20	20	125	12				•	•
	35/48	35	48	20.6	20	20	125	12				•	•
	48/60	48	60	20.6	20	20	125	22	FGD300R-03 FGM300R-03	230103	230062	•	•
	60/75	60	75	20.6	20	20	125	22				•	•
	75/100	75	100	20.6	20	20	125	22				•	•
100/140	100	140	20.6	20	20	125	22	•	•	•	•		
FGHH325R/L-	25/30	25	30	25.6	25	25	150	12	FMM300R-03	230103	230062	•	•
	30/35	30	35	25.6	25	25	150	12				•	•
	35/48	35	48	25.6	25	25	150	12				•	•
	48/60	48	60	25.6	25	25	150	22	FGD300R-03 FGM300R-03	230103	230062	•	•
	60/75	60	75	25.6	25	25	150	22				•	•
	75/100	75	100	25.6	25	25	150	22				•	•
100/140	100	140	25.6	25	25	150	22	•	•	•	•		
FGHH420R/L-	25/30	25	30	20.6	20	20	125	12	FMM400R-04	230103	230062	•	•
	30/35	30	35	20.6	20	20	125	12				•	•
	35/48	35	48	20.6	20	20	125	12				•	•
	48/60	48	60	20.6	20	20	125	25	FGD400R-04 FGM400R-04	230103	230062	•	•
	60/75	60	75	20.6	20	20	125	25				•	•
	75/100	75	100	20.6	20	20	125	25				•	•
100/140	100	140	20.6	20	20	125	25	•	•	•	•		
FGHH425R/L-	25/30	25	30	25.6	25	25	150	12	FMM400R-04	230103	230062	•	•
	30/35	30	35	25.6	25	25	150	12				•	•
	35/48	35	48	25.6	25	25	150	12				•	•
	48/60	48	60	25.6	25	25	150	25	FGD400R-04 FGM400R-04	230103	230062	•	•
	60/75	60	75	25.6	25	25	150	25				•	•
	75/100	75	100	25.6	25	25	150	25				•	•
100/140	100	140	25.6	25	25	150	25	•	•	•	•		
FGHH520R/L-	25/30	25	30	20.6	20	20	125	12	FMM500R-04	230103	230062	•	•
	30/35	30	35	20.6	20	20	125	12				•	•
	35/40	35	40	20.6	20	20	125	20				•	•
	40/48	40	48	20.6	20	20	125	20	•	•			
	48/60	48	60	20.6	20	20	125	25	FGD500R-04 FGM500R-04	230103	230062	•	•
	60/75	60	75	20.6	20	20	125	25				•	•
75/100	75	100	20.6	20	20	125	25	•				•	
100/140	100	140	20.6	20	20	125	25	•	•	•	•		
FGHH525R/L-	25/30	25	30	25.6	25	25	150	12	FMM500R-04	230103	230062	•	•
	30/35	30	35	25.6	25	25	150	12				•	•
	35/40	35	40	25.6	25	25	150	20				•	•
	40/48	40	48	25.6	25	25	150	20	•	•			
	48/60	48	60	25.6	25	25	150	25	FGD500R-04 FGM500R-04	230103	230062	•	•
	60/75	60	75	25.6	25	25	150	25				•	•
75/100	75	100	25.6	25	25	150	25	•				•	
100/140	100	140	25.6	25	25	150	25	•	•	•	•		

Ordering code	Dimensions							Insert	Screw	Wrench	Stock		
	øDmin	øDmax	f	b=h1	h	L	Tmax				R	L	
FGVH320R/L-	25/30	25	30	36.5	20	20	125	12	FMM300R-03	230103	230062	•	•
	30/35	30	35	36.5	20	20	125	12				•	•
	35/48	35	48	36.5	20	20	125	12				•	•
	48/60	48	60	46.5	20	20	125	22	FGD300R-03 FGM300R-03	230103	230062	•	•
	60/75	60	75	46.5	20	20	125	22				•	•
	75/100	75	100	46.5	20	20	125	22				•	•
100/140	100	140	46.5	20	20	125	22	•	•	•	•		
FGVH325R/L-	25/30	25	30	41	25	25	150	12	FMM300R-03	230103	230062	•	•
	30/35	30	35	41	25	25	150	12				•	•
	35/48	35	48	41	25	25	150	12				•	•
	48/60	48	60	51	25	25	150	22	FGD300R-03 FGM300R-03	230103	230062	•	•
	60/75	60	75	51	25	25	150	22				•	•
	75/100	75	100	51	25	25	150	22				•	•
100/140	100	140	51	25	25	150	22	•	•	•	•		
FGVH420R/L-	25/30	25	30	36.5	20	20	125	12	FMM400R-04	230103	230062	•	•
	30/35	30	35	36.5	20	20	125	12				•	•
	35/48	35	48	36.5	20	20	125	12				•	•
	48/60	48	60	46.5	20	20	125	25	FGD400R-04 FGM400R-04	230103	230062	•	•
	60/75	60	75	46.5	20	20	125	25				•	•
	75/100	75	100	46.5	20	20	125	25				•	•
100/140	100	140	46.5	20	20	125	25	•	•	•	•		
FGVH425R/L-	25/30	25	30	41	25	25	150	12	FMM400R-04	230103	230062	•	•
	30/35	30	35	41	25	25	150	12				•	•
	35/48	35	48	41	25	25	150	12				•	•
	48/60	48	60	51	25	25	150	25	FGD400R-04 FGM400R-04	230103	230062	•	•
	60/75	60	75	51	25	25	150	25				•	•
	75/100	75	100	51	25	25	150	25				•	•
100/140	100	140	51	25	25	150	25	•	•	•	•		
FGVH520R/L-	25/30	25	30	36.5	20	20	125	12	FMM500R-04	230103	230062	•	•
	30/35	30	35	36.5	20	20	125	12				•	•
	35/40	35	40	44.5	20	20	125	20				•	•
	40/48	40	48	44.5	20	20	125	20	•	•			
	48/60	48	60	49.5	20	20	125	25	FGD500R-04 FGM500R-04	230103	230062	•	•
	60/75	60	75	49.5	20	20	125	25				•	•
75/100	75	100	49.5	20	20	125	25	•				•	
100/140	100	140	49.5	20	20	125	25	•	•	•	•		
FGVH525R/L-	25/30	25	30	41	25	25	150	12	FMM500R-04	230103	230062	•	•
	30/35	30	35	41	25	25	150	12				•	•
	35/40	35	40	49	25	25	150	20				•	•
	40/48	40	48	49	25	25	150	20	•	•			
	48/60	48	60	54	25	25	150	25	FGD500R-04 FGM500R-04	230103	230062	•	•
	60/75	60	75	54	25	25	150	25				•	•
75/100	75	100	54	25	25	150	25	•				•	
100/140	100	140	54	25	25	150	25	•	•	•	•		

MFMN

Cutting Environment		Stable Cutting	General Cutting	Unstable Cutting
P	Steel	●	●	●
M	Stainless Steel	●	●	●
K	Iron	●	●	●
N	Aluminum/Copper/Magnesium/Zinc/Plastic/Wood	●	●	●
S	Carbide/Powder Metallurgy	●	●	●
H	Titanium/Superalloy/Carbon Fiber	●	●	●

Dimensioning	Product Image	Specification	Dimension							PCD1	CBN1	CBN2	M100	M140	P130	PMS40	PMS30
			W	r _c	L	B	H	φ									
		MFMN 300	3.0	0.2	18.0	2.0	3.0	-									

End Face Grooving Tool

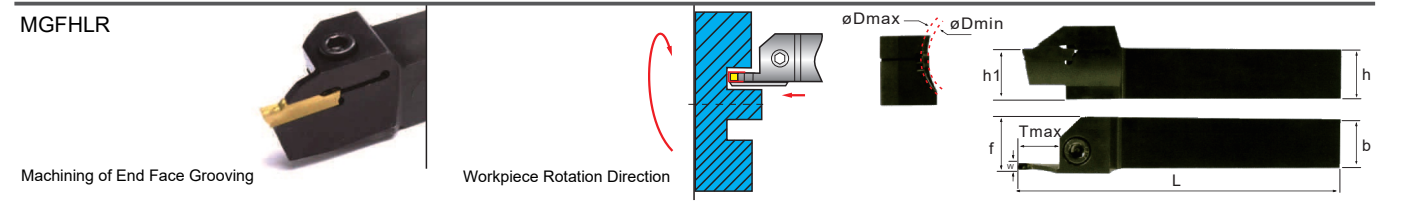

Ordering code	Dimensions							Insert	Screw	Wrench	Stock						
	øDmin	øDmax	f	b=h1	h	L	Tmax				R	L					
MGFHLR 320-	24/35-T10	24	35	20.6	20	20	125	10	MFMN300..	230107	230062	●	●				
	29/40-T10	29	40	20.6	20	20	125	10				●	●				
	34/50-T10	34	50	20.6	20	20	125	10				●	●				
	44/70-T10	44	70	20.6	20	20	125	10				●	●				
	64/69-T10	64	99	20.6	20	20	125	10				●	●				
	325-	24/35-T10	24	35	25.6	25	25	150				10	●	●			
		29/40-T10	29	40	25.6	25	25	150				10	●	●			
		34/50-T10	34	50	25.6	25	25	150				10	●	●			
		44/70-T10	44	70	25.6	25	25	150				10	●	●			
		64/69-T10	64	99	25.6	25	25	150				10	●	●			
		MGFHLR 420-	62/120-T15	62	120	20.6	20	20				125	15	MGMN400..	230107	230062	●
	112/200-T15		112	200	20.6	20	20	125				15	●				●
425-	62/120-T15		62	120	25.6	25	25	150	15	●	●						
112/200-T15	112		200	25.6	25	25	150	15	●	●							

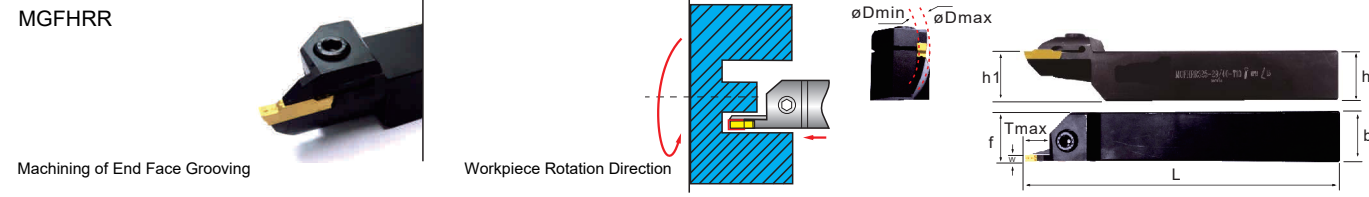

Ordering code	Dimensions							Insert	Screw	Wrench	Stock						
	øDmin	øDmax	f	b=h1	h	L	Tmax				R	L					
MGFHRR 320-	24/35-T10	24	35	20.6	20	20	125	10	MFMN300..	230107	230062	●	●				
	29/40-T10	29	40	20.6	20	20	125	10				●	●				
	34/50-T10	34	50	20.6	20	20	125	10				●	●				
	44/70-T10	44	70	20.6	20	20	125	10				●	●				
	64/69-T10	64	99	20.6	20	20	125	10				●	●				
	325-	24/35-T10	24	35	25.6	25	25	150				10	●	●			
		29/40-T10	29	40	25.6	25	25	150				10	●	●			
		34/50-T10	34	50	25.6	25	25	150				10	●	●			
		44/70-T10	44	70	25.6	25	25	150				10	●	●			
		64/69-T10	64	99	25.6	25	25	150				10	●	●			
		MGFHRR 420-	62/120-T15	62	120	20.6	20	20				125	15	MGMN400..	230107	230062	●
	112/200-T15		112	200	20.6	20	20	125				15	●				●
425-	62/120-T15		62	120	25.6	25	25	150	15	●	●						
112/200-T15	112		200	25.6	25	25	150	15	●	●							

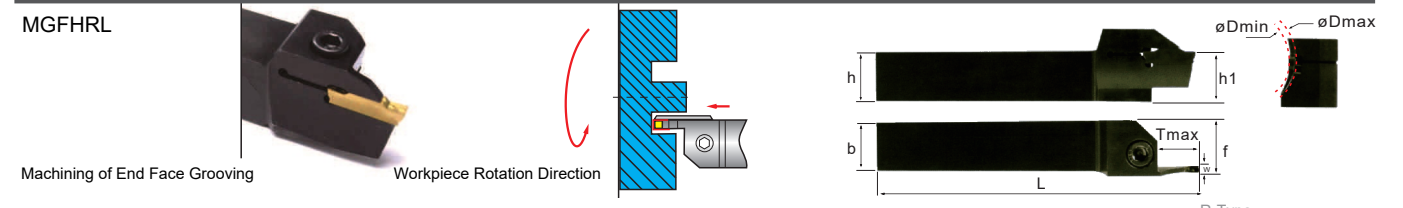

Ordering code	Dimensions							Insert	Screw	Wrench	Stock						
	øDmin	øDmax	f	b=h1	h	L	Tmax				R	L					
MGFHRL 320-	24/35-T10	24	35	20.6	20	20	125	10	MFMN300..	230107	230062	●	●				
	29/40-T10	29	40	20.6	20	20	125	10				●	●				
	34/50-T10	34	50	20.6	20	20	125	10				●	●				
	44/70-T10	44	70	20.6	20	20	125	10				●	●				
	64/69-T10	64	99	20.6	20	20	125	10				●	●				
	325-	24/35-T10	24	35	25.6	25	25	150				10	●	●			
		29/40-T10	29	40	25.6	25	25	150				10	●	●			
		34/50-T10	34	50	25.6	25	25	150				10	●	●			
		44/70-T10	44	70	25.6	25	25	150				10	●	●			
		64/69-T10	64	99	25.6	25	25	150				10	●	●			
		MGFHRL 420-	62/120-T15	62	120	20.6	20	20				125	15	MGMN400..	230107	230062	●
	112/200-T15		112	200	20.6	20	20	125				15	●				●
425-	62/120-T15		62	120	25.6	25	25	150	15	●	●						
112/200-T15	112		200	25.6	25	25	150	15	●	●							

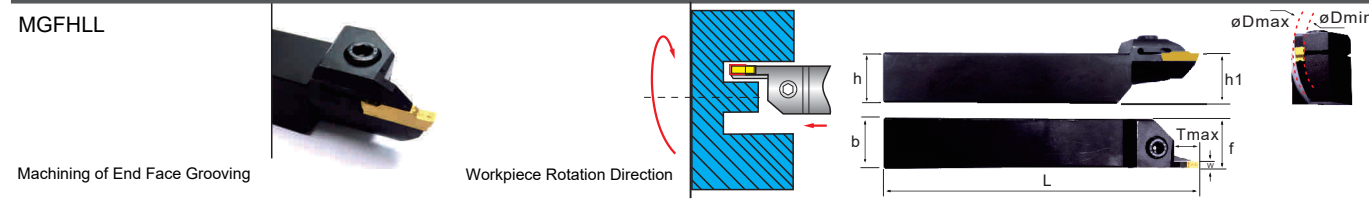

Ordering code	Dimensions							Insert	Screw	Wrench	Stock						
	øDmin	øDmax	f	b=h1	h	L	Tmax				R	L					
MGFHLL 320-	24/35-T10	24	35	20.6	20	20	125	10	MFMN300..	230107	230062	●	●				
	29/40-T10	29	40	20.6	20	20	125	10				●	●				
	34/50-T10	34	50	20.6	20	20	125	10				●	●				
	44/70-T10	44	70	20.6	20	20	125	10				●	●				
	64/69-T10	64	99	20.6	20	20	125	10				●	●				
	325-	24/35-T10	24	35	25.6	25	25	150				10	●	●			
		29/40-T10	29	40	25.6	25	25	150				10	●	●			
		34/50-T10	34	50	25.6	25	25	150				10	●	●			
		44/70-T10	44	70	25.6	25	25	150				10	●	●			
		64/69-T10	64	99	25.6	25	25	150				10	●	●			
		MGFHLL 420-	62/120-T15	62	120	20.6	20	20				125	15	MGMN400..	230107	230062	●
	112/200-T15		112	200	20.6	20	20	125				15	●				●
425-	62/120-T15		62	120	25.6	25	25	150	15	●	●						
112/200-T15	112		200	25.6	25	25	150	15	●	●							

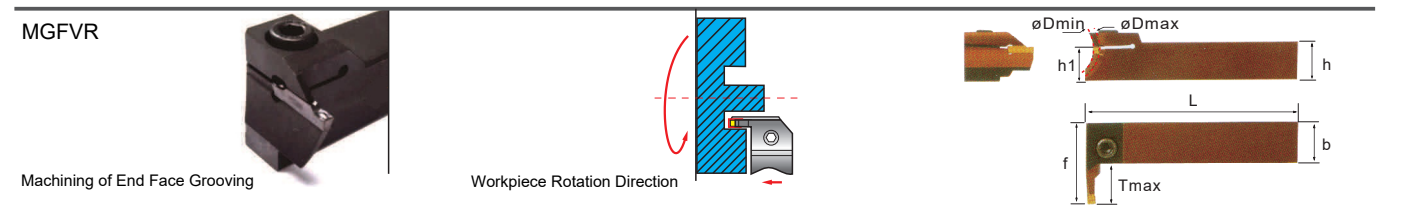

Ordering code	Dimensions							Insert	Screw	Wrench	Stock						
	øDmin	øDmax	f	b=h1	h	L	Tmax				R	L					
MGFVRL 320-	24/35-T10	24	35	31.6	20	20	125	10	MFMN300..	230107	230062	●	●				
	29/40-T10	29	40	31.6	20	20	125	10				●	●				
	34/50-T10	34	50	31.6	20	20	125	10				●	●				
	44/70-T10	44	70	31.6	20	20	125	10				●	●				
	64/69-T10	64	99	31.6	20	20	125	10				●	●				
	325-	24/35-T10	24	35	36.6	25	25	150				10	●	●			
		29/40-T10	29	40	36.6	25	25	150				10	●	●			
		34/50-T10	34	50	36.6	25	25	150				10	●	●			
		44/70-T10	44	70	36.6	25	25	150				10	●	●			
		64/69-T10	64	99	36.6	25	25	150				10	●	●			
		MGFVRL 420-	44/60-T15	44	60	36.6	20	20				125	15	MGMN400..	230107	230062	●
	62/120-T15		62	120	36.6	20	20	125				15	●				●
112/200-T15	112		200	36.6	20	20	125	15	●	●							
425-	44/60-T15		44	60	41.6	25	25	150	15	●	●						
62/120-T15	62		120	41.6	25	25	150	15	●	●							
112/200-T15	112		200	41.6	25	25	150	15	●	●							

